



Vermont Electric School and Transit Bus Pilot Program Report

**Prepared for the
Vermont Department of Environmental Conservation**

June 23, 2023

[Table of Contents](#)

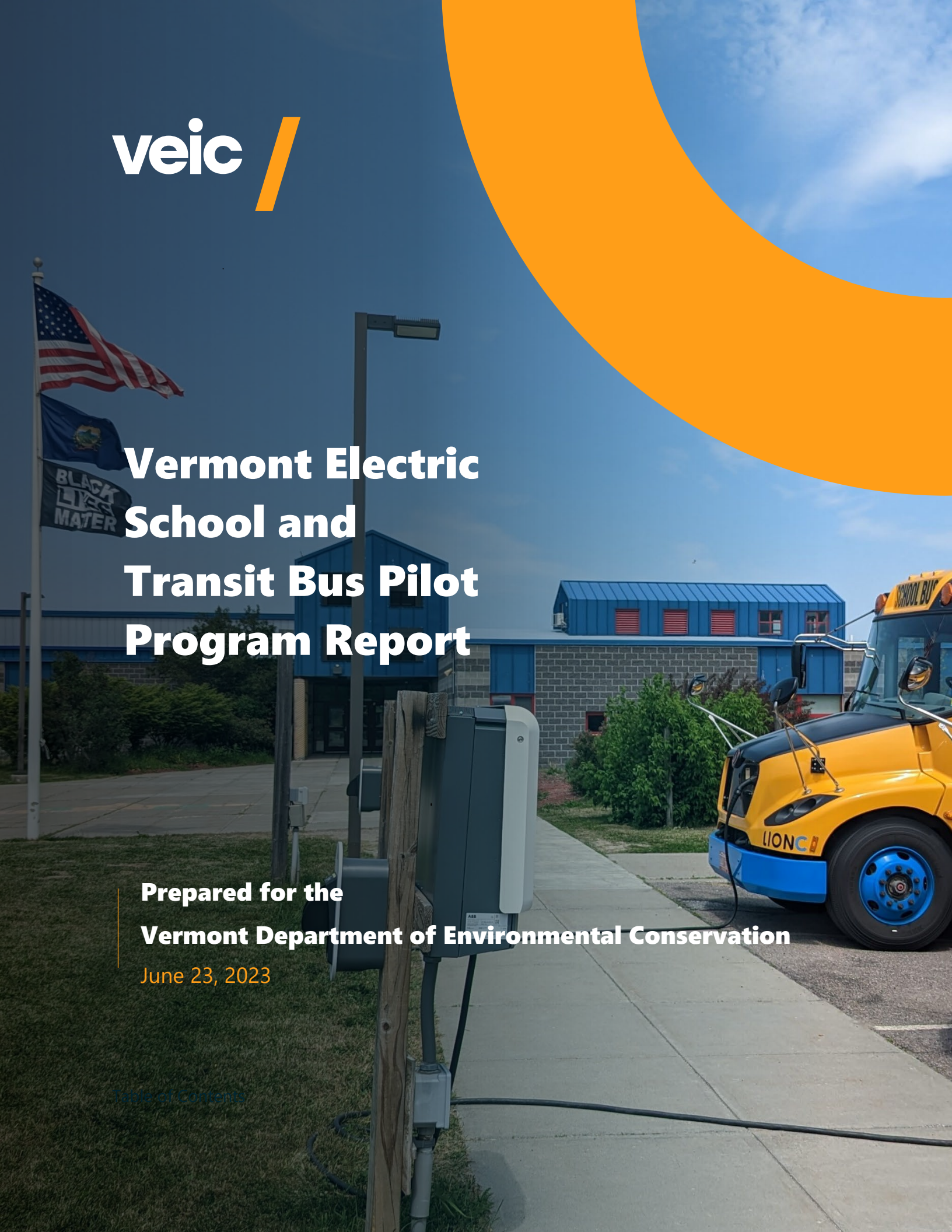

Vermont Electric School and Transit Bus Pilot Program Report	1
Acknowledgements	3
Executive Summary	4
Project Overview	8
Project Overview.....	9
Volkswagen Settlement.....	9
Vermont Beneficiary Mitigation Plan	9
Electric School and Transit Bus Pilot Program	10
Project Activities.....	12
Project Activities	13
Partner Selection Process and Agreements	13
Project Partner Descriptions.....	16
Vehicle and Charging Equipment Procurement.....	17
Electric Vehicle Supply Equipment Installation and Facility Upgrades	22
Scrappage.....	24
Vendor Engagement and Performance Troubleshooting.....	25
Partnerships	26
Project Timeline.....	27
Evaluation	29
Evaluation.....	30
Goals.....	30
Data Collection Methodology	30
Summary of Electric School Bus Findings	33
Summary of Electric Transit Bus Findings	63
Appendices.....	74

Acknowledgements

Report Authors: Kate Cahalane, Project Manager; Tom Fisher, Consultant; Jennifer Wallace-Brodeur, Director, Consulting

Green Mountain Power: Emily Eckert, Dan Mackey, and many others

Project partners:

- **Barre Unified Union School District:** Jamie Evans, Lisa Perreault
- **Student Transport of America:** Stacy Emerson, Brian Hemenway
- **Champlain Valley School District:** Jeanne Jensen, Barry Russell, Lyall Smith, Pat Ward
- **Franklin West Supervisory Union School District:** Justin Brown, Karen Hathaway, Patsy Parker, Grady Plante
- **Marble Valley Regional Transit District:** Jennifer Misencik, Ken Putnam
- The many drivers and maintenance staff who made this project possible!

VEIC: Tom McCarran, Stephanie Morse

Vermont Agency of Transportation: Dan Currier, Barbara Donovan, Ross MacDonald

Vermont Department of Environmental Conservation: Leigh Martin, Megan O'Toole, Deirdra Ritzer, Collin Smythe

Vermont Department of Public Service: Dan Potter

Vermont Energy Education Program: Cara Robecheck, Laura MacLachlan

Vermont Superintendents Association: Jeff Francis

Cover Page Photo Credit: Tom Fisher, VEIC

Executive Summary

When the State of Vermont received Volkswagen (VW) Settlement funds, the Department of Environmental Conservation (DEC) within the Agency of Natural Resources—the lead agency authorized to act on behalf of the beneficiary—allocated a portion of those funds to administer the Vermont Electric School and Transit Bus Pilot Program. The DEC implemented this pilot program to:

- **Evaluate the feasibility of electric buses and electric vehicle supply equipment (EVSE)** operating under conditions comparable to conventional diesel-powered buses (i.e., year-round under a full range of route conditions and settings, such as rural and urban routes or commuter and circulator/shuttle routes).
- **Prioritize project partners** utilizing additional leveraged funding to maximize cost effectiveness of available Environmental Mitigation Trust (EMT) funds.
- **Maximize air quality benefits** by considering the model years of replaced buses, vehicle miles traveled, early attrition¹, areas disproportionately impacted by air contaminants, and other relevant considerations.
- **Familiarize as many Vermonters** from different communities, demographic profiles, and geographic regions as possible within program constraints with electric bus technologies.

Through a competitive process, DEC selected VEIC to administer the pilot. VEIC led selection of project partners, provided guidance and technical assistance to project partners through procurement and deployment of electric buses, and collected and analyzed vehicle performance data. This report summarizes project activities and identifies best practices for project implementation. The report also shares findings from the evaluation of six electric school buses operated by three school districts—Barre Unified Union School District (BUUSD) in partnership with Student Transportation of America (STA), Franklin West Supervisory Union (FWSU), and Champlain Valley School District (CVSD)—and two electric transit buses operated by the Marble Valley Regional Transit District (MVRTD).

The pilot program produced the following key findings:

It is feasible to operate electric school and transit buses in Vermont even in cold weather and varied terrain. The success of that implementation, particularly in winter, may vary between bus manufacturers. Some brands performed well in winter, and some failed to perform at all. Among the buses that were in-service in the winter, some buses performed better than others. Charging equipment performance remained a persistent issue for all sites year-round. However, as Tables 1 and 2 show, most electric buses performed well on daily routes with more than enough battery range, even in cold weather. All project partners realized fuel cost savings and greater efficiency over

¹ Early Attrition: Bus replacements that would have occurred through normal attrition are considered to be the result of normal fleet turnover. Normal attrition is generally defined as a replacement that is scheduled to take place within 3 years of the project start date. Normal attrition is typically defined by the vehicle or fleet owner's budget plan, operating plan, standard procedures, or retirement schedule. Early attrition would be a replacement that is incentivized to occur more than 3 years before it otherwise would have.

their diesel counterparts. In-service days showed the greatest variability. One bus had a perfect service record while others were out for significant periods for service.

Table 1: Electric School Bus Performance Results²

	In-service rate [%]	Average daily trip total [mi]	Average real-world range between charges [mi]	Average efficiency - MPG diesel equivalent [MPGe] ***	First year fuel savings [\$]
BUUSD/STA - Lion Bus 8019	60%	37	74	16	\$548
BUUSD/STA - Lion Bus 8058	86%	32	78	17	\$1,117
CVSD - Lion Bus 8020	73%	75	101**	20	\$2,114
CVSD - Lion Bus 8056	100%	51	94	19	\$2,228
FWSU - Blue Bird Bus 1981*	57%	49	77	14	\$698
FWSU - Blue Bird Bus 1982*	29%	44	89	14	\$531

Table 2: Electric Transit Performance Results

	In-service rate [%]	Average daily trip total [mi]	Average real-world range between charges [mi]	Average efficiency - MPG diesel equivalent [MPGe]***	First year fuel savings [\$]
MVRTD - Gillig Bus 3555	59%	74	160	15	\$8,261
MVRTD - Gillig Bus 3556	89%	82	159	15	\$14,921

Due to the relatively poor fuel economy of diesel transit buses (~4 MPG) and their higher mileage, transit electrification delivered greater savings than school bus electrification.

While electric transit buses are considerably more expensive than electric school buses, the first-year savings of the worst performing transit bus saved more in diesel fuel costs than all six school buses combined. Likewise, the same least performing transit bus reduced roughly as much greenhouse gas emissions as the top three school buses combined.

² *FWSU's Blue Bird range and efficiency values are likely lower than shown here. The buses had very few cold-weather data points, as they were mostly out of service during the months of January, February, and March.

**CVSD Bus 8020 received a battery upgrade 7 months into deployment. Prior to the upgrade the real-world range was 81 miles, and after it was 132 miles. However, much of the first value's drive time included winter driving, while the latter did not.

*** According to the Argonne National Lab, typical Type C diesel school buses have a national average fuel economy of 8.2 MPG. Diesel transit buses average 4.4 MPG.

Cost-share was not a barrier to applicants or selected project partners, but school districts and transit agencies need funding to afford the upfront cost of e-buses. All project partners provided cost-share which allowed VW Settlement funds to be leveraged and to maximize oxides of nitrogen (NOx) emissions reduction and impact. Each school district provided cost-share equivalent to the cost of what their district would spend on two new diesel buses and were able to include this cost share in their budget and have it approved by the school board ahead of making purchases. VW Settlement funds covered the incremental cost of electric buses and the full costs of chargers and installation. MVRTD and the Vermont Agency of Transportation (VTrans) provided cost-share as a percentage of total project costs. Through its Tier III program, Green Mountain Power provided funding to each project partner which reduced the total amount requested from the VW Environmental Mitigation Trust. Without the funding sources available to help offset the cost of the project for each partner, buying electric buses outright would have been cost prohibitive. There are multiple federal, state and utility programs that can support the purchase of electric buses including the VW Settlement, Vermont’s Tier III program, federal and state Diesel Emission Reduction Act programs, the Environmental Protection Agency’s Clean School Bus Program, and the Federal Transit Administration’s Low and No Emissions Vehicle Program.

The project resulted in reductions in NOx and particulate matter that contribute to air pollution and are shown to have negative impacts on human health. Tables 3 and 4 below show these results. By adopting electric buses, school districts and transit agencies can reduce exposure to these harmful emissions among their employees, riders, and communities they serve. Electric buses also lowered greenhouse gas emissions significantly, demonstrating that bus electrification can be a strategy to help meet state climate goals.

Table 3: First Year Environmental Results for Electric School Buses

	NOx reductions vs. scrapped bus [lbs]	PM2.5 reductions vs. scrapped bus [lbs]	PM10 reductions vs. scrapped bus [lbs]	GHG reductions vs. scrapped bus [short ton]
BUUSD/STA - Lion Bus 8019	31.7	0.1	7.9	3.3
BUUSD/STA - Lion Bus 8058	43.2	0.2	10.8	4.9
CVSD - Lion Bus 8020	153.5	9.9	11.0	11.3
CVSD - Lion Bus 8056	154.2	9.9	11.0	11.5
FWSU - Blue Bird Bus 1981	103.5	6.7	7.4	6.6
FWSU - Blue Bird Bus 1982	52.8	3.4	3.8	3.8

Table 4: First Year Environmental Results for Electric Transit Buses

	NO_x reductions vs. scrapped bus [lbs]	PM_{2.5} reductions vs. scrapped bus [lbs]	PM₁₀ reductions vs. scrapped bus [lbs]	GHG reductions vs. scrapped bus [short ton]
MVRTD - Gillig Bus 3555	127.5	0.5	0.6	25.6
MVRTD - Gillig Bus 3556	214.0	0.9	1.0	45.3

Interest in the pilot program spanned diverse regions of the state and produced a diverse applicant pool from urban, suburban, and rural areas. However, electrification readiness differed between school districts and transit agencies. Each project partner benefited from expert technical assistance and supplemental capacity offered by the pilot program, but with fleet management as a core competency and on-site maintenance staff, MVRTD had greater capacity to support electrification.



Photo Credit: VEIC

Project Overview

- **Volkswagen Settlement**
- **Vermont Beneficiary Mitigation Plan**
- **Electric School and Transit Bus Pilot Program**

Project Overview

Volkswagen Settlement

By using devices to defeat emissions controls, Volkswagen violated the Clean Air Act and increased NOx emissions from their light-duty 2.0- and 3.0-liter diesel engines of up to 40 times the standard established by the U.S. Environmental Protection Agency (EPA). As a result, VW entered into settlement agreements with the EPA which awarded \$2.9 billion to an Environmental Mitigation Trust (EMT). Of these funds, \$18.7 million were allocated to the State of Vermont. According to EMT conditions, projects eligible for funding included replacement of diesel vehicles and/or engines in the following categories:

- On-road heavy-duty vehicles such as trucks and buses
- Marine vessels and locomotives
- Non-road equipment such as forklifts and airport ground support equipment

Additional eligible activity included procurement and installation of electric recharging and/or hydrogen refueling infrastructure for light-duty zero-emission vehicles.

Vermont Beneficiary Mitigation Plan

While the State of Vermont is a beneficiary of the Volkswagen Environmental Mitigation Trust, the Agency of Natural Resources serves as the lead agency authorized to act on its behalf. Within the Agency of Natural Resources, the Vermont Department of Environmental Conservation (DEC) administers the state's allocation of funds from the Volkswagen Environmental Mitigation Trust.

DEC developed a Beneficiary Mitigation Plan (BMP) to articulate how it intends to meet the primary objectives of the VW Settlement by mitigating the impacts of excess NOx emissions in Vermont and provide benefits to those populations disproportionately affected by excess NOx emissions. The goals of the Vermont BMP are to:

- Reduce NOx emissions from mobile sources, eligible for replacement or repower, in the most cost-effective way possible
- Demonstrate the feasibility of all-electric or other NOx-mitigating, alternatively-fueled heavy-duty and transit vehicles and begin to catalyze market transformation
- Maximize public and private investment in electric vehicle charging infrastructure

Through engagement with the Vermont legislature and other stakeholders, the DEC determined that Vermont settlement fund allocations would go exclusively to projects that support electric vehicle (EV) adoption or will replace diesel-powered vehicles with EVs. Figure 1 shows planned VW Settlement allocations by sector.

Figure 1: Estimated Vermont VW Settlement Allocations

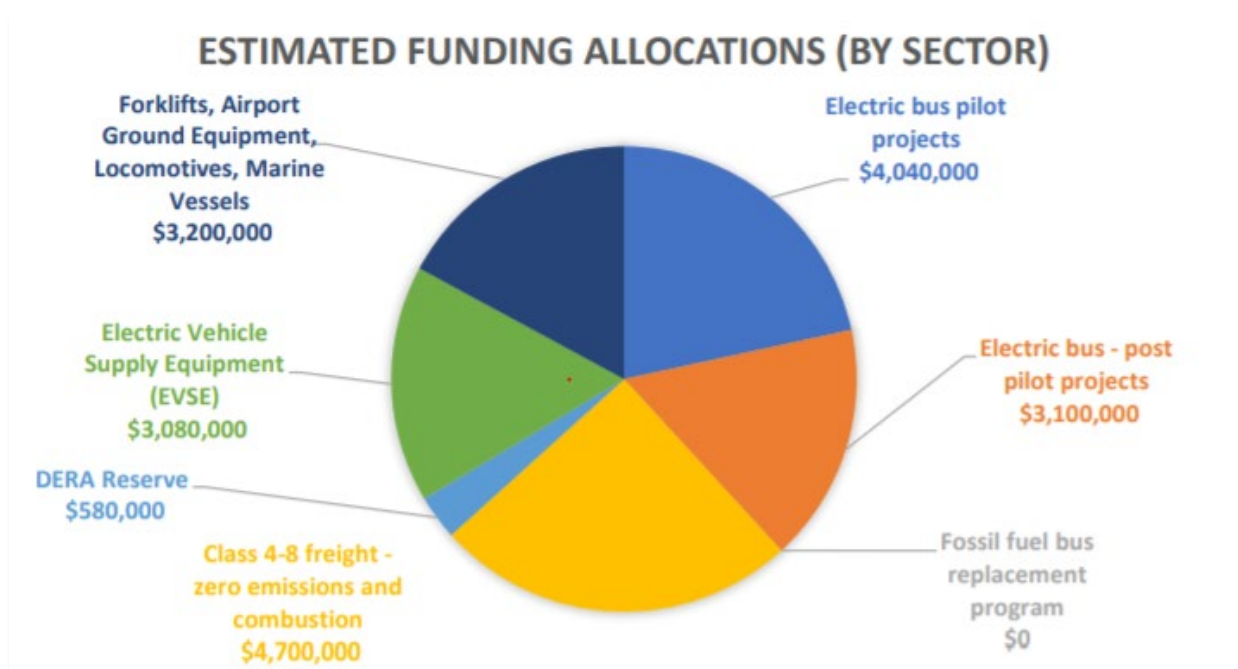

Electric School and Transit Bus Pilot Program

To better understand the feasibility and cost-effectiveness of electric bus operation in Vermont and the potential to reduce NOx emissions, DEC allocated VW Settlement funds to support an Electric School and Transit Bus Pilot Program. The pilot aimed to engage partners across the state and maximize the use of available EMT funds. DEC established the following pilot program goals:

- **Evaluate feasibility of electric buses and electric vehicle supply equipment (EVSE)** operating under conditions comparable to conventional diesel-powered buses (i.e., year-round under a full range of route conditions and settings, such as rural and urban routes or commuter and circulator/shuttle routes).
- **Prioritize project partners** utilizing additional leveraged funding to maximize cost effectiveness of available EMT funds.
- **Maximize air quality benefits** through consideration of model years of buses replaced, vehicle miles traveled, early attrition, areas disproportionately impacted by air contaminants, and other relevant considerations.
- **Familiarize as many Vermonters** from different communities, demographic profiles, and geographic regions as possible within program constraints to electric bus technologies.

On September 28, 2018, DEC released a Request for Proposals (RFP), to select a vendor for the administration and implementation of Vermont's Electric School and Transit Bus Pilot Program and

to facilitate coordination of all parties involved. In December, DEC selected VEIC to design, implement, and administer the program. Work began on June 1, 2019.

VEIC has been a national leader in school bus electrification since 2014, starting with an economic feasibility study of electric school buses in Vermont. The organization administered a pilot project for the Massachusetts Department of Energy Resources, which was the first public pilot of electric school buses in the United States. The evaluation report, published in 2018, continues to be cited and has provided lessons learned to countless school bus fleets. Since 2014, VEIC has provided stakeholder workshops and events to raise awareness of electric school bus technology in 15 states, led demonstration projects to evaluate electric school bus performance and develop lessons learned in four states, provided electric vehicle fleet studies and technical assistance in seven states; and developed national resources for the World Resources Institute's Electric School Bus Initiative to educate school districts on how to conduct facility assessments to determine readiness to host EV chargers, advanced charging strategies, and an introduction to electric school buses.

VEIC partnered with the **Vermont Energy Education Program (VEEP)** to lead engagement with school districts, build awareness of the pilot, and encourage school districts to participate in the program. With an almost 40-year history of collaborating with teachers and students, VEEP is well known around the state for its commitment to scientific rigor and high-quality dynamic pedagogy.



Photo Credit: VEIC

Project Activities

- **Project Partner Selection Process and Agreements**
- **Project Partner Descriptions**
- **Vehicle and Charging Equipment Procurement**
- **EVSE Installation and Facility Upgrades**
- **Scrappage**
- **Vendor Engagement and Performance Troubleshooting**
- **Partnerships**
- **Summary of Project Costs**
- **Project Timeline**

Project Activities

Partner Selection Process and Agreements

VEIC designed and implemented a two-step competitive application process to identify project partners that met all requirements and priorities established in the Volkswagen Environmental Mitigation Trust and in Vermont's Beneficiary Mitigation Plan. The first step in securing project partners was a Request for Qualifications (RFQ) to assess basic eligibility requirements and interest ([Appendix D](#)). The VW EMT and Vermont's BMP established the eligibility requirements which were codified in VEIC and DEC's Contract Specifications of Work. These requirements included:

1. Have diesel-powered, 2009 engine model year (EMY) or older Class 4-8 school buses, shuttle buses, or transit buses that have been and continue to be registered, inspected, and in regular use in Vermont over the last calendar year prior to application submission
2. Demonstrate commitment to scrap applicable diesel-powered buses selected for replacement with electric buses
3. Demonstrate all involved personnel, including management, are supportive of electric bus deployment, as evidenced by letters of support
4. Have adequate fleet/transportation staff or resources for bus operation and maintenance to support deployment of new technology and commit to incorporating necessary protocols to ensure appropriate deployment of managed charging capabilities
5. Demonstrate communication and coordination with applicable electric utility to determine feasibility from an electric infrastructure, supply, and cost perspective
6. Ability and commitment to provide a minimum funding match equal to the cost of a new conventional bus that is comparable to existing buses in their fleet (for schools the expected trade-in value for the replaced bus may be subtracted from their cost share)
7. Commitment to order and purchase the electric bus within twelve (12) months of being selected (extended timeframes may be approved on a case-by-case basis)
8. Commit to fulltime deployment of electric buses and agree that at the end of the pilot program the project partner will continue to use the electric bus and equipment purchased under this assistance agreement in the project or program for which it was acquired as long as needed, whether or not the project or program continues to be supported by grant funds
9. Commit to reporting data as prescribed in the Project Partner Agreement for the length of the project period and continue partial data reporting to the State for as long as the vehicle is in use by the project partner
10. Meet the standards for proof of eligibility

Ten school districts and two transit agencies submitted responses to the RFQ. VEIC and its partner VEEP reviewed all responses and recommended that eight school entities and both transit agencies be invited to respond to a Request for Proposals ([Appendix D](#)) to participate in the pilot.

VEIC developed a score sheet to evaluate the received proposals and convened and facilitated a Selection Committee meeting. The score sheet evaluated the completeness of each application as well as each section of the RFP: existing bus service, infrastructure planning, purchases and matching funds, deployment, and commitment and support.

The selection committee included four representatives from the DEC and one representative from VEIC:

- Jessie Motard-Côté, Planning, Air Quality and Climate Division, DEC
- Megan O’Toole, Office of General Counsel, DEC
- Deirdra Ritzer, Mobile Sources, Air Quality and Climate Division, DEC
- Dave Roberts, Senior Consultant, Transportation Efficiency, VEIC
- Collin Smythe, Planning, Air Quality and Climate Division, DEC

An Advisory Committee including Cara Robeck and Laura MacLachlan from VEEP, Jeff Francis, Executive Director of the Vermont Superintendents Association, Dan Potter of the Vermont Department of Public Service, and Barbara Donovan of the Vermont Agency of Transportation provided additional support for review of submissions.

In addition to the total scores for each application, the selection committee considered the additional factors below:

- Communities disproportionately impacted by air pollution from diesel emissions
- Ability to maximize NOx reductions and air quality benefits
- Geographic diversity
- Opportunity for familiarization of EV technology to Vermonters
- Budget considerations
- Considerations from the site visits
- Input from the Advisory Committee

The Selection Committee recommended that the State select four project partners—three schools and one transit agency—rather than the three originally intended. The State accepted this recommendation, and four applicants were selected as project partners: Barre Unified Union School District with Student Transportation of America, Champlain Valley School District, Franklin West Supervisory Union, and Marble Valley Regional Transit District.

Findings & Best Practices from Project Partner Selection Process



Strong Interest in Electric Buses: Outreach to transit agencies and school districts indicated a strong interest in battery electric buses which was confirmed by the strong response to the RFQ and RFP. The implementation team also found interest among school bus contractors who, in some cases, helped school districts prepare applications for the program. Through direct outreach to school districts, VEEP reported that more school districts expressed interest than ended up applying. In some cases, the availability of buses nearing replacement limited eligibility. To maximize NOx reductions, the EMT requires buses replaced with VW Settlement funds be engine model year 2009 or older. Because Vermont has a relatively high turnover rate for school buses, older fleets are not as prevalent and some interested school districts were unable to participate due to this requirement.



Support Needed to Apply for the Program: Both school districts and transit agencies needed support from VEIC to understand whether their facilities could host electric bus charging, a threshold consideration for any entity seeking to adopt EVs. Available electric capacity along with the configuration of parking lots and garages which house buses can have an impact on project costs and complexity, especially if the facility requires significant upgrades to host chargers. Potential partners also had questions about whether buses could serve existing routes, whether they had eligible vehicles, and program requirements. The two-step application process provided direct assistance and facility evaluation, and helped potential applicants understand the scope and potential cost of their project. This made it easier for potential applicants to decide whether or not to submit a proposal.

Project Partner Descriptions



Barre Unified Union School District / Student Transportation of America

Barre Unified Union School District (BUUSD) applied in partnership with Student Transportation of America (STA) for participation in the pilot. BUUSD serves Barre City Elementary & Middle School (Grades PreK-8), Barre Town Middle & Elementary School (Grades PreK-8), and Spaulding High School/Central Vermont Career Center (Grades 9-12) with a total district enrollment of 2,500. STA was particularly interested in participating in the pilot program to build a solid foundation for future electrification efforts in their large fleet of Vermont vehicles.



Champlain Valley School District

The Champlain Valley School District (CVSD) serves the towns of Charlotte, Hinesburg, Shelburne, St. George, and Williston with a total district enrollment of 3,935. CVSD noted the enthusiastic support from the town of Williston to help meet the state's energy objectives. It planned to test the buses on a variety of routes (varying distances, paved and dirt roads, hills and highway), and utilize them for extracurricular activities and field trips.



Franklin West Supervisory Union

Franklin West Supervisory Union (FWSU) serves the towns of Fairfax, Fletcher, and Georgia. Since the towns of Georgia and Fletcher contract their transportation services to a third-party vendor and FWSU owns the buses operated at Bellows Free Academy in Fairfax, FWSU decided to put their electric buses on the BFA-Fairfax routes which serve approximately 970 students. FWSU included dozens of letters of support from teachers, students, community members, town offices, and school administrators. The community was eager to test out electric buses, enthusiastic about the benefits, and excited to incorporate the learnings from this pilot in the classroom.



Marble Valley Regional Transit District

Marble Valley Regional Transit District (MVRTD) is the public transit provider in Rutland County, serving twenty-seven towns and the city of Rutland. It operates the largest non-urban public transportation system in the State of Vermont and offers more than 745,000 rides annually. MVRTD saw the pilot program as the most viable way for the transit agency to evaluate electric buses in its service territory. MVRTD expressed concern about the poor air quality in Rutland City where it hoped to utilize electric buses on the City Fixed Route. MVRTD also hoped that having electric buses on its routes would improve community perceptions of EVs, noting that EV adoption rates are low in Rutland County compared to the rest of the state.

Vehicle and Charging Equipment Procurement

VEIC supported project partners to select vehicle and charging equipment. The following describes the process used to solicit bids and select vendors.

Request for Proposals

To select the electric bus manufacturers from which the project partners would purchase their buses, VEIC developed four separate RFPs, one for each project partner. VEIC adapted a diesel school bus procurement RFP from CVSD to fit the requirements of each school bus project partner and used a recent electric bus procurement RFP from Green Mountain Transit to define transit bus requirements. VEIC asked bidders to provide details on charging equipment requirements to facilitate the purchase of proprietary or recommended EVSE.

Technology Specifications

Because it is a replacement program, VEIC requested from each partner the specifications from recent diesel bus procurements. These specifications ensured that the new electric buses would resemble in both form and function the vehicles being replaced and also ensured that the base bids provided by the vendors reflected costs that could be covered by the settlement funds. Since CVSD replaced a Type C and a Type D school bus, it required two sets of specifications, one for each bus type. Example specifications provided by each project partner provided a starting point for bus procurement. VEIC's knowledge and experience with electric bus technology made it possible to detail the electric components.

Additionally, each RFP included an options pricing list, which detailed potential add-ons. The options pricing list also provided pricing for items such as extended warranties that were evaluated and discussed with the partners and the State during the review of the proposals. Options pricing ensured that base bids reflected the cost of eligible replacements, with all other items priced separately for consideration.

Given cold Vermont winters, project partners elected to add a diesel-powered auxiliary cabin heater to all buses in the pilot to avoid having to use the vehicle's battery capacity for cabin heat. Although adding a diesel heater will consume some petrochemicals and emit some pollutants during the coldest months, the total annual emissions are considerably less than what a diesel drivetrain would produce.

Evaluation Criteria

All four RFPs included an explanation to the vendors of the evaluation process. The school bus RFPs explained that in selecting the successful bidder, consideration would be given to price, financial responsibility of the bidder, responsiveness to specifications, strength of warranties, proposed delivery date and ability to meet delivery schedule, and the bidder's experience with electric vehicle technology.

Following the practice established in the Green Mountain Transit RFP, the transit bus RFP provided four weighted evaluation criteria: price (30%); ability to meet specifications, delivery dates, and contract documents (25%); reputation of buses proposed (25%); and vendor support, service and parts availability, and length and quality of warranty (20%). For the school and transit bus RFPs, evaluation criteria reflected criteria used in previous school and transit bus procurements.

Issuing RFPs and Proposal Process

Before issuing the RFPs, VEIC coordinated with the DEC to identify and include all appropriate terms from Attachment C: Standard State Provisions, and with MVRTD and VTrans to include all federal contracting requirements and ensure transit purchases qualified for the Federal Transit Administration's contributions to MVRTD's cost share.

VEIC issued the four RFPs on July 2, 2020 ([Appendix F](#)). In addition to posting the RFPs to the Vermont Business Registry and on the DEC's VW EMT webpage, VEIC also coordinated with the State and the project partners to send the RFPs directly to industry contacts.

The RFPs included detailed proposal submission instructions and a procurement schedule. The school bus schedule allowed two weeks for vendors to submit questions in writing; the transit bus schedule allowed four weeks for vendors to submit questions and Approved Equals Requests. At the request of one vendor, the transit schedule was extended to six weeks.

VEIC posted responses to questions on the Vermont Business Registry on a weekly basis. VEIC also supported MVRTD in responding to all Approved Equals Requests.

Proposals Received

The school bus application window closed at 4:00 p.m. on August 6, 2020. Though initially scheduled to close on August 27, 2020, the transit bus application window was extended to September 10, in the same amendment that adjusted the Approved Equals Requests deadline.

In response to all three school bus RFPs, VEIC received electric school bus proposals from ANDCO, Inc. DBA Anderson Blue Bird Sales of New England, The Lion Electric Co. (Lion), and W. C. Cressey and Son, Inc., a privately held Thomas Bus Dealer.

MVRTD received proposals from four electric transit bus vendors: BYD Coach and Bus LLC (BYD), Gillig, LLC, New Flyer of America Inc., and Proterra Inc.

Review Process

Evaluation

To facilitate the proposal review process, VEIC developed evaluation forms for the school bus and transit bus proposals. These evaluation forms provided a space to score each of the criteria identified in the RFPs and comment on strengths and weaknesses related to each criterion. Evaluation forms also included space for any additional comments not directly related to the specific evaluation criteria.

Project partners completed an evaluation form for each proposal received, and VEIC did the same. For the MVRTD proposals, a representative from VTrans also contributed to the review and completed evaluation forms for each proposal. After the project partners, VEIC, and VTrans reviewed each proposal independently, VEIC scheduled meetings with each project partner to discuss our reviews of the proposals. These meetings began with project partners sharing their evaluations of each proposal. VEIC shared additional observations from our review. In the review meeting with MVRTD, the representative from VTrans shared additional observations as well. VEIC carefully documented review meeting notes as well as any follow-up questions the project partners wanted to ask of the vendors.

Selection and Approval

Responses from the vendors to follow-up questions provided each project partner with the information needed to make a selection. VEIC compiled information packets—including all proposals received, completed evaluation forms, meeting notes, and additional information provided by vendors—for the DEC team’s review. Table 5 shows the vendors and equipment selected by each project partner.

Table 5: Selected Vendors and Equipment by project partner

Project partner	Selected bus vendor and type	Selected EVSE vendor and type
FWSU	2021 Blue Bird 77 passenger Type C 120-mile range (2)	Nuvve charging station: Level 2, 16.6 KW (2 units)
CVSD	2021 77-passenger Lion C 100-mile range (1) 2021 77-passenger Lion C 125-mile range (1) ³	ABB Terra Wallbox: DC, 22.5 KW (2 units)
BUUSD/STA	2021 77-passenger Lion C 100-mile range (2)	ABB Terra Wallbox: DC, 24 KW (2 units) (Temporary installation of (2) Delta wall-mounted DC 24 KW chargers which remained in place for the duration of the project due to issues with the ABBs)
MVRTD	Gillig: 35’ Low Floor Plus Battery Electric Buses 150-mile range (2)	ABB Terra 54 Fast Charger: DC, 50 kW (2 units)

³ CVSD initially selected one Type C bus and one Type D bus and scrapped one bus of each type. However, Lion informed the school that the Type D bus would be significantly delayed and offered the use of a second Type C bus until the Type D was ready. Several months into the pilot, CVSD and Lion reached an agreement to allow CVSD to keep this second Type C, but with the addition of an expanded battery pack as compensation for the added cost.

Notification of Awards

VEIC notified school bus vendors on August 27, 2020 of the selection and requested detailed pricing and build sheets for the requested buses. VEIC notified transit bus vendors on October 22, 2020 of the selection and requested a meeting with Gillig to determine the final specifications for the buses. After a series of meetings, Gillig provided a final pricing sheet to MVRTD.

Summary of Project Costs

The pilot required each project partner to provide cost share in order to participate. For schools, the minimum match requirement was equivalent to the cost of a new conventional bus comparable to existing diesel buses in their fleets (less the expected trade in-value for the buses to be replaced). For MVRTD, the match amount was equivalent to 25% of the cost of the electric buses. Table 6 provides a summary of all project costs.

Table 6. Summary of Project Costs

	BUUSD/STA	CVSD	FWSU	MVRTD
Vehicle purchases				
Bus 1	\$336,320	\$352,796	\$340,119	\$838,974
Bus 2	\$336,320	\$360,755	\$340,119	\$838,974
Installation, site work, and sub-meter	\$14,260	\$12,550	\$31,927	\$145,187
Chargers - costs per charge port	\$12,970	\$12,970	\$5,650	\$44,667
Total Project Costs	\$712,840	\$752,041	\$723,465	\$1,912,468

Electric Vehicle Supply Equipment (EVSE)

None of the selected vendors (or any of the bidders who submitted proposals) required proprietary EVSE to charge their buses. However, Lion, Anderson Blue Bird Sales of New England, and Gillig suggested preferred EVSE that could be purchased through them. VEIC and school bus partners determined this to be the best option because bus vendors play a role in the site design, purchase, and installation of EVSE and provide additional assurance that they can help troubleshoot any problems encountered with the buses or the EVSE. VEIC did not recommend that MVRTD purchase its EVSE through Gillig, but instead suggested that it join an upcoming statewide transit bus EVSE procurement. MVRTD, VTrans, and DEC all agreed.





After consideration of site details, Lion and Anderson Blue Bird Sales of New England provided estimates for the purchase of the EVSE deemed most appropriate for each site.

Purchase Orders

VEIC submitted all final bus pricing, build sheets, and EVSE estimates to the DEC team to ensure compliance with EMT eligibility requirements and to approve the release of EMT funds.

- STA executed its purchase order with Lion for the buses on November 9 and for the EVSE on November 24, 2020.
- CVSD executed its purchase order with Lion for the buses on November 16 (dated November 12) and for the EVSE on December 7, 2020.
- Anderson Blue Bird Sales of New England requested a deposit from FWSU for the Blue Bird buses; FWSU finalized its bus purchase order (dated November 9) by paying a deposit of \$150,700 on November 20, 2020 (received November 23). FWSU submitted its EVSE purchase order on December 8, 2020.
- MVRTD executed a purchase order for its buses on December 22, 2020.

Findings & Best Practices from the Vehicle and Equipment Procurement Process

	<p>RFP Development: Development of the electric bus RFPs was much more detail-oriented and time consuming than originally expected. Providing one of the RFPs developed in the pilot as a template to others should save considerable time and effort, though careful review will still be needed.</p>
	<p>Delivery Schedules: Bus manufacturers often take 9-12 months to deliver a bus after receiving an order and expect full payment upon delivery. Even when delivery schedules are promised in contracting documents, these timelines vary by bus manufacturer and are not reliable. VEIC recommends holding off on scrapping buses especially if there is a small or no spare ratio until electric buses arrive and are on the road.</p>
	<p>Stakeholder Coordination: To ensure adherence to federal procurement, it was essential to coordinate with the Transit Division of VTrans throughout the transit vehicle and EVSE procurement process. Utilities were also critical partners to support assessment of facility electrical capacity and coordinate on any needed facility upgrades.</p>
	<p>EVSE Specifications: Even with support from VEIC, it was difficult to evaluate the pros and cons of Level 2 v. DC charging for school buses. They are site specific and complicated, and Vehicle Original Equipment Manufacturers (OEMs) and utility representatives offered varied opinions on the question. Without technical assistance, bus operators may procure EVSE that is higher capacity, and more expensive, than needed to support their electric buses.</p>

Electric Vehicle Supply Equipment Installation and Facility Upgrades



Photo Credit: Tom Fisher, VEIC

VEIC worked with each of the project partners and their electrical staff or contractors, Green Mountain Power and EVSE vendors to identify any facility upgrades needed to host chargers and support EVSE installation. Site work to prepare for the installation of EVSE began soon after the procurement of EVSE. School districts commenced work in December 2020 – January 2021. Work continued until June 2021, when all school site upgrades had been completed. In some instances, frozen ground delayed work but in many cases work continued through the winter months. For BUUSD and FWSU the February school break proved to be an optimal time to focus on site work.

Installation of EVSE at each school site was completed by June 2021. FWSU completed upgrades and installed and commissioned EVSE in March 2021, plenty of time before delivery of their buses. Both CVSD and BUUSD experienced complications with EVSE installation despite these sites being ready to host chargers. At CVSD, delivery delays of their Lion buses affected driver training scheduled for August and school transportation operations. As a result, Lion agreed to provide two demonstration buses to CVSD until delivery of the permanent buses. These buses were not compatible with the DC chargers that had been ordered; therefore, two Clipper Creek AC Level 2 chargers were installed temporarily to charge these demonstration buses. Lion covered all additional expenses. Upon delivery of the permanent buses, the team removed the Clipper Creek chargers and installed the two ABB DC chargers from the original order.

At BUUSD, a concern about delayed chargers prompted the development of alternative solutions with Lion. Due to shipping delays, in May 2021, Lion delivered two temporary Delta chargers. Over the following summer, Lion delivered two ABB chargers intended to be installed in place of the Delta chargers, however the units sent were not configured for the correct voltage service at this site. The project partner exchanged these for the correct units and installed these new ABB chargers in early June 2021. The ABB chargers did not operate as smoothly as expected, and the temporary Delta chargers remained on site and were used to charge one or both the buses for the duration of the pilot (further detail is provided in BUUSD’s Maintenance and Reliability section on [page 47](#)).

Troubleshooting the ABBs continued throughout the rest of the monitoring period. The ABBs were beginning to be fully utilized just as the project was winding down. STA intends to move the ABB chargers to a new depot where the electric school buses will be charged in the long run.

STA installed a separate utility service connection to isolate bus charging from the school’s other electrical usage. This also allowed STA to take advantage of beneficial rates from GMP (Rate 6) which removed concerns about incurring high demand charges. VEIC worked closely with GMP and the project partners to facilitate the necessary upgrades.

After selecting EVSE through a statewide transit procurement, MVRTD completed site work in October 2021. After executing their purchase order for EVSE from their selected vendor, OpConnect, MVRTD learned of a 35-week delivery delay. With MVRTD’s Gillig buses expected in December, VEIC focused on finding a solution. The team learned of two ABB chargers that could be shipped expeditiously from Lion in Quebec City and were compatible with Gillig buses and with the OpConnect software for managed charging. MVRTD purchased and installed these chargers.

Findings and Best Practices from EVSE Installation and Facility Upgrades



EVSE Installation: Even with significant lead time and planning, installation of EVSE was more time consuming than anticipated. Delays in delivery of chargers and coordinating with utility and electrical contractors all contributed to a longer than anticipated installation process.

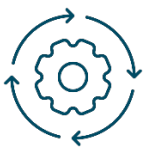

Purchasing EVSE through the vehicle vendor was not simpler and did not provide more reliable delivery timeframes. EVSE may be more of a side-thought for many vehicle OEMs. A company that specializes in EVSE might be more responsive to the need for proper installs and might address maintenance issues more expeditiously.

Scrappage

The pilot program required that participants each 'scrap' the two diesel buses to be replaced by electric buses, within 90 days of the electric buses arriving. The diesel buses had to be engine model year 2009 or older. As a condition of participation, project partners agreed to document the scrappage event at a local, permitted salvage yard, with photos before and after, and submit a 'Vermont Scrappage Form' to DEC. Representatives from VEIC and the DEC attended all four scrappage events. VEIC supported each project partner in contacting a salvage yard to schedule a day to scrap the two diesel buses. VEIC also supported each project partner to provide scrappage documentation required by DEC.



Photo Credit: Tom Fisher, VEIC

Best Practices from Scrappage



Coordination Needed to Meet Requirements and Document Process: Many bus replacement programs require scrappage of replaced vehicles and documentation of the process. It was challenging to communicate the requirements and ensure that salvage yards followed the correct process. Clearly communicated stage gates for what should be done, when, and by whom can aid in achieving the desired outcomes.

Vendor Engagement and Performance Troubleshooting

VEIC remained heavily engaged with vendors throughout the duration of the project. In the early stages of the project, VEIC communicated with bus vendors on a regular basis to confirm delivery timeframes and specifications, and to ensure clear communication about delays. VEIC remained engaged with vendors to troubleshoot performance issues. VEIC met with Lion and Anderson Blue Bird Sales of New England on a weekly basis until all school buses were on the road and operational. VEIC resumed weekly meetings with Anderson Blue Bird Sales of New England in January of 2023.

Findings and Best Practices from Vendor Engagement and Performance Troubleshooting



Bus Delivery: When buses arrive there are multiple issues that are important to consider to make sure buses meet specifications and are ready to be deployed. In every delivery, VEIC found issues that needed to be addressed by the vendor. Therefore, bus manufacturers and the bus operators should be prepared to spend enough time on the day of delivery to support vehicle inspection and a walk-through to ensure the vehicle meets the requested specifications. It is also important to plan ahead to insure and register the buses so they can begin driving as soon as possible. Bus operators should make facility and insurance providers aware of the purchase of electric buses and EVSE before delivery.



Driver Training: Hands-on driver training is critical to driver success and comfort with battery electric buses. The learning curve is not steep, but drivers are often apprehensive about learning the technology. It is sensible to coordinate driver training from the vendor with bus delivery. VEIC also found it helpful to provide time for driving the bus without students. Strong driver training includes 'what if...' scenarios which can mitigate backlash from drivers if they encounter issues they do not understand or situations that can be avoided. For example, it can be difficult to judge how much range is available when the battery is close to its limit. If a driver has this information as part of their training, then running out of battery can be avoided. To ensure a solid and fruitful training, the organizer should request an advanced copy of the agenda and materials to be covered. This will help vendors understand expectations and prepare. It can be easy to rush through training, but time should be given to let the drivers experience odd maneuvers and procedures. It should not be approached as a test-drive, but as a technique to improve safety and reliability, and reduce future frustration.



Maintenance: Throughout the project it was challenging to get timely resolution to maintenance issues. In general, the transit agency was able to address maintenance issues more quickly, because they had a team of trained mechanics and a full shop with vehicle-specific equipment to troubleshoot many issues. School districts that rely on local service centers faced more challenges even when local service centers are certified to work on OEM electric vehicles, a rarity given the onerous process needed to achieve certification. As observed during this pilot, when these centers did not know how to resolve an issue, they were not likely to report the problem. The team found that even local shops certified by OEMs for work on electric buses tend not to be staffed adequately to work in a timely manner on these vehicles. This led to significant delays in service, keeping the buses off the road for longer than necessary. Support from dealers and vendors was inconsistent. Among vendors, Gillig was very responsive while the school bus vendors, particularly Anderson Blue Bird Sales of New England, tended to be slower to address major issues during the pilot.



Adding an additional charger at the service location, if not on site, also proved itself worthwhile. If a vehicle has to be taken out of service for an extended period, or if it comes in for maintenance low on energy, it can be convenient to have a cheaper, low-power charger available to recharge the battery before returning it to service.

Partnerships

Partnerships were essential to the successful delivery of the pilot program. The following organizations were engaged throughout the project.

- **Vermont Energy Education Program (VEEP)** conducted outreach to school districts to inform them about the pilot program, answered questions, and referred interested school districts to VEIC for site visits and technical assistance. VEEP also provided input to the project partner selection process.
- **Vermont Superintendents Association** provided input on pilot program design, engagement of school districts, and participated in the project partner selection process.
- **Green Mountain Power (GMP)** provided support to their customers through site assessments, coordination on facility upgrades, charging strategies and utility rates. GMP also contributed towards cost-share in the form of incentives through its Tier III program.
- **Vermont Agency of Transportation (VTrans):** supported MVRTD with all aspects of program delivery including procurement, facility upgrades, deployment issues, and planning for additional electric bus deployment. VTrans also provided funding to help MVRTD meet the cost share requirements of the program and provided input to VEIC on transit agency outreach and pilot program design.

Project Timeline

DEC and VEIC executed the project contract on May 15, 2019 and work commenced on June 1, 2019. The original contract end date was June 1, 2021, but the timeline was amended twice. The first timeline amendment adjusted the end date to March 31, 2023 in order to align the twelve-month data collection period with bus delivery dates, which were staggered over several months among the project partners. The second timeline amendment adjusted the project end date to June 1, 2023 so that FWSU could track vehicle performance through the winter of 2022-2023 and generate a more robust set of cold weather data. This extension also enabled a full twelve months of data collection from the BUUSD and MVRTD buses, which were delivered and deployed later during the pilot. Figure 2 shows the final project timeline.

Many variables affected the project timeline.

- Contracting with project partners took longer than anticipated due to questions from project partners and review and approval processes among all parties.
- The procurement process was more involved and time consuming than anticipated, particularly for the transit buses which had to meet federal procurement guidelines including review of Approved Equals Requests.
- Vendor delivery schedules for vehicles and chargers were unknown until vendors responded to RFPs with their proposed schedules. Proposed delivery times varied among school bus vendors and delivery schedules shifted once orders were placed. Transit buses took the longest to produce and deliver which was expected since these buses are typically customized, whereas school buses tend to be more standardized.
- Data collection schedules were staggered based on when buses arrived. FWSU and CVSD received their buses in July of 2021 and began data monitoring at the start of September 2021. There was limited data collection in the winter of 2021-2022 at FWSU because buses were out of operation for large parts of the season. VEIC and FWSU extended data collection into 2022-2023 to try to capture more winter data. BUUSD/STA had its buses delivered in November and December of 2021, but data collection at BUUSD/STA did not begin until April of 2022, due to issues with getting the chargers up and running. MVRTD received its transit buses in February of 2022, and spent a full month for thorough review and testing before placing them into regular service. Further delays setting up telematics and energy data monitoring postponed data collection at MVRTD until the start of April 2022.

Figure 2: Timeline of Major Project Activities

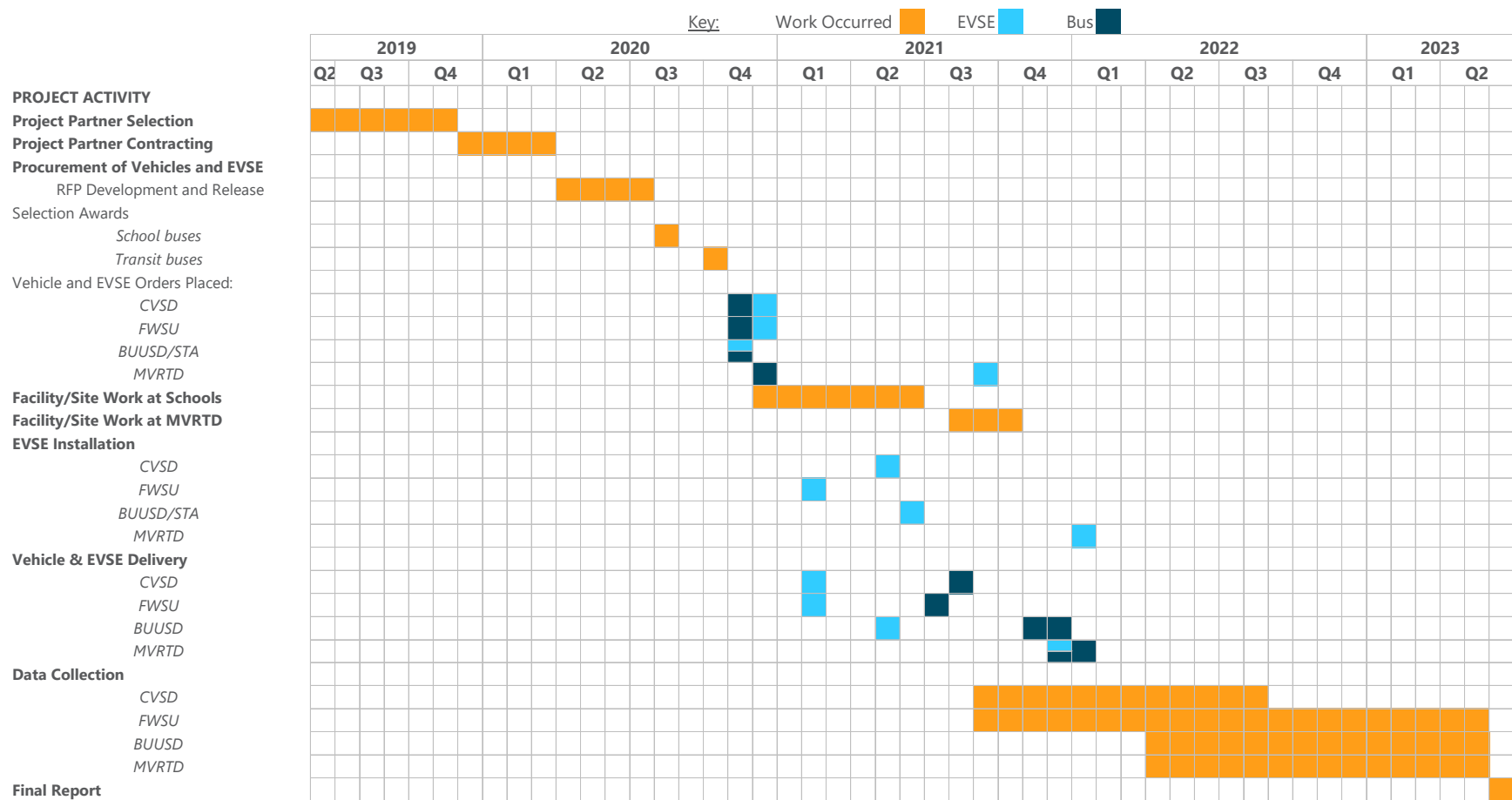



Photo Credit: Tom Fisher, VEIC

Evaluation

- **Goals**
- **Data Collection Methodology**
- **Summary of Electric School Bus Findings**
- **Summary of Electric Transit Bus Findings**

Evaluation

Goals

The pilot established three principle goals: 1) to test the viability of school and transit bus deployments in the state of Vermont, 2) to foster other successful electric bus deployments, and 3) to provide indicators to guide the state's use of the remaining VW Settlement funds.

VEIC evaluated vehicle viability and performance with the following criteria:

- **Performance:** to evaluate the suitability of operation in Vermont. The pilot investigated the effects of cold weather and suitability of buses for rural, multi-town districts in the hilly to mountainous terrain of the Green Mountain State.
- **Emissions:** comparisons were made against two different baselines – 1) the exact bus scrapped and 2) a new diesel bus of similar size and type. The latter also allows for the contrast and comparison between districts.
- **Reliability:** As electric buses are an emerging technology, the project sought to test the reliability of electric buses in rural, cold-weather operating conditions.
- **Cost Savings:** While electric buses still cost considerably more than their diesel counterparts, the pilot aimed to measure what fuel and maintenance cost savings might begin to offset that upfront capital cost increase.

Data Collection Methodology

To achieve the pilot's goals, the team compiled real-world data across many parameters and overlapped data collection techniques to ensure that sufficient information would be captured. This process allowed the data to be cross-checked against other sources and heightened the reliability of the findings.

The team collected at least 12 months of data for each bus and covered all weather and driving conditions. The following automated and manual data sources were collected monthly:

- **Energy consumption** was recorded via both Green Mountain Power's (GMP) Advanced Metering Infrastructure (AMI) as well as through a utility-grade, third-party sub-meter installed at the panels powering the vehicle charging units.
- **Distances traveled and battery state-of-charge (SOC)** were captured using a combination of vehicle telematics (on board parameter and fault logging) as well as via hand-written trip logs submitted by drivers.
- **Driver logs** also allowed for the collection of information on the timing and routes of trips, times of departure and return, maintenance issues, and the amount of diesel consumed by the auxiliary cabin heaters.

- **Maintenance reports and costs** were provided by district maintenance staff and dealer warranty/repairs departments. While similar information was sought on the diesel buses in each fleet for comparison, responses were too limited on details for a fair comparison to be made between these new electric buses and what might be expected on new, similar diesel buses.
- **Ambient weather conditions** were noted in the driver logs. VEIC also compiled detailed hourly weather records from the nearest National Oceanic and Atmospheric Administration (NOAA) weather stations.
- **Electric utility and regional diesel pricing** were collected and applied to the above data sources. Diesel prices were taken from the State of Vermont Agency of Transportation – Fuel Price Adjustment tables published each month⁴. Green Mountain Power is the electric utility for all project partners, and all were on ‘Rate 6’, which charged a simple \$0.17141 per kWh⁵.

To ensure reliability, all data were error-checked, cleaned, and cross-checked against available resources. The team then utilized daily, hourly, and minute-to-minute data to generate a record of daily sums and averages. Once verified, the team used standard calculation techniques, scientific formulas, and environmental scaling factors derived from the Argonne National Lab Alternative Fuel Life-Cycle Environmental and Economic Transportation (AFLEET) Tool⁶ to generate various parameters describing bus performance.

On a monthly basis, the team provided DEC with a summary report of activity and vehicle performance along with considerations, insights, and lessons learned to that point. Given that methodologies evolved over the course of this multi-year study, the team verified the final data presented here and standardized final calculation processes to ensure meaningful comparisons over time.

Data Collection Findings and Best Practices



Data Collection: With multiple data streams and an extended pilot timeframe, it was critically important for the team to consider long-term reliability and accuracy of the various data sources and to ensure consistent automated data correction rather than trying to assess the reliability of each manual data entry. This process included periodic checks against other sources of data such as monthly odometer or fuel use readings and utility bills. It can take time to commission new data

⁴ <https://vtrans.vermont.gov/contract-admin/resources/construction-contracting/fuel-price-adjustment>

⁵ GMP increased their Rate 6 tariff to \$0.18336/kWh in October 2022. However, the initial rate of \$0.17141 was used throughout the project for a cleaner comparison between vehicle expenses over the multi-year period. GMP’s current rates can be found at: <https://greenmountainpower.com/rates/>

⁶ Argonne National Lab Alternative Fuel Life-Cycle Environmental and Economic Transportation (AFLEET) Tool - https://greet.es.anl.gov/afleet_tool

streams at a site and set up reliable data retrieval processes. Future EV performance studies would be well served to build a 2–4-week lead time into their project timelines.



Telematics, AMI, and Sub-meters: Some telematics platforms (such as LionBeat) were reliable sources for both mileage and state of charge (SOC), falling within 2% agreement with data from driver logs. However, telematics do not monitor charger losses and phantom loads (unexpected, usually low-level power draws) and therefore do not reflect total operational energy usage. Sub-meter and AMI data corresponded very well, with a correlation of 99.7%. Sub-meter data can be broken out per charger and at a finer interval and is thus much more useful than relying solely on AMI data. Driver logs should request estimates of rough diesel tank fullness (7/8ths, 1/4th, etc.). Asking only for filled gallons means heater use can only be estimated through monthly or weekly temperature averages. With some periodic odometer verification, bus telematics can be the primary data source for mileage and SOC data over driver logs.



Summary of Electric School Bus Findings

- **Top Findings**
- **Electric School Bus Results**
- **Barre Unified Union School District / Student Transportation of America**
- **Champlain Valley School District**
- **Franklin West Supervisory Union**

Top Findings

Electric school buses can work for Vermont. With all pilot school buses on the road for 1-2 years, the study has demonstrated that electric school buses can work in the Vermont context. It is important to note that the pilot showed variations in reliability among vendors (Tables 1 and 2) and found some limitations on range and performance during the harshest northeast weather conditions. However, even operating under reduced ranges with midday charging, buses had sufficient range and handling to adequately cover at least some of each district's daily routes.

The most significant impact on electric school bus performance is the ambient weather condition – in particular, the temperature. The buses achieved their optimum efficiency at temperatures above 65 degrees Fahrenheit. As temperatures dropped, vehicle range reduced in a relatively linear manner. At zero degrees Fahrenheit, the Lion bus ranges had dropped off by 30-40% of the nominal range advertised by the manufacturer. For Blue Bird buses, the range loss at zero degrees was closer to 80%. The wide span of this temperature impact appears to be due to two factors: thermal management design and distances driven.

Some electric buses appear to be better suited to cold climates than others. While buses from only two OEMs were selected for school bus evaluation in Vermont, the Lion Electric buses performed considerably better in the state's cold climate than the Blue Bird buses. This is evident not only in the temperature effects on the Blue Bird buses—both Blue Bird buses lost as much as half their range before temperatures reached the frost point (32 degrees Fahrenheit)—but also both Blue Bird buses were inoperable for most of the two winters in which they were evaluated.

Continuous thermal management, sometimes provided by auxiliary diesel heat, markedly aided the drivetrain on electric buses. Careful attention to the design and maintenance of thermal management systems materially improves the range reduction factors in temperature extremes as well as reducing considerably the mechanical issues encountered with the vehicles. However, these improvements do come at the expense of burning petrochemicals in a less-well-regulated combustion apparatus, thereby appreciably increasing the emission of criteria air pollutants.⁷

⁷ This study did not evaluate cabin air quality. At this stage of technological development, it is prudent to add an auxiliary diesel heater to reduce the draw off the batteries during cold weather in northern climates. While eliminating drivetrain emissions should reduce air pollutants in and around the vehicle, the auxiliary heaters are less well-regulated than vehicle drivetrains and, without specific data, this report does not attempt to indicate either an improvement or degradation of air quality for riders.

Reducing the percentage of driving that occurs while the vehicle's batteries are at full capacity can significantly improve vehicle efficiency. Driving the vehicles further or not charging up the batteries to full capacity can achieve this result. When the batteries are 'full', there is no capacity to store energy from regenerative braking. Once there is battery capacity to store energy, vehicle efficiency for those first 10-20 miles can be increased by 16-25%⁸.

Compared to scrapped diesel buses and new diesel buses, even the poorest performing electric school bus achieved fuel cost savings and emissions reductions. In the best case, a single electric bus reduced fuel and maintenance costs for by over \$8,000 per year while lowering greenhouse gas emissions by over 11 U.S. tons annually—an amount equivalent to the weight of an empty school bus.

EVSE is a critical component of an electric bus fleet, and significant attention should be paid to the charger selection, placement, operation, and maintenance. Every site in this study experienced charging issues which forced vehicles out of service for periods of time. Though a relatively cheaper component of an electric fleet, it is as critical as the wheels or the windshield, and significantly more complex.

EVSE should be installed away from student buildings, if possible. With fire lanes, evacuation routes, curious children, and insurance and fire safety concerns to address, installing chargers close to or even on student occupied buildings should be carefully considered, or avoided if possible.

Consider installing an extra charger at the maintenance shop. Occasionally, buses need preventative maintenance or are taken out of service for extended periods. The buses will need a 'top up' before being brought back into service. Without a strict schedule to follow during these times, a cheaper, lower power charger may be easier to use, procure, and install.

Allowing drivers to take electric buses home overnight may pose some logistical challenges. While the pilot did not include any buses that were parked at driver homes, observations from the pilot can be applied to this scenario. Most of the expected challenges would come from the need to charge the bus overnight, which may require some infrastructure upgrades and a special billing arrangement. The simplest solution would be to charge the buses elsewhere, perhaps using a high-power fast charger, though at a higher cost. Other potential strategies to consider include setting up a new fleet-owned utility service at the driver's home and selecting chargers that are easier to remove if the employment relationship changes.

⁸ IJARIT Vol.3 Issue 3, "Energy Efficient Electric Vehicle Using Regenerative Braking System": 2017. <http://large.stanford.edu/courses/2017/ph240/leis-pretto1/docs/lakshmi.pdf>

Participating in this new electric bus market is no small task and many school districts will need significant support as they begin to electrify their bus fleets.

Entering the electric bus market at this time requires additional time and expense, familiarity with newer technology, as well as knowledge of funding and regulatory requirements. To be successful, school districts will likely require dedicated staff as well as external support from state and national resources. Until pricing comes down few districts will be able to enter this market without significant financial assistance.

Electric School Bus Results

The study tracked approximately 20 metrics for each of the six electric school buses in the pilot. For ease of understanding, these data are reported below in four categories: Performance, Reliability, Cost Savings, and Emissions.

Performance

Performance varied significantly across the pilot vehicles. All school buses successfully handled Vermont driving conditions across all road types during warm weather; Blue Bird buses struggled to stay operational in the winter, however. Drivers reported a small learning curve to becoming familiar with the regenerative braking features, but none reported that the vehicle felt any less safe to operate than a diesel bus when operating normally. STA expressed some concerns around decreased frame rigidity on the Lion buses. With the many mechanical issues experienced with the Blue Bird buses, FWSU drivers expressed a unique concern around getting stranded while on route or not being ready at the start of the day. Other fleets did not report this concern. Under normal operation, drivers overall reported being impressed by how similar driving an electric bus was to driving a diesel bus. Some drivers noted additional benefits such as a quieter ride, less noise in the cabin leading to calmer student passengers, and improved roominess. They also noted a few quirks that take getting used to, like how to avoid rolling backwards when starting from a full stop on a hill and finicky heater controls. Table 7 shows how the six electric school buses fared against the primary operational performance indicators.

Table 7: Electric School Bus Operational Indicators

	In-service rate [%]	Annual miles [mi]	Average daily trip total [mi]	Average real-world range between charges [mi]	Average efficiency [kWh/mi]	Average efficiency - MPG diesel equivalent [MPGe] ***
BUUSD/STA - Lion Bus 8019	60%	3991	37	74	2.1	16.3
BUUSD/STA - Lion Bus 8058	86%	5443	32	78	2.0	17.1
CVSD - Lion Bus 8020	73%	9988	75	101**	1.7	20.2
CVSD - Lion Bus 8056	100%	9998	51	94	1.8	19.1
FWSU - Blue Bird Bus 1981*	57%	5468	49	77	2.4	14.4
FWSU - Blue Bird Bus 1982*	29%	2507	44	89	2.5	13.7

* FWSU's Blue Bird buses range and efficiency values are likely overestimated. The buses had very few cold-weather data points, as they were mostly out of service during the months of January, February, and March.

** CVSD's Bus 8020 received a battery upgrade 7 months into deployment. Prior to the upgrade the real-world range was 81 miles, and after it was 132 miles. However, much of the first value's drive time included winter driving, while the latter did not.

*** Typical Type C diesel buses get a national average of 8.2 MPG according to the Argonne National Lab. [Argonne National Lab Alternative Fuel Life-Cycle Environmental and Economic Transportation \(AFLEET\) Tool – https://greet.es.anl.gov/afleet_tool](https://greet.es.anl.gov/afleet_tool)

Reliability

The in-service rate shown in Table 7 shows the number of days a vehicle was available for service as a percentage of the number of days when its service was needed. Lower percentages point to some of the mechanical issues encountered over the course of this pilot. It is not uncommon for a bus of any type to miss some service for preventative maintenance, minor repairs due to wear and tear, or mechanical breakage. Indeed, most fleets keep a small number of spare buses in reserve to cover issues like this or to convey stranded passengers. Careful tracking of the fleets' diesel vehicles availability was not within the scope of this pilot.

Figure 3 shows the various reasons for the pilot buses' outages. See [Appendix C](#) for further details. Most of the outages noted resulted in downtime of one to a few days. However, issues related to the drivetrain, mechanics, and thermal management resulted in weeks to months of lost service time.

Figure 3: Electric School Bus Outages by Category and OEM

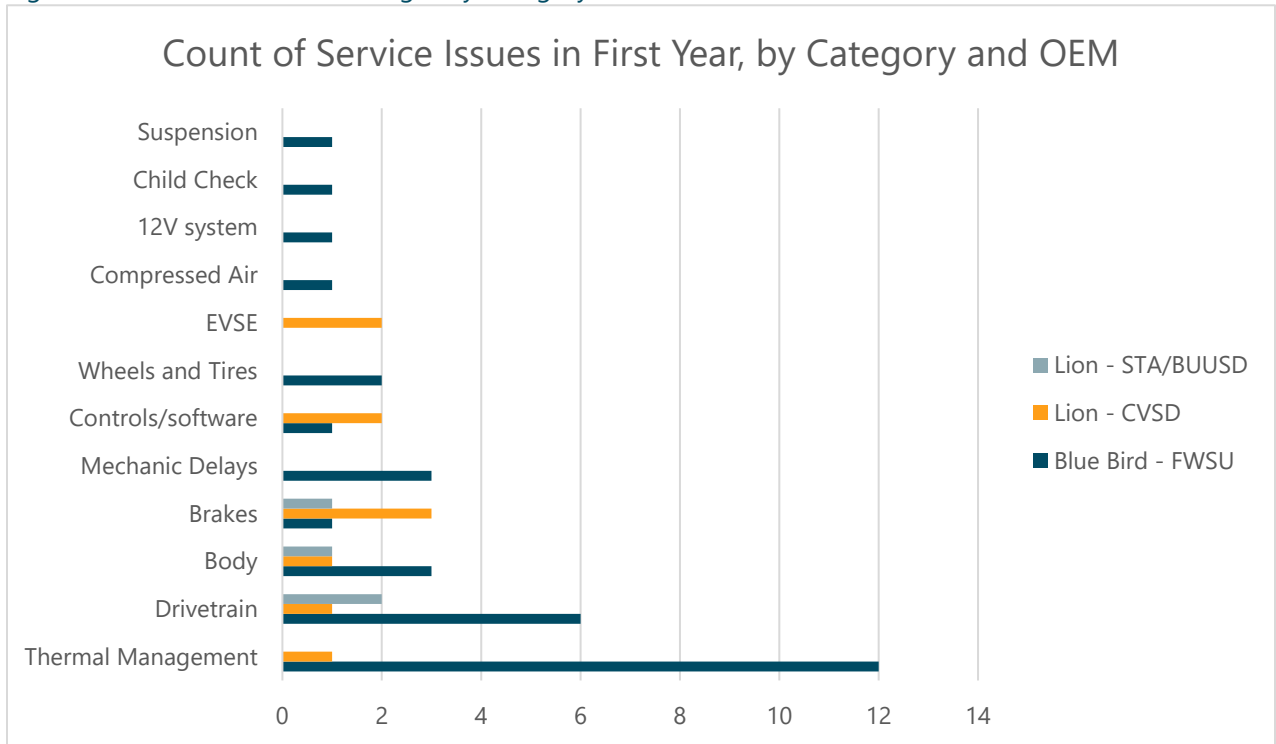

Cost Savings

Operational and maintenance cost savings are two of the primary advantages of an electric school bus. The relatively low cost and stable price of electricity compared to diesel combined with an overall more efficient drivetrain on electric buses can result in considerable reductions in annual fuel expenses. In addition, without an engine, transmission, engine exhaust, or many other components prone to wear and tear, maintenance savings can potentially outweigh fuel savings. Table 8 shows the annualized findings on operational expenses and savings garnered over an equivalent diesel bus of the same type.

Table 8: Electric School Bus Operational Costs and Savings

	Average electricity costs [\$/mi]***	Auxiliary heater diesel costs [\$/mi]	New diesel type C bus fuel costs [\$/mi]****	Savings [\$/mi]
BUUSD/STA - Lion Bus 8019*	\$0.36	\$0.06	\$0.66	\$0.24
BUUSD/STA - Lion Bus 8058*	\$0.34	\$0.07	\$0.66	\$0.25
CVSD - Lion Bus 8020	\$0.29	\$0.05	\$0.66	\$0.33
CVSD - Lion Bus 8056	\$0.31	\$0.04	\$0.66	\$0.32
FWSU - Blue Bird Bus 1981**	\$0.40	\$0.02	\$0.66	\$0.24
FWSU - Blue Bird Bus 1982**	\$0.43	\$0.00	\$0.66	\$0.23

* BUUSD/STA's Lion buses were discovered to be drawing power at a 1kWh rate even after the vehicle was done charging, to govern thermal management and keep the link with the charger open. CVSD's Lion buses had the same issue, but to a lesser extent due to charger faults. Those additional loses are included in the figures above.

** FWSU's Blue Bird buses' true energy and diesel costs were significantly higher than shown here. The buses were generally in-service only during the most efficient periods of the year. Also, the auxiliary heaters on those buses were not functioning properly for the first winter they were deployed.

*** Electricity costs are based on GMP's 2021-2022 commercial Rate 6 tariff price of \$0.17141/kWh - <https://greenmountainpower.com/rates/>

**** Diesel fuel costs are based on federally reported average area fuel prices seen over the evaluation period and an assumed MPG rating of 8.2 miles per gallon for a conventional diesel school bus, a figure gleaned from the Argonne National Lab AFLEET tool - [Argonne National Lab Alternative Fuel Life-Cycle Environmental and Economic Transportation \(AFLEET\) Tool - https://greet.es.anl.gov/afleet_tool](https://greet.es.anl.gov/afleet_tool)

Because electric buses in the pilot were still under warranty, the team did not have access to actual maintenance costs. This made it difficult to fairly determine and quantify equivalent costs of electric and diesel school bus maintenance. However, thanks to good record keeping at CVSD, the team compiled evidence of the maintenance savings on those vehicles. Comparing against CVSD's diesel fleet maintenance costs, the team estimated that one bus saved the district approximately \$1,500 for the year despite needing an emergency brake assembly repair and an auxiliary heater overhaul. The second bus needed no major repairs and saved the district approximately \$5,500 compared to the average cost of diesel school bus maintenance within that fleet.

Well-to-Wheel Emissions

Electric vehicles shine when it comes to emissions reductions. Even taking into consideration the small amount of diesel used to keep the cabins warm on the most frigid winter days, and the relatively unregulated nature of those heaters' emissions, the team found considerable emissions reductions for all buses in the pilot. More southern climates do not require the additional heating and could expect to see even greater reductions of air pollutants. Vermont's low-carbon-impact grid means that charging the primary batteries on these buses has a minimal GHG impact on the atmosphere. Given the range capabilities seen, and the options on larger battery packs, it would be

entirely feasible even in Vermont to forgo the auxiliary heating system for buses serving shorter routes. Not only would this reduce emissions of criteria pollutants, but it would likely further reduce the maintenance issues and costs seen on these electric buses.

Tables 9 shows the normalized well-to-wheel emission reductions as compared to the vehicles scrapped as part of the pilot’s requirements. Table 10 shows the well-to-wheel emission reductions compared to a new diesel bus. Observing the difference in NOx emissions makes it clear that new diesel buses are much better regulated for NOx. However, the amount of greenhouse gases (GHGs) emitted directly corresponds to the amount of diesel consumed in both cases. To account for the varying mileage and duration of evaluation across the buses, the team normalized values in both tables to a 10,000-mile annual mileage standard. See [Appendix A](#) for non-normalized results.

Table 9: Emissions Reductions Compared to the Scrapped Diesel Buses

	Normalized NOx reductions [lbs]	Normalized PM2.5 reductions [lbs]	Normalized PM10 reductions [lbs]	Normalized GHG reductions [short ton]
BUUSD/STA - Lion Bus 8019	79.5	0.3	19.9	8.3
BUUSD/STA - Lion Bus 8058	79.4	0.3	19.9	9.1
CVSD - Lion Bus 8020	153.7	9.9	11.0	11.3
CVSD - Lion Bus 8056	154.2	9.9	11.0	11.5
FWSU - Blue Bird Bus 1981	153.8	9.9	11.0	10.1
FWSU - Blue Bird Bus 1982	154.3	9.9	11.0	10.4

Table 10: Emissions Reductions Compared to a New Diesel Bus

	Normalized NOx reductions [lbs]	Normalized PM2.5 reductions [lbs]	Normalized PM10 reductions [lbs]	Normalized GHG reductions [short ton]
BUUSD/STA - Lion Bus 8019	18.2	0.1	0.1	8.3
BUUSD/STA - Lion Bus 8058	18.2	0.1	0.1	9.1
CVSD - Lion Bus 8020	18.2	0.1	0.1	11.3
CVSD - Lion Bus 8056	18.3	0.1	0.1	11.5
FWSU - Blue Bird Bus 1981	18.3	0.1	0.1	10.1
FWSU - Blue Bird Bus 1982	18.4	0.1	0.2	10.4

In both tables above, some of BUUSD/STA's values differ significantly from the results of other electric buses. BUUSD/STA scrapped buses that were built *after* the EPA enacted significantly more stringent emissions standards for NOx. BUUSD/STA buses also used approximately 50% more diesel auxiliary heater fuel than the other buses, likely due to variations in fleet operations.

Barre Unified Union School District / Student Transportation of America

Fleet Characterization

Location

Barre Unified Union School District (BUUSD) participated in partnership with Student Transportation of America (STA), a third-party vendor supporting school bus fleets across Vermont. STA's fleet provides bus service to the Barre Unified Union School District, a district that includes Barre City Elementary & Middle School (Grades PreK-8), Barre Town Middle & Elementary School (Grades PreK-8), and Spaulding High School/Central Vermont Career Center (Grades 9-12). These schools are all located in central Vermont among the Green Mountains in Washington County.

Terrain and routes

The terrain in the Barre school district is quite hilly with many long grades leading down into the valleys. In the valleys, as well as along the ridge lines, roads are much flatter, but are substantially more curved due to being developed around several small streams and rivers. Much of the building infrastructure is concentrated in areas where the ground is less pitched. Of the bus routes used by electric buses in this pilot, 90% are paved and 10% are unpaved. Approximately 30% of the route miles pass through urban development, and the rest are rural. The elevation change, from the lowest point to the highest is roughly 600 feet.

Charging Sites

Initially, the team planned to install charging stations at STA's bus depot in Williamstown, 6.5 miles southwest of Barre Town Middle and Elementary School. However, considering the distance from the school and selected routes, a desire to enhance student and community interest, and the reduced effort and overall cost required, the team decided to install chargers at the school itself. Balancing the effort of installation with safety concerns, the team decided to adopt the pedestal mount option for chargers and to install them in front of the school near the location where buses pick up and drop off students. A nearby pole provided three-phase power and GMP installed a new transformer and service to support the chargers. The school also installed a new light on the side of the building to aid in operating the chargers during the dark winter months.

Image 1: Charging Configuration at BUUSD

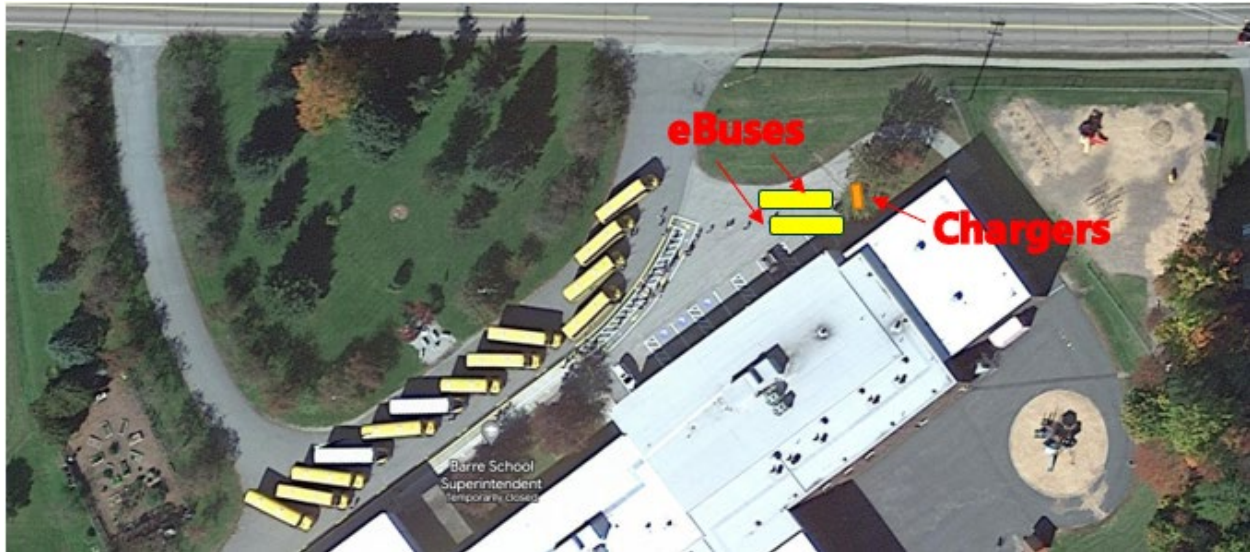

Weather

The buses in Barre provided well-clustered data showing how outdoor ambient air temperature affects range. As Figure 4 shows, the two buses lost roughly 1% of range for every 3 degrees in temperature drop below ~75 degrees F. The two bus routes require 32-37 daily miles of travel and the buses have a nominal range of 100 miles under optimal conditions. Thus, the buses should have no trouble covering the chosen routes, without mid-day charging, even under the worst temperature conditions. At -15 degrees F, for example, (90 degrees below optimum), the buses in Barre would be expected to lose 30% of range. Additionally, as Figure 4 shows, the buses experienced ~10% less range than nominal even in optimal temperatures. Yet even with this decreased range, at the coldest temps the buses easily travelled their 35-mile routes.

As noted above, Figure 4 also shows that the buses rarely saw real-world ranges in excess of 90% of the nominal range – or 90 miles. While there are many possible reasons for this, contributing factors may be the relatively shorter routes on which they were used, and the fact that they were charged up at mid-day. Together, these factors meant that the state-of-charge rarely dropped below 85%. With Barre’s rolling terrain, the buses expended much energy to travel uphill, but without much battery left to fill, regenerative braking had limited ability to allow the bus to regain that lost energy when traveling downhill. Given that the bus chargers currently sit near the highest point of the routes, this may continue to be an issue so long as the chargers remain at the school. One mitigation strategy would be to not fully charge bus batteries and instead leave room for the regenerative drive to store its recaptured energy.

Figure 4: BUUSD/STA Bus Ranges vs. Ambient Temperature

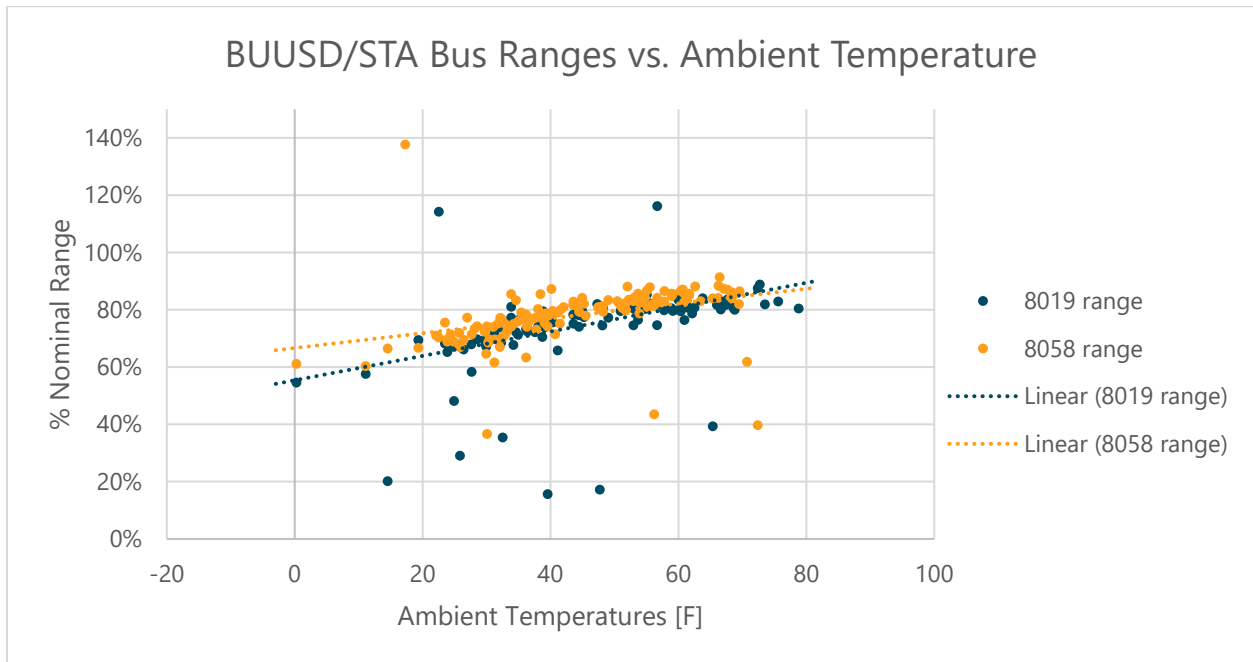

Fuel Cost Savings

To provide a fair and informative comparison between each district's buses and their fuel savings over a diesel bus baseline, the team normalized the data in Table 11 (and in each school district's 'Fuel Cost Savings' tables below). The fuel and electricity usage data were first divided by the miles driven and then multiplied by an assumed annual mileage of 10,000 miles. The team selected this standard mileage based on nationally reported averages of school bus miles travelled per year (~12,000 miles) and data collected on buses in the project partner fleets (averaging around 8,500 miles). In their first year of operation, bus 8019 and bus 8058 amassed only 3,991 miles and 5,443 miles, respectively. The BUUSD/STA team selected shorter routes for the first year of electric bus usage to make sure that real-world ranges would not affect fleet operations. Based on the range findings in this report, STA has stated that they will consider expanding usage of the electric buses in the future.

Table 11: BUUSD/STA Fuel Cost Consumption and Savings

	Baseline diesel avoided [gal]	Energy consumed [MWh]	Aux. heater diesel consumed [gal]	Diesel fuel cost avoided [\$]	Electric fuel costs [\$]	Diesel fuel costs [\$]	Total operational savings [\$]
BUUSD/STA - Lion Bus 8019	1,220	26.8	75.4	\$6,353	\$4,592	\$386	\$1,374
BUUSD/STA - Lion Bus 8058	1,220	23.3	84.5	\$6,475	\$3,991	\$431	\$2,053

Vehicle Efficiency

BUUSD/STA buses experienced mixed results when it came to vehicle efficiency. As noted in the discussion of range versus temperature above, the elevation of the school and charging station relative to the elevation of the routes likely contributed to lower efficiency of BUUSD/STA buses when compared to buses in the CVSD. Phantom loading, discussed below, also had a more pronounced effect at the Barre school due to the longer sit times when the buses were plugged in but not actively charging.

Bus 8019 had an overall operational efficiency—total energy drawn off the grid divided by total miles driven—of 2.1 kWh/mi. Bus 8058 had an average operational efficiency of 2.0 kWh/mi. The base model Lion Type C electric school bus has a useful battery size of 129 kWh and a nominal range of 100 miles, thus giving it a nominal on-road efficiency of 1.3 kWh/mi. This on-road efficiency looks only at energy consumed while travelling and does not include losses at the charger or phantom loading. This report focused on operational efficiency because the needed input values are more readily available and reliable, and because this is the data fleet managers need to project budget and expenses.

Electric Load Profiles (and Phantom Loading)

As school bus fleets convert more of their vehicles to electric drivetrains, the timing and degree of power draw on the grid will become increasingly important to consider. This is because time-of-use rates are often applied to large, commercial load centers by utilities. If charging can be kept to a minimum during the utility's peak usage times and the load can be shifted into the off-peak period, many thousands of dollars can be saved over the course of a year. For example, the electric load profile at BUUSD is quite regular, with the buses leaving the school each day around 7 a.m. and returning and plugging back in around 9 a.m. The buses start their afternoon routes around 2 p.m. and are finished and plugged back in around 4 p.m. Figure 5 below, shows the average loading across the study period. Some small variation occurs in the early morning and mid-day hours, enough so that it minorly impacts the shape of the average. Figure 6 shows the actual load profile from a selected day of service and displays the expected 'tabletop' shape to a single charge event profile. However, as shown in both graphs, charging typically lasts about an hour, due to the shorter routes used for these two buses as compared with the other schools. If the district is moved into a time-of-use utility rate, these peak period charges could become significantly more expensive. All of the districts would thus benefit from consideration of managed charging strategies to better manage both the timing and power level of their electric demand.

Figure 5: BUUSD/STA Daily Load Profiles as Percent of Max Loading

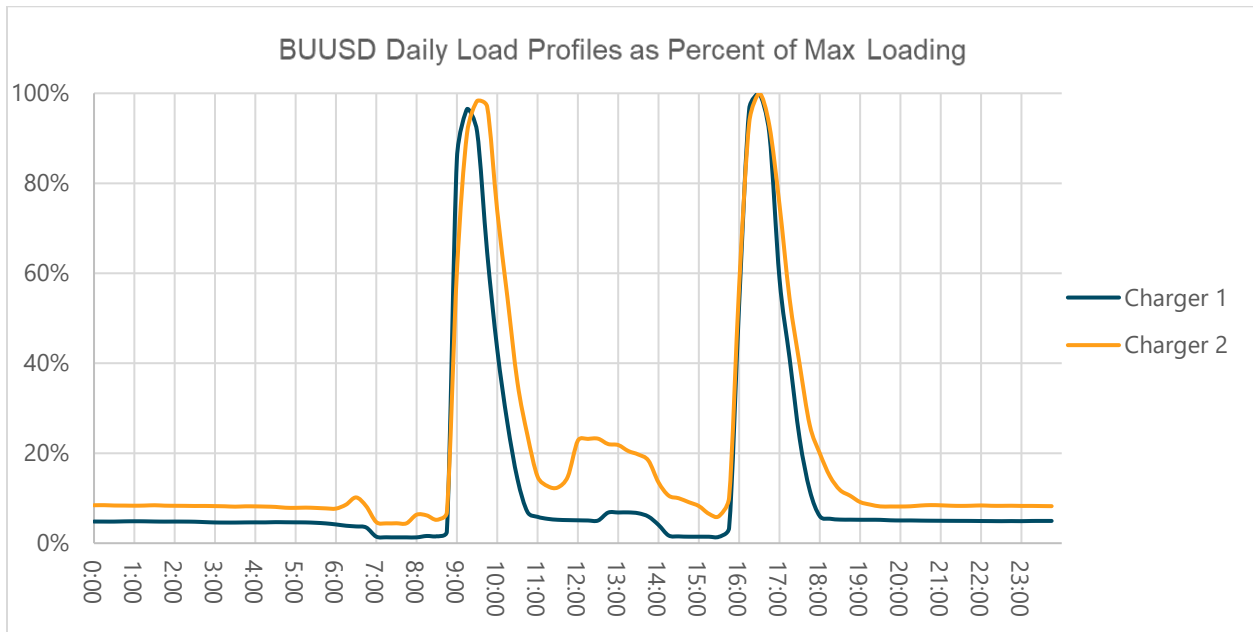

Figure 6: BUUSD/STA Sample Charger Load Profile

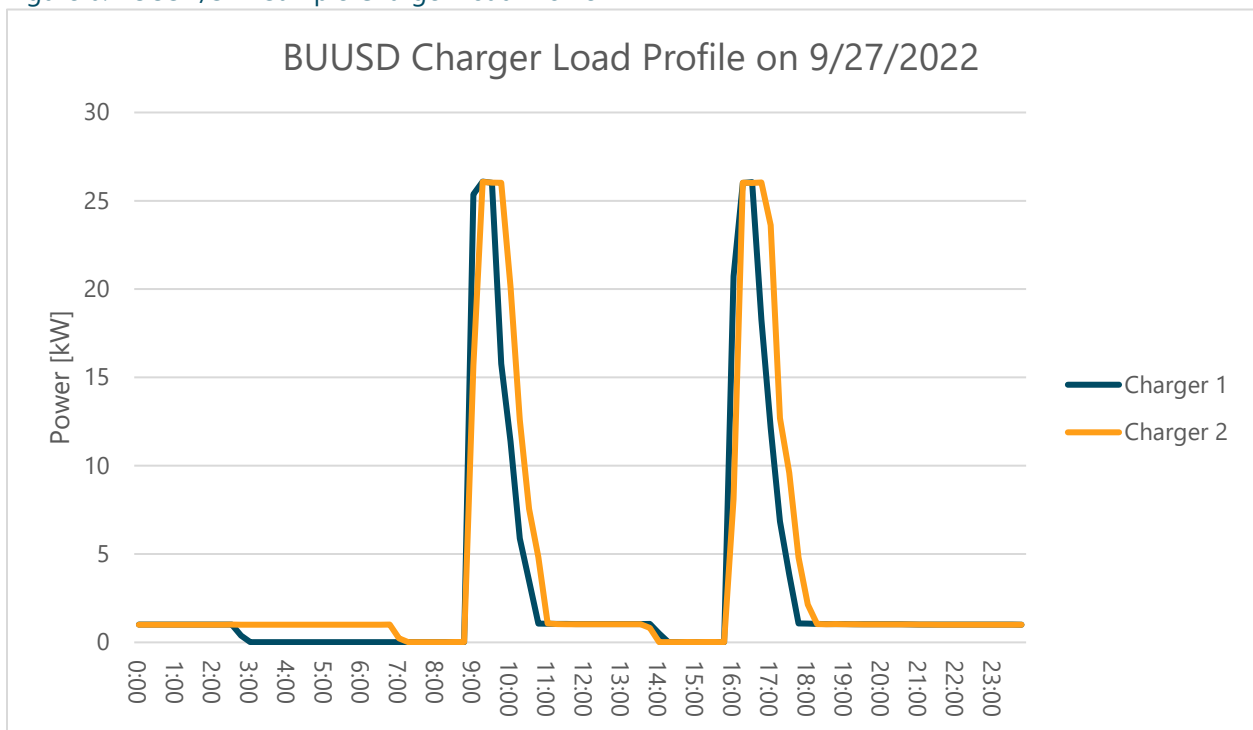

Figure 6 also displays another anomaly that the team discovered part way through the pilot. The data show that the charge level carries a ‘phantom load’ of roughly 1 kW whenever the bus is plugged-in but not actively charging. The team informed STA of this information and STA sought feedback from Lion. Lion explained that if the bus is not drawing any power, then the charger will terminate the charge session until the plug has been pulled and reinserted. However, to keep its batteries at

optimal temperatures when there is no grid power to draw from, the bus will pull that energy off the batteries which results in a less than full battery when the driver arrives the next day. Thus, it is by design that this 1kW load is allowed to persist, but it can add up to 18-24 kWh of extra energy consumption per day, and up to 6,000 to 8,000 kWh per year. The project team included that energy in its calculations. If the issue can be remedied, the Lion buses will have even stronger performance and cost results.

Fuel Use and Emissions Reductions

As Tables 12 and 13 show, the two buses at BUUSD/STA performed quite similarly on environmental metrics. This is not surprising given that the two vehicles are nearly identical and travelled very similar routes. During the monitoring period, Bus 8019 travelled 2,991 miles while Bus 8058 travelled 5,443 miles. The data below has been normalized to a 10,000 annual mile standard. The tables show that reductions of nitrogen oxides (NOx) and particulate matter (PM, 2.5 micrometers [µm] and 10 µm) are higher when using the scrapped buses as the baseline than when comparing to a new diesel bus.

As discussed in the emissions section above, these emissions reductions were lower for BUUSD/STA than for other districts because of changes in bus emission standards. Between 2004 and 2009, the Environmental Protection Agency made a series of changes to emissions standards, including those for school buses.⁹ The manufacture date of the scrapped buses therefore affects how much emissions they produce. Since BUUSD/STA buses were slightly newer than scrapped buses in other districts, they fell under the newer emissions standards and therefore demonstrated lower reductions compared to the scrapped buses in the pilot’s other school districts. Also, the auxiliary heaters installed by the vehicle manufacturer are not as well-regulated as diesel drivetrains are when it comes to emissions. This accounts for the large difference in NOx emissions between the two scenarios, as well as reducing the particulate matter savings to almost zero when comparing against a new diesel bus.

Table 12: Environmental Performance Metrics Bus 8019

Electric bus 8019 vs. scrapped diesel bus 0817		Electric bus 8019 vs. a new diesel bus	
Fuel gallons avoided [gal]	1,099	Fuel gallons avoided [gal]	1,099
NOx reduction [lbs]	79.5	NOx reduction [lbs]	18.2
PM2.5 reduction [lbs]	0.3	PM2.5 reduction [lbs]	0.1
PM10 reduction [lbs]	19.9	PM10 reduction [lbs]	0.1
GHG reduction [short tons]	8.3	GHG reduction [short tons]	8.3

⁹ EPA; “Timeline of Major Accomplishments in Transportation, Air Pollution, and Climate Change”, <https://www.epa.gov/transportation-air-pollution-and-climate-change/timeline-major-accomplishments-transportation-air>

Table 13: Environmental Performance Metrics Bus 8058

Electric bus 8058 vs. scrapped diesel bus 6128		Electric bus 8058 vs. a new diesel bus	
Fuel gallons avoided [gal]	1081	Fuel gallons avoided [gal]	1081
NOx reduction [lbs]	79.4	NOx reduction [lbs]	18.2
PM2.5 reduction [lbs]	0.3	PM2.5 reduction [lbs]	0.1
PM10 reduction [lbs]	19.9	PM10 reduction [lbs]	0.1
GHG reduction [short tons]	9.1	GHG reduction [short tons]	9.1

Maintenance and Reliability (in brief)

The number of in-service days for the two Lion Electric buses fell into the mid-range – Bus 8019 was available for use for 60% of the days it was scheduled, while Bus 8058 was in-service for 86% of its scheduled days. Yet, over the 12-month monitoring period, these buses experienced the lowest number mechanical issues. These issues included a critical issue with a lithium battery pack on Bus 8019 requiring a battery replacement by the manufacturer, which was covered under the warranty. Other issues included fuse shortages which indicated the need for a wiring harness replacement, an issue with the e-brake assembly, and a broken corner-front window (from a rock strike). The broken window would not usually be counted against the bus, but extended delays in procuring a replacement (over three weeks) warrant consideration. In general, STA technicians reported that parts of any kind on the Lion buses took longer than expected to procure.

The other significant and continuing issues for BUUSD/STA were related to the chargers. Covid-related supply chain delays meant that the ABB chargers selected by Lion for the site could not be procured prior to bus delivery. Instead, temporary Delta chargers had to be installed. Initially, these chargers were to be mounted on a pedestal roughly 20 feet from the building. A last-minute change repositioned them to be mounted on the side of the building itself. Once in use, the team realized this was not an ideal setup because of fire lane restrictions and vehicle parking flow. Thus, once the ABB chargers arrived, the team decided to return to the initial pedestal mount plan and bring a new electrical service line over from a nearby pole. Unfortunately, the electrician placed the pedestal in the wrong location. It had to be moved some 30 feet and the electrical line extended. To save money and effort, the electrician simply extended the utility line from the first location using a partially buried junction box. Unbeknownst to the electrician, that junction box sat in a position where a winter plow truck usually piles snow. Indeed, the plow truck damaged the junction box and water penetrated it causing an arc event. No parties were injured, but most of the electrical work needed to be re-done the following summer once the ground had thawed.

The ABB chargers selected by Lion appeared to fault and stop charging somewhat randomly. The team speculated that this may be related to power conditions fluctuating as the chargers came online. CVSD’s Lion buses and ABB chargers experienced a very similar issue. At both locations, only one bus at a time seems to be able to utilize the ABB chargers without faulting out. As a result, although BUUSD/STA intended the wall-mounted Delta chargers to be temporary, they have remained in place for the duration of the monitoring period and have been actively used by at least one bus throughout.

Champlain Valley School District

Fleet Characterization

Location

The Champlain Valley School District provides busing services to six schools: Charlotte Central School in Charlotte, VT; Hinesburg Community School in Hinesburg, VT; Shelburne Community School in Shelburne, VT; Allen Brook School and Williston Central School both located in Williston, VT; and Champlain Valley Union High School located in Hinesburg, VT. All of these towns are in Chittenden County—Vermont’s most populated county—in western Vermont’s Champlain Valley. They often house commuters who work in the greater Burlington metro area.

Terrain and routes

The two CVSD buses served routes in and around Williston where terrain is relatively less pitched than much the rest of the state. The buses travelled two main assigned routes. The first of these includes approximately 25-30 miles of paved roads with the lowest elevations being at the beginning and ends of the trip. The greatest elevation change along the route is approximately 600 feet, though most driving occurs within a 200-foot elevation band. The second route overlaps the first and is also paved for its approximately 85-mile length. It has similar elevation changes, but slightly more travel on state highways. Both routes start and end at the Allen Brook School. The furthest point of both routes is Champlain Valley Union High School where the bus maintenance shop is located.

Charging Sites

Allen Brook School provided the charging site for this project partner and its students were the primary riders for these buses. From a planning perspective, Allen Brook School was the least expensive and least problematic. In previous years, temporary classroom trailers and a power panel on separate service with amply sized breakers had been installed on the area that is now the bus yard. This existing equipment enabled easy conversion for bus chargers now that the trailers have been removed. The panel also connects to the school’s small solar array. The two 100-amp ABB chargers provided by Lion Electric were powered with 240VAC service and delivered DC power to the buses. This resulted in a nominal max power output of 22.5 kW.

The district also decided to install a Level 2 charger at the high school maintenance shop where the buses are maintained. This expense was not covered by the pilot, but the charger was often used to ‘top up’ the buses when they were in for any prolonged service needs.

Image 2: Charging configuration at Allen Brook School, Williston

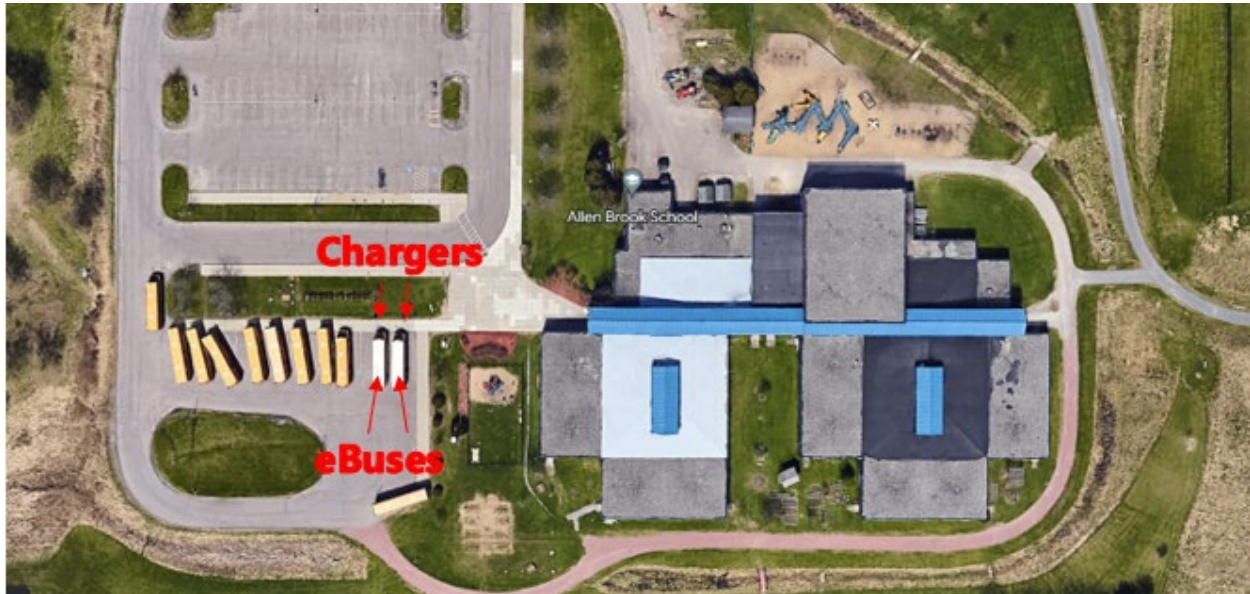

Weather

The weather in the Champlain Valley is slightly milder than most the rest of the state although in a state this size, regional weather variations tend to be subtle. Focusing only on the hours when buses were operating, the annual-average temperatures between all project partner sites varied by only 4 degrees, with CVSD right in the middle. CVSD experienced conditions that included both the coldest and the warmest data points among all school districts in this study during bus operation.

As Figure 7 shows, comparing vehicle range and ambient temperatures, produces a fairly well clustered grouping with some outlying data points. These data indicate that buses achieved nominal ranges when operating between 55-65 degrees F. Range declined approximately 1% for every 2-degree F drop in temperature. When ambient temperatures neared 0 degrees F, nominal range had dropped by approximately 30%.

Figure 7: CVSD Bus Ranges vs. Ambient Temperatures

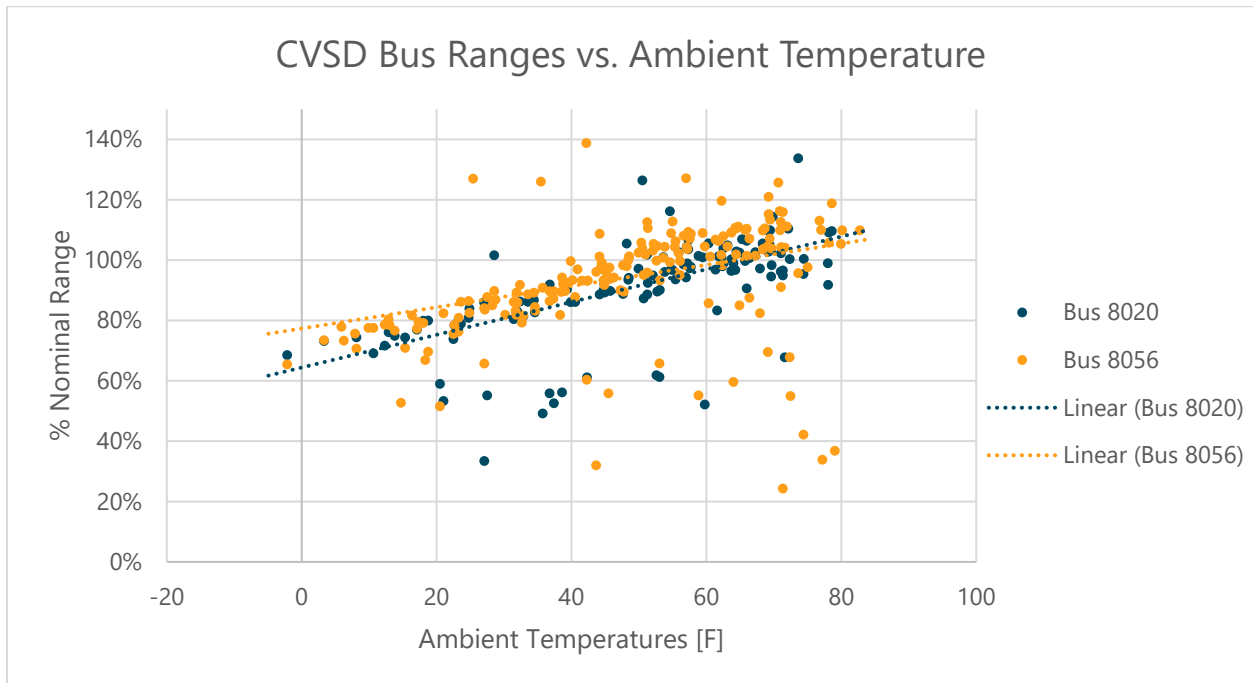

Fuel Cost Savings

Of all school districts in the pilot, CVSD’s electric buses produced the highest savings as compared with conventional diesel buses. Its electric buses travelled the longest routes in the pilot and those were entirely paved routes with relatively little elevation change. CVSD also had the fewest out-of-service days among the districts. As with other fuel cost savings results, the data in Table 14 has been normalized by calculating savings on a per-mile basis and converting to an annual mileage of 10,000 miles. Actual mileage for CVSD buses came very close to 10,000. During the pilot year, Bus 8020 traveled 9,988 miles and Bus 8056 traveled 9,998 miles.

Table 14: CVSD Fuel Cost and Consumption Savings

	Baseline diesel avoided [gal]	Energy consumed [MWh]	Aux. heater diesel consumed [gal]	Diesel fuel cost avoided [\$]	Electric fuel costs [\$]	Diesel fuel costs [\$]	Total operational savings [\$]
CVSD - Lion Bus 8020	1,220	16.6	88.6	\$5,324	\$2,854	\$353	\$2,117
CVSD - Lion Bus 8056	1,220	17.1	67.5	\$5,459	\$2,928	\$302	\$2,228

Vehicle Efficiency

Given the flatter, paved roads, and longer routes at CVSD it is not surprising that its buses had very good efficiency results. Bus 8020 had an overall average efficiency of 1.7 kWh/mi while Bus 8056 operated at a slightly less efficient 1.8 kWh/mi. The base model Type C electric school bus offering from Lion indicates an efficiency closer to 1.3 kWh/mi. This rating typically assesses the on-road efficiency value—or battery energy use per mile driven. The values in this study show total operational efficiency. It is calculated by dividing the number of kWh that must be purchased from the utility by the number of miles travelled. The main difference between the two approaches is that operational efficiency also accounts for efficiency losses on the charger and thermal management draws when the bus is parked. It is more accurate to look at operational efficiency when considering the total costs of ownership.

Converting operational efficiency numbers into a miles per gallon of diesel use equivalent shows that Bus 8020 had an equivalent fuel economy of 20.2 MPGe and Bus 8056 had an equivalent fuel economy of 19.2 MPGe. The Argonne National Labs AFLEET tool sets average diesel school bus economy at 8.2 MPG.

Electric Load Profiles (and Phantom Loading)

As seen in the chart below, CVSD tended to charge its buses twice each day, once after completing the morning run and then again after the afternoon run. The slightly higher lines in the afternoon indicate that occasionally drivers felt comfortable completing both runs on a single charge (or experienced a charger fault mid-day and could not complete the charge. See more discussion of this EVSE issue in the maintenance section below.) In this case, max loading slightly exceeded 21 kW for both chargers, rather than the 22.5 kW nominal output advertised by ABB.

Figure 8 shows a power draw profile averaged across a year's worth of charging. It does not reflect the squarer shaped 'tabletop' curve that the buses exhibit during an actual charge event.

Figure 8: CVSD Daily Load Profiles as Percent of Max Loading

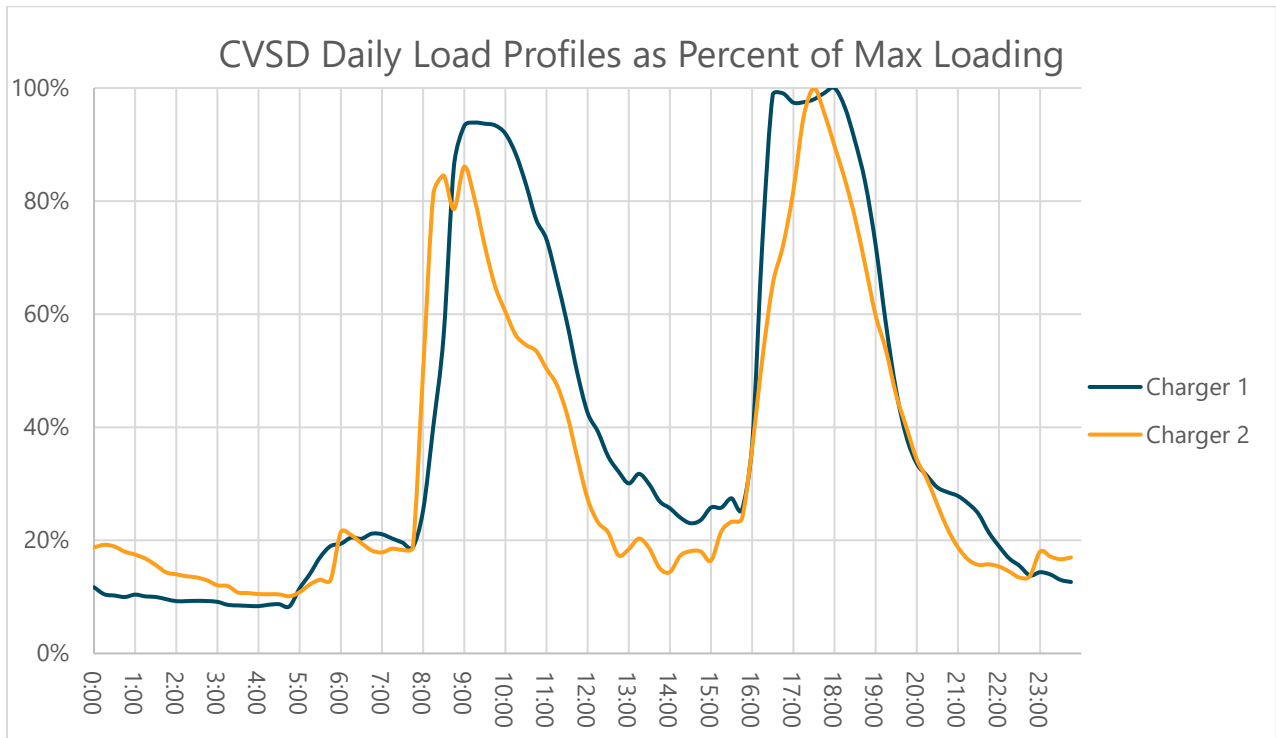
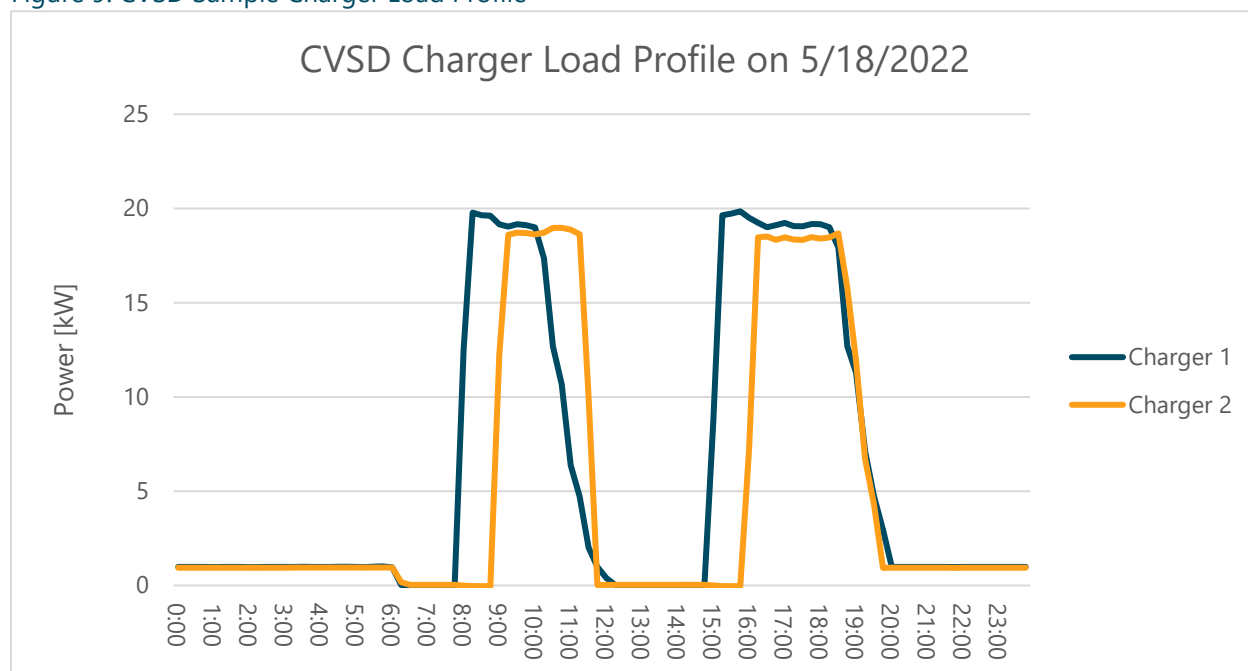

Figure 9 below shows a single day's actual recorded demand values. It clearly shows that the load never truly goes to 0 kW but maintains a 'phantom load' that stays steady at about 1 kW. Lion buses at both CVSD and BUUSD/STA experienced this phenomenon, the result of an intentional design setting by Lion to maintain the open link between the bus and the charger. With this feature, if the bus needs overnight energy for its thermal management system to keep the lithium batteries at the optimum temperature, it can draw that power off the grid rather than use its own reserves. All six buses in the study faced the issue that if that link was shut down at the end of a charge session, then it could not be re-engaged until the bus had been manually unplugged and re-plugged. Blue Bird avoided the extra energy usage by letting the link close, while Lion left it open to ensure the bus was filled when drivers arrived.

Figure 9: CVSD Sample Charger Load Profile



Unfortunately, pulling 1kW demand during much of the bus downtime added to the cost of the electric buses. A vehicle drawing 1 kW for half of its day adds up to 4,380 kWh a year in unneeded electrical bills—over \$700 per bus. If bus OEMs can solve this issue as they are attempting to do with software upgrades, then Lion buses could see their energy usage cut by 25%, further improving the findings. Blue Bird buses might likewise face fewer thermal management issues if power could be drawn on demand from the grid only when the bus needs it.

Fuel Use and Emissions Reductions

Buses with higher mileage showed improved efficiency. This coupled with the older age of the scrapped buses resulted in the pilot’s highest emissions reductions and highest avoided diesel fuel rates accruing to CVSD buses. Tables 15 and 16 summarize these findings.

Table 15: Environmental Performance Metrics Bus 8020

Electric bus 8020 vs. scrapped diesel bus 4805		Electric bus 8020 vs. a new diesel bus	
Fuel gallons avoided [gal]	1,131	Fuel gallons avoided [gal]	1,131
NOx reduction [lbs]	153.7	NOx reduction [lbs]	18.2
PM2.5 reduction [lbs]	9.9	PM2.5 reduction [lbs]	0.1
PM10 reduction [lbs]	11.0	PM10 reduction [lbs]	0.1
GHG reduction [short tons]	11.3	GHG reduction [short tons]	11.3

Table 16: Environmental Performance Metrics Bus 8056

Electric bus 8056 vs. scrapped diesel bus 6367		Electric bus 8056 vs. a new diesel bus	
Fuel gallons avoided [gal]	1,152	Fuel gallons avoided [gal]	1,152
NOx reduction [lbs]	154.2	NOx reduction [lbs]	18.3
PM2.5 reduction [lbs]	9.9	PM2.5 reduction [lbs]	0.1
PM10 reduction [lbs]	11.0	PM10 reduction [lbs]	0.1
GHG reduction [short tons]	11.5	GHG reduction [short tons]	11.5

The two scrapped CVSD buses were manufactured in 2004 and 2005, before 2007 when the EPA tightened emissions standards for NOx and particulate matter (PM, 2.5 µm and 10 µm). This changed regulatory framework explains the difference in emissions reductions between scrapped diesel buses and new diesel buses in Tables 15 and 16 above. Also, the auxiliary heaters installed by the vehicle manufacturer are not as well-regulated as diesel drivetrains are when it comes to emissions. This accounts for the large difference in NOx emissions between the two scenarios, as well as reducing the particulate matter savings to almost zero when comparing against a new diesel bus.

Maintenance and Reliability (in brief)

Although the Lion buses at CVSD experienced maintenance troubles, these two buses had the highest in-service rates seen in this pilot. Indeed, Bus 8056 achieved a perfect attendance record, operating 196 days out of 196 days. Bus 8020 spent a few days in maintenance for a stuck parking brake, a critical thermal management fault, and a high-voltage interlock sensor fault.

The district also planned to purchase a Type D school bus, but that model was not ready in time and Lion provided a Type C ‘loaner’ for the interim period. After several months, CVSD decided to accept a battery upgrade to the Type C bus and take full ownership of it in lieu of purchasing the more expensive Type D model. Lion completed the upgrade at its facility in Canada which took the bus out of service for a month. However, since this was an upgrade rather than a repair, the out-of-service time did not count against the bus in the data provided in this report.

One ongoing issue still is not resolved for the school district, a charger that faults out somewhat randomly. Once plugged in and charging, both buses will occasionally experience a charger fault that stops the power supply. So far, the district has managed this issue by periodically checking on the buses to see if the charge session needs to be restarted. Lion is developing software upgrades to eliminate the issue.

Franklin West Supervisory Union

Fleet Characterization

Location

The Franklin West Supervisory Union is about 30 minutes northeast of Burlington and serves the towns of Georgia, Fletcher, and Fairfax, Vermont. Georgia and Fletcher contract out their transportation, while Fairfax owns its own buses. The Fairfax school, Bellows Free Academy, has a single, full-time mechanic who services the entire fleet, but major repairs must be taken to the Burlington area for service. Bellows Free Academy enrolls roughly 1,000 students from mostly rural surrounding areas.

Terrain and routes

FWSU's electric buses served Bellows Free Academy in Fairfax. The routes traversed many kinds of road, approximately 30% of which were unpaved. The routes in Fairfax included 400 feet of elevation change, less extreme than elevation changes in the other two school districts in the pilot. Although the elevation gains were not the most significant, the routes include many hills, some of which are very steep. One route includes a hill notorious for being difficult to navigate in slippery conditions with conventional diesel-powered buses. The drivers report that the increased power output to the wheels of the electric buses made that route easier to navigate safely.

Charging Sites

The bus yard is located at the far end of the Bellow Falls Academy athletic fields. Power for bus chargers came from a small office and two-door maintenance shop in the bus yard. Though the existing transformer and utility line provided sufficient power, the chargers required a panel upgrade. Additional conduit also had to be installed to reach the two pedestal locations out in the yard. With three-phase power available, the two Nuvve 80-amp Level 2 chargers were run on a 208 VAC service, resulting in a max power output of 16.6 kW.

Images 3 and 4: Site and charging configuration at Bellows Free Academy, Fairfax



Weather

Figure 10 below shows that the range vs. temperature data for FWSU exhibited more scatter than the other two schools. Nevertheless, a clear trend still appears, showing a loss of range of roughly 1% of nominal range for every 1-degree Fahrenheit drop in ambient temperature. The vehicles appear to achieve their nominal ranges at about 80 F. Though starting from a slightly higher nominal range than the Lion buses at the other two schools (120 miles versus 100 miles), the FWSU Blue Bird buses rarely reach that nominal range. Based on the trend observed from the data collected, at any temperature below 10 degrees Fahrenheit, the data suggests these buses would have been unable to provide adequate range to cover most routes at the school while maintaining a reasonable buffer.

It is unclear why the Blue Bird buses experienced a steeper range loss as temperatures cooled. Neither bus's auxiliary heater functioned during the first winter in service. It would be expected that

relying on the batteries to provide auxiliary heat would reduce range, but this study did not confirm that hypothesis. In the second year, diesel heaters were adjusted to properly provide auxiliary heat, but there was little change to the reported range data. It is surmised that this reflects the lack of data collected from operation of these buses during the pilot’s winter months. Both buses experienced significant thermal management issues throughout the pilot and were out of service for the majority of the coldest months.

Figure 10: FWSU Bus Ranges vs. Ambient Temperature

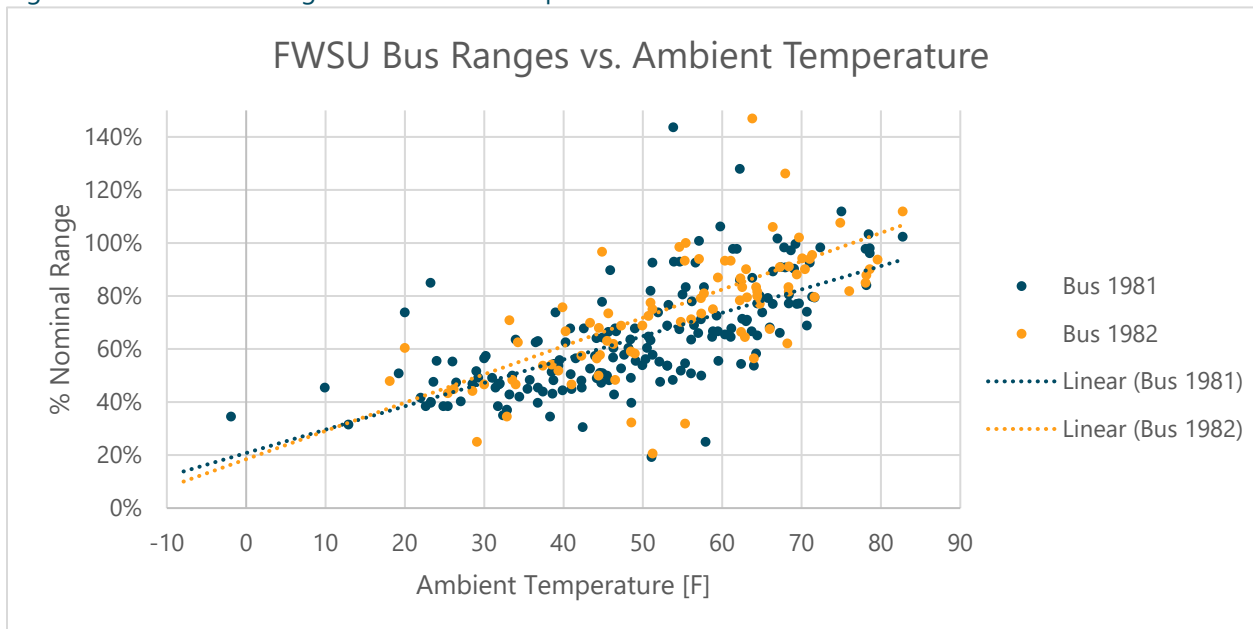

Annualized Fuel Cost Savings

Because the FWSU Blue Bird buses were out of service for the coldest months of the pilot’s first year, the team collected data through the following year as well. Unfortunately, the buses were also out of service for most of the second winter of the pilot and the team, therefore, captured very little data during the more inefficient periods of the fleet’s operation. To normalize the data, the team divided both years of fuel cost and savings data by the number of miles driven to arrive at per-mile values. These were normalized to the same 10,000-mile per year standard applied to the other districts. In FWSU, Bus 1981 travelled 9,113 route miles over the course of 20 months, while Bus 1982 travelled 4,179 miles in the same period. Though normalized for a better comparison against the buses at the other districts, the lack of winter data has inflated the results in Table 17 to an unknown degree. These results are certainly higher than would be expected under real-world conditions.

Table 17: FWSU Fuel Cost and Consumption Savings

	Baseline diesel avoided [gal]	Energy consumed [MWh]	Aux. heater diesel consumed [gal]	Diesel fuel cost avoided [\$]	Electric fuel costs [\$]	Diesel fuel costs [\$]	Total operational savings [\$]
FWSU - Blue Bird Bus 1981	1,220	22.8	52.7	\$5,646	\$3,901	\$247	\$1,499
FWSU - Blue Bird Bus 1982	1,220	23.9	0.0	\$5,497	\$4,088	\$0	\$1,408

Vehicle Efficiency

As with other metrics, the limited winter data makes it difficult to evaluate the operational efficiency of FWSU’s buses. Using available data, Bus 1981 showed an operational efficiency—total energy consumed from the grid divided by miles driven—of 2.4 kWh/mi. Bus 1982 had an operational efficiency of 2.5 kWh/mi. Per manufacturer specifications, the Blue Bird buses have a nominal battery size of 155.4 kWh, 124.6 kWh of which is estimated to be usable (accounting for reserves). The vehicles have a nominal range of 120 miles. These specifications indicate that on-road efficiency is 1.0 kWh/mi, or even less if accounting for regenerative braking. However, this on-road efficiency figure does not include stand-by losses on the charger or thermal management draws when the bus is parked. For all buses in this pilot, total operational efficiency was selected as a more salient metric to better indicate the true costs of ownership.

Converting the above noted efficiencies into the more familiar MPGe (miles per gallon equivalent), Bus 1981 had an operational fuel economy of 14.4 MPGe and Bus 1982 had an operational fuel economy of 13.7 MPGe. Putting that in perspective, the average diesel school bus economy used in the Argonne National Labs AFLEET tool is 8.2 MPG.

Electric Load Profiles

Figure 11 shows the two-hump load profile witnessed on FWSU’s chargers over the course of the pilot evaluation. The data blend various power levels on various days to produce an average value for each time slot of the day.

Figure 11: FWSU Daily Load Profiles as Percent of Max Loading

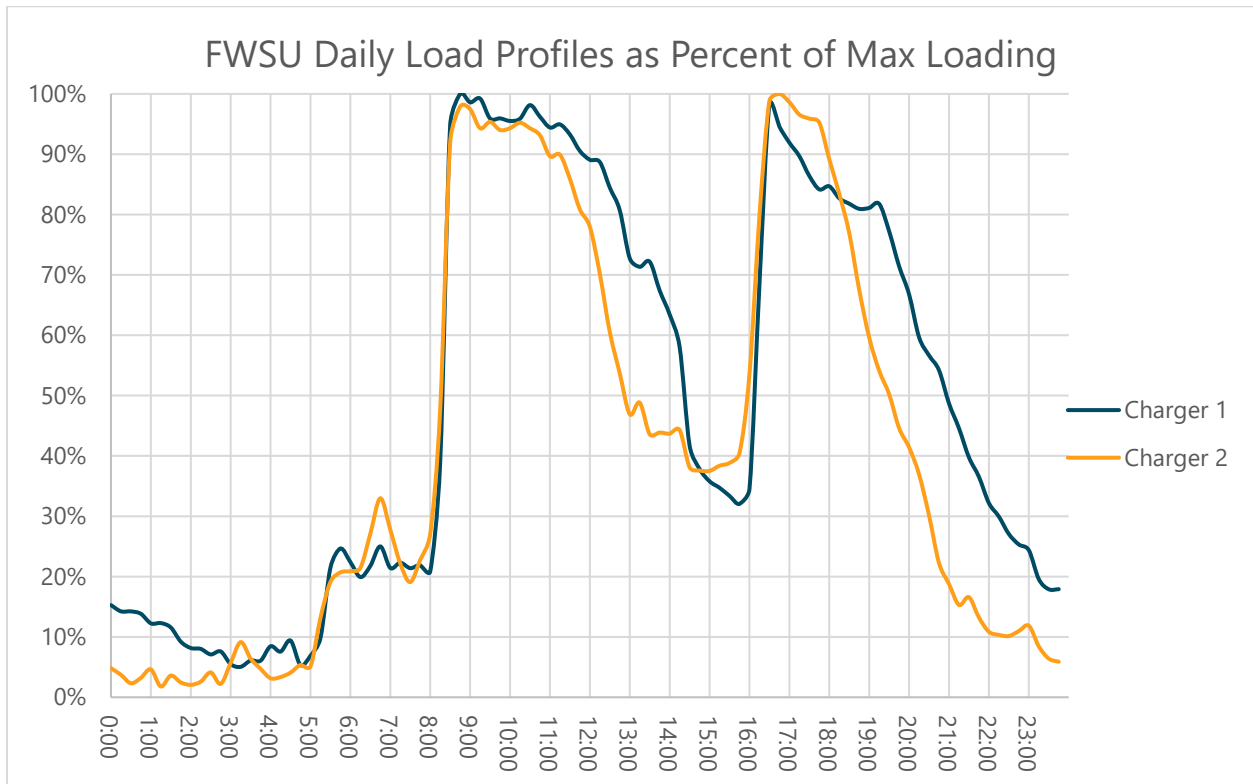
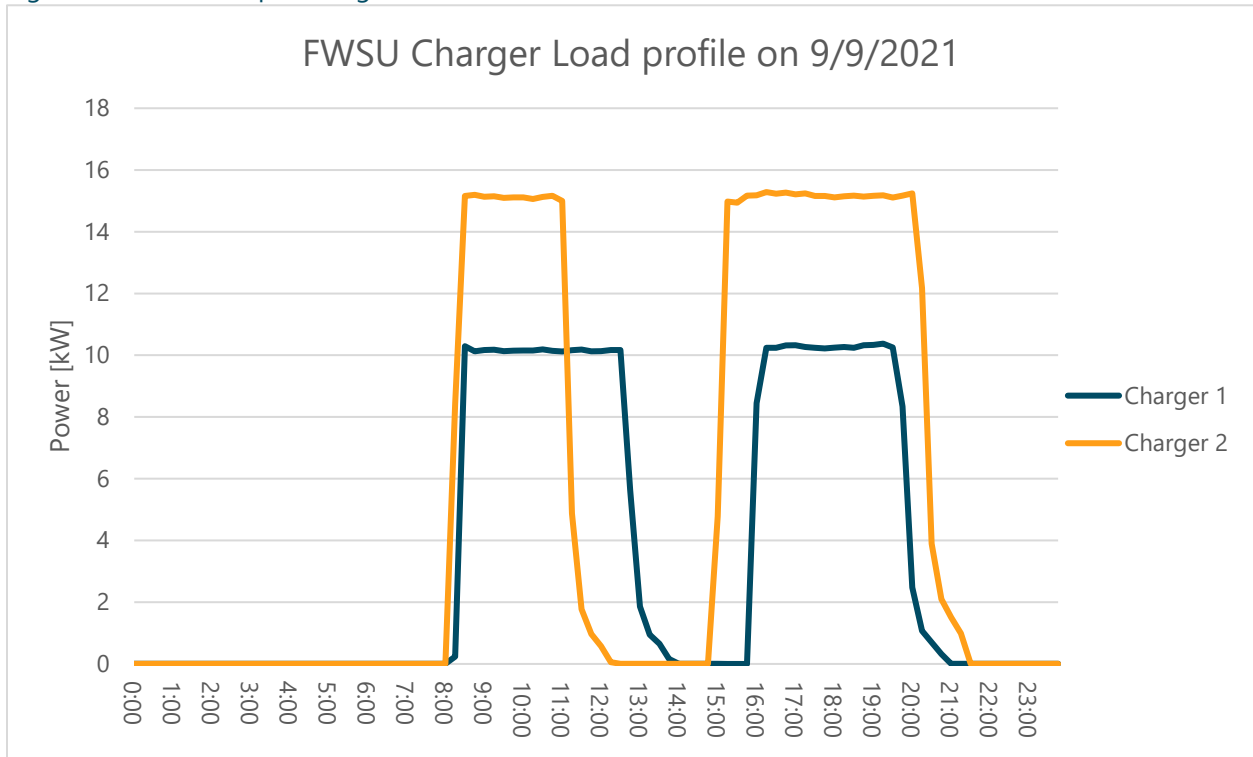

Figure 12 shows an actual snapshot of charger data from September 9, 2021. The 'tabletop' shape is quite typical of charger power draws. A loose fitting on one of the three power cables reduced the draw on Charger 1 until it was repaired a few months later.

Figure 12: FWSU Sample Charger Load Profile



Fuel Use and Emissions Reductions

The lack of data points during winter weather operations jeopardizes the accuracy of fuel use and emissions reductions data in the following tables. However, once normalized to a 10,000-mile standardized annual value, these findings align reasonably well to the values seen on the Lion buses at the other schools.

Table 18: Environmental Performance Metrics Bus 1981

Electric bus 1981 vs. scrapped diesel bus 3432		Electric bus 1981 vs. a new diesel bus	
Fuel gallons avoided [gal]	1,167	Fuel gallons avoided [gal]	1,167
NOx reduction [lbs]	153.8	NOx reduction [lbs]	18.3
PM2.5 reduction [lbs]	9.9	PM2.5 reduction [lbs]	0.1
PM10 reduction [lbs]	11.0	PM10 reduction [lbs]	0.1
GHG reduction [short tons]	10.1	GHG reduction [short tons]	10.1

Table 19: Environmental Performance Metrics Bus 1982

Electric bus 1982 vs. scrapped diesel bus 6663		Electric bus 1982 vs. a new diesel bus	
Fuel gallons avoided [gal]	1,220	Fuel gallons avoided [gal]	1,220
NOx reduction [lbs]	154.3	NOx reduction [lbs]	18.4
PM2.5 reduction [lbs]	9.9	PM2.5 reduction [lbs]	0.1
PM10 reduction [lbs]	11.0	PM10 reduction [lbs]	0.2
GHG reduction [short tons]	10.4	GHG reduction [short tons]	10.4

The enhanced emissions reductions numbers seen in Tables 18 and 19 are primarily due to more stringent EPA regulations adopted in 2007. The two scrapped FWSU buses were manufactured in 2004 (Bus 6663) and 2005 (Bus 3432), before the EPA tightened emissions standards for NOx and particulate matter (PM, 2.5 µm and 10 µm). This changed regulatory framework explains the difference in emissions reductions between scrapped diesel buses and new diesel buses.

Adding diesel fired auxiliary heaters to heat the cabin and minimize the range impacts of relying on bus batteries for heat increased NOx emissions. Comparing an electric bus to a new diesel, these emissions are almost ten times less than when the comparison is against the older scrapped vehicles. Particulate matter emissions from diesel auxiliary heaters in electric buses are nearly the same the particulate matter emissions from a new diesel school bus because the heaters are subject to less stringent regulations.

Maintenance and Reliability (in brief)

The maintenance and reliability of FWSU’s Blue Bird buses were critical issues, both for this pilot study and for the school district more generally. Bus 1981 had a 57% in-service rate and Bus 1982 had a 29% in-service rate during the study period. Both buses spent the large majority of January, February, and March off the road for each of two years due to major drivetrain, charger, and thermal management issues. While the winter months saw the most issues, the other months weren't issue-free, with second-year issues continuing right up and into the summer period. A full list of maintenance issues can be found in [Appendix C](#). Based solely on these first two years of performance, these Blue Bird buses do not appear to be viable student transportation options, especially in winter months. However, two is a very small sample size and a larger sample size would be needed to make a broader determination.

Not captured in the reliability numbers is that these vehicles arrived with several issues that had to be addressed before they could be put into operation. All of the buses in this pilot required some alterations or fixes upon delivery prior to being put into service, but the Blue Bird buses required more than most, as seen in [Appendix C](#). These included: incorrect paint colors, bent compartment doors, compressed air leaks, missing tow hooks, missing dust shield, a driver seat bolt issue, and a missing coolant vent hose. Within the first month, water penetrated into an electrical compartment, the 12VDC system depleted repeatedly, the e-brake needed to be adjusted, and a hood had to be replaced. While these early issues did not prevent the buses from being deployed by the time school started in September, by the December 2021 holiday break both buses experienced drivetrain and thermal management issues that resulted in the buses being inoperable.

Over the 20-month evaluation period, drivers occasionally experienced the sudden onset of issues enroute, such as critical drivetrain faults and electrical alarms, and drivers reported that they were hesitant to drive the electric buses out of fear of being stranded with pupils on board. The two buses experienced sixty-one separate issues over the two-year pilot. For comparison, over a 12-month span, CVSD's two buses experienced 14 mechanical issues and BUUSD/STA two buses experienced 4. The second winter for FWSU saw longer extended outages while the buses were being serviced, and issues have persisted up to the publication of this report. The school district is working with the dealer and repair facility to find a long-term solution.



Photo Credit: Tom Fisher, VEIC

Summary of Electric Transit Bus Findings

- **Top Findings**
- **Marble Valley Regional Transit District Evaluation**

Top Findings

Transit buses are clearly viable for use in Vermont. Despite some hiccups here and there, these two buses are well-received and are actively and effectively serving the public today. As an indication of their success, MVRTD is proactively engaged in plans to make use of federally available monies to procure several more electric buses for deployment in the Rutland region.

Despite the mixed first-year in-service rates on these buses (59% on Bus 3555 and 89% on Bus 3556), MVRTD is generally pleased with how well the buses are performing. Some of the service days lost can be attributed to the district learning how best to handle non-critical faults or alarm lights. Much of the lost service is also due to unusually long delivery times for replacement parts.

The rollout of electric buses with transit agencies is markedly different, and in many ways easier than it has been with school buses. With more staff and funding available to give the transit buses additional attention, additional training for drivers and mechanics, and the heightened service provided to transit agencies by specialized vendors, issues that crop up are more quickly diagnosed and resolved. Downtime is also more easily handled as there are generally more 'spares' available for use if needed.

Charger maintenance has been a constant issue. Partially due to some delivery challenges and temporary solutions, the district has experienced several critical failures on their two 50 kW ABB chargers. Some, less critical, are still ongoing. Further, MVRTD has not been happy with the level of service available on this front and will be seeking alternative equipment manufacturers with their next round of charger procurements.

Fortunately, the chargers purchased are of sufficient power to allow the buses to take turns on a single charger for a period, if needed. Having the flexibility to reduce the route miles the vehicles are driven, and thus the energy demands on the chargers, has also aided in handling prolonged charger faults. Adding additional chargers will further alleviate this weak point, and plans are also in place to procure a mobile charger should a bus require a charge while on route.

The ranges that the transit buses were able to achieve during this pilot were a pleasant surprise. The two 35-foot low-floor Gillig buses have a nominal range of 150 miles according to the manufacturer, a figure backed up by Altoona Testing (a nationally recognized standard in performance testing conducted by the Larson Transportation Institute's Bus Research and Testing Center, located in Altoona, Pennsylvania). In this pilot, the average real-world ranges across all seasons were found to be 160 Miles on Bus 3555 and 159 miles on Bus 3556.

With fuel economy being so low on standard diesel transit buses (~4 MPG) as well as the greater number of miles put on the transit buses as compared to the school buses, transit buses delivered higher return on investment. While electric transit buses are considerably more expensive than electric school buses, the worst performing transit bus saved more in fuel costs in its first year than all six school buses combined. Likewise, the same worst performing transit bus saved roughly as much greenhouse gas emissions as the top three school buses combined.

Marble Valley Regional Transit District Evaluation

Fleet Characterization

Location

The Marble Valley Regional Transit District provides transit service to much of central, western Vermont. Headquartered in Rutland, VT, the bulk of the district's operations are in the Rutland city area with connector routes that extend to towns north, south, east, and west of Rutland. Middlebury to the north and Manchester to the south are each a little over 30 miles away. Fair Haven to the west and Killington Ski Resort to the east are each roughly 20 miles distant.

Terrain and routes

The majority of the driving in the city of Rutland and to and from nearby towns is on fairly flat, paved road, with only about 200 feet of max elevation change. However, the buses were occasionally put on the route that runs to Killington Ski Resort which sits at an elevation approximately 2,000 feet higher than the bus depot in Rutland. On those days, the buses covered a 76-mile round trip and used roughly 75% of the buses' battery, including a few trips in cooler November for the Killington World Cup event. However, the bulk of the bus travel split evenly between the three routes shown below in Figures 13, 14, and 15. The first is an in-town route, the second a loop through a couple nearby towns, and the third a longer Middlebury connector route. With the electric buses being a bit heavier than their diesel counterparts, MVRTD made a point to avoid unpaved roads and parking lots during mud season.

Figure 13: MVRTD Route Map 1

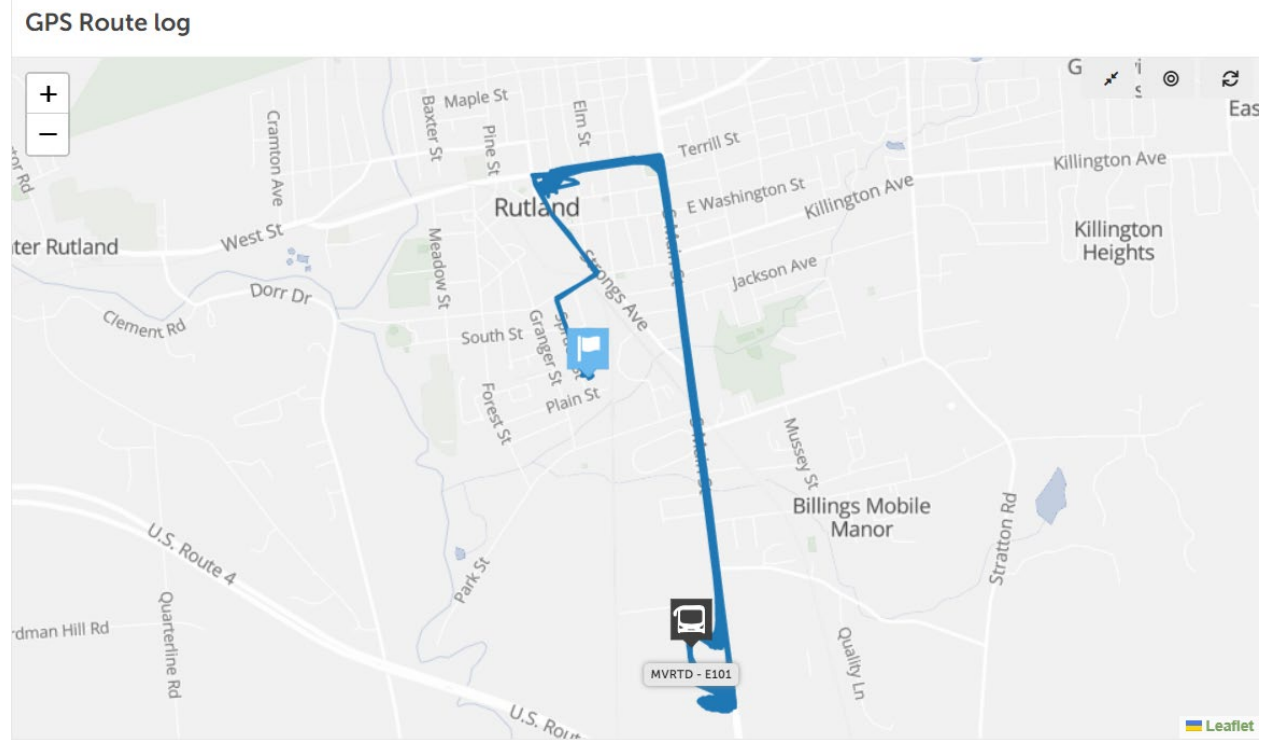

Figure 14: MVRTD Route Map 2

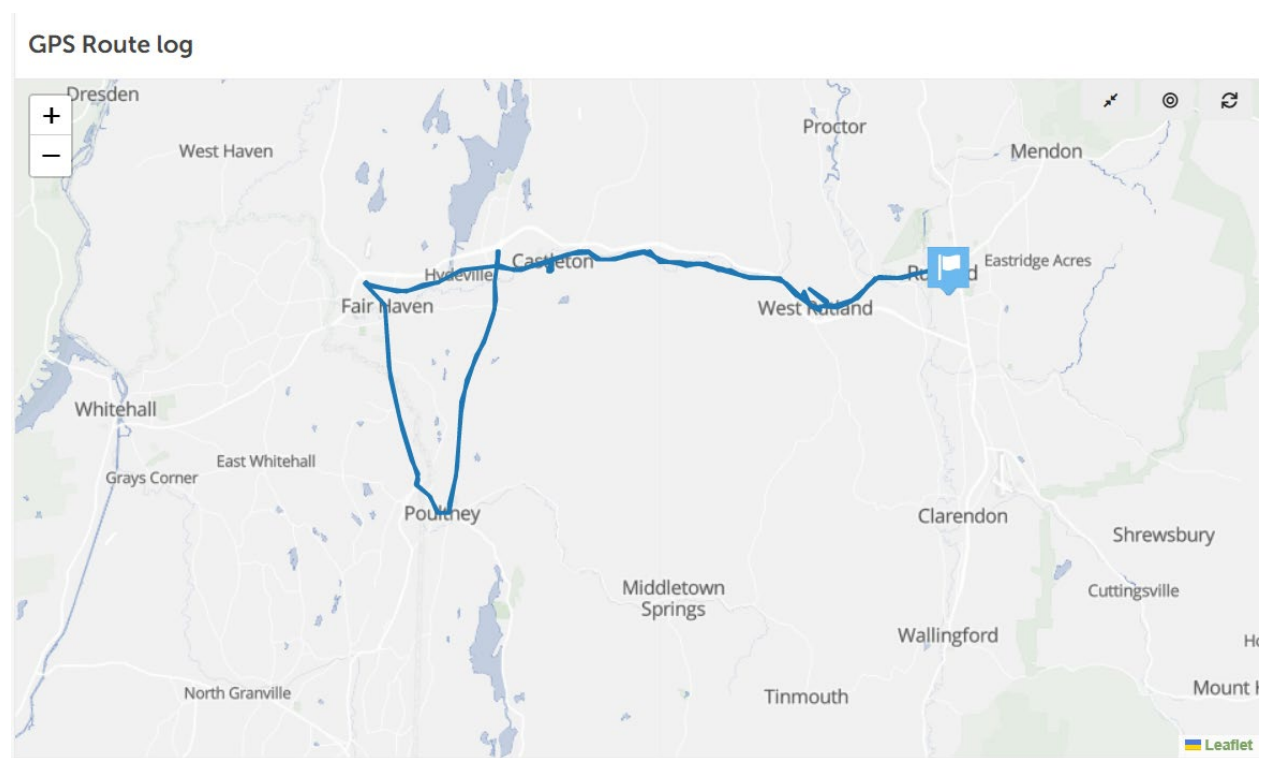
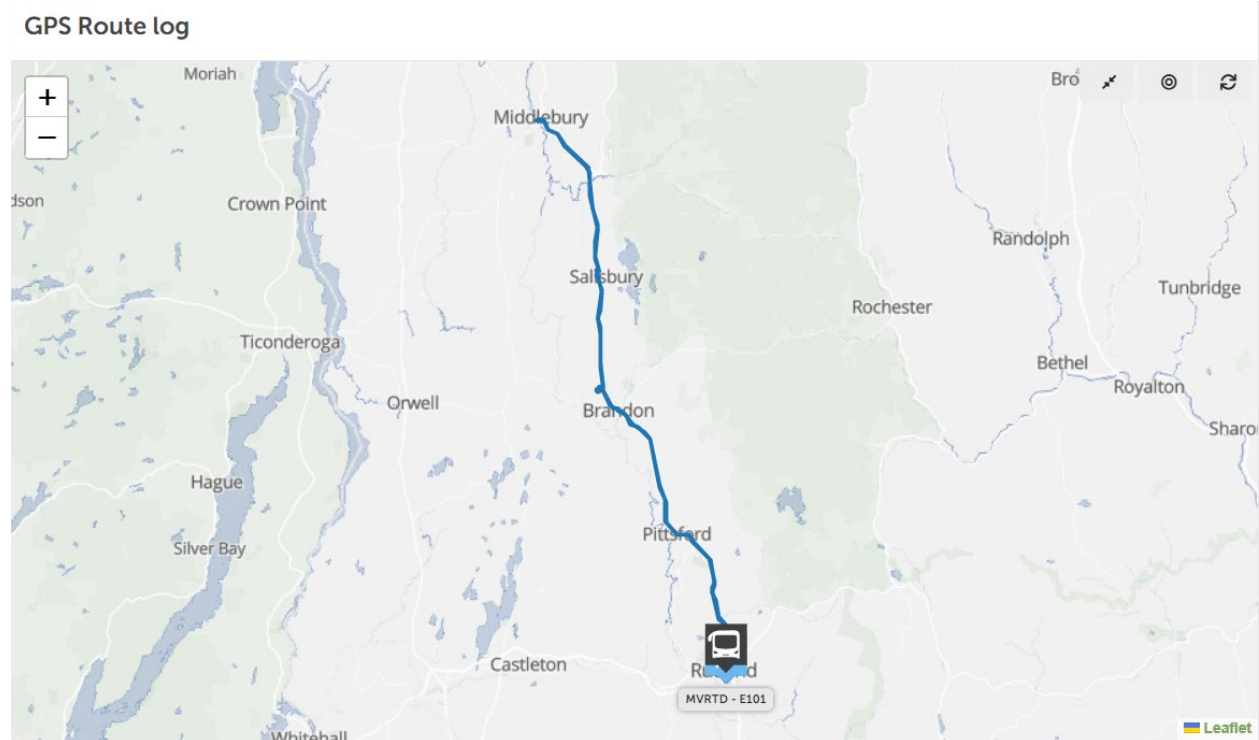

Figure 15: MVRTD Route Map 3



Charging Sites

The primary bus depot for MVRTD is in Rutland and occupies property on either side of Spruce Street. The transit district is currently constructing a new office building on the west side of the road and a new bus barn on the east side. As part of that larger plan, MVRTD decided to install one charger on each side of the road and use separate electrical service for each. The future bus barn will be EV-ready with new chargers, and several additional electric buses planned over the next couple years. For this pilot, MVRTD procured two 50kW DC fast charging ABB chargers through a managed charging contractor, OpConnect. Due to global pandemic induced equipment shortages, a Canadian source procured the chargers, which led to some interoperability issues and delayed servicing for charger maintenance. Regardless of these issues, the chargers had sufficient power to keep the buses in operation for the entire pilot evaluation period. Once the charging issues are sorted and/or additional chargers are added, MVRTD expects to expand the distances the buses are utilized each day.

Image 5: Charging configuration at MVRTD

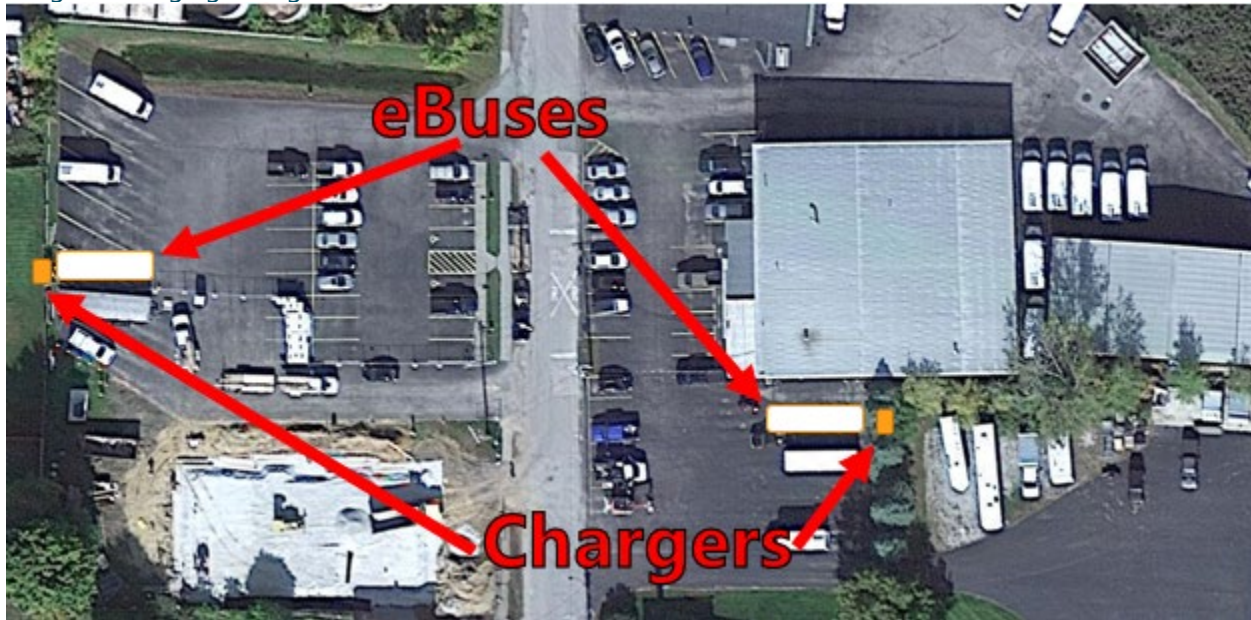

Weather

As transit buses, the MVRTD electric Gilligs run mostly during daylight hours and experience average route temperatures slightly higher than school buses which travel exclusively in the morning and afternoon. These are also sufficiently more complicated vehicles, which makes it difficult to compare them with school buses. That said, a familiar pattern emerged in the transit bus data.

Figure 16 shows that ambient temperature affected nominal range. Only a few data points were captured on the colder end of the spectrum. Interestingly, the vehicles appear to have reached their nominal 150 miles of range at ambient temperatures near 45 degrees Fahrenheit. As temperatures rose above 45 degrees Fahrenheit, the buses regularly achieved real-world ranges higher than the nominal 150 miles, often reaching more than 200 miles of range. The linear regressions indicate that the buses generally lost a little less than 1% of range for each degree Fahrenheit of daytime daily average temperature drop.

Figure 16: MVRTD Bus Ranges vs. Ambient Temperature

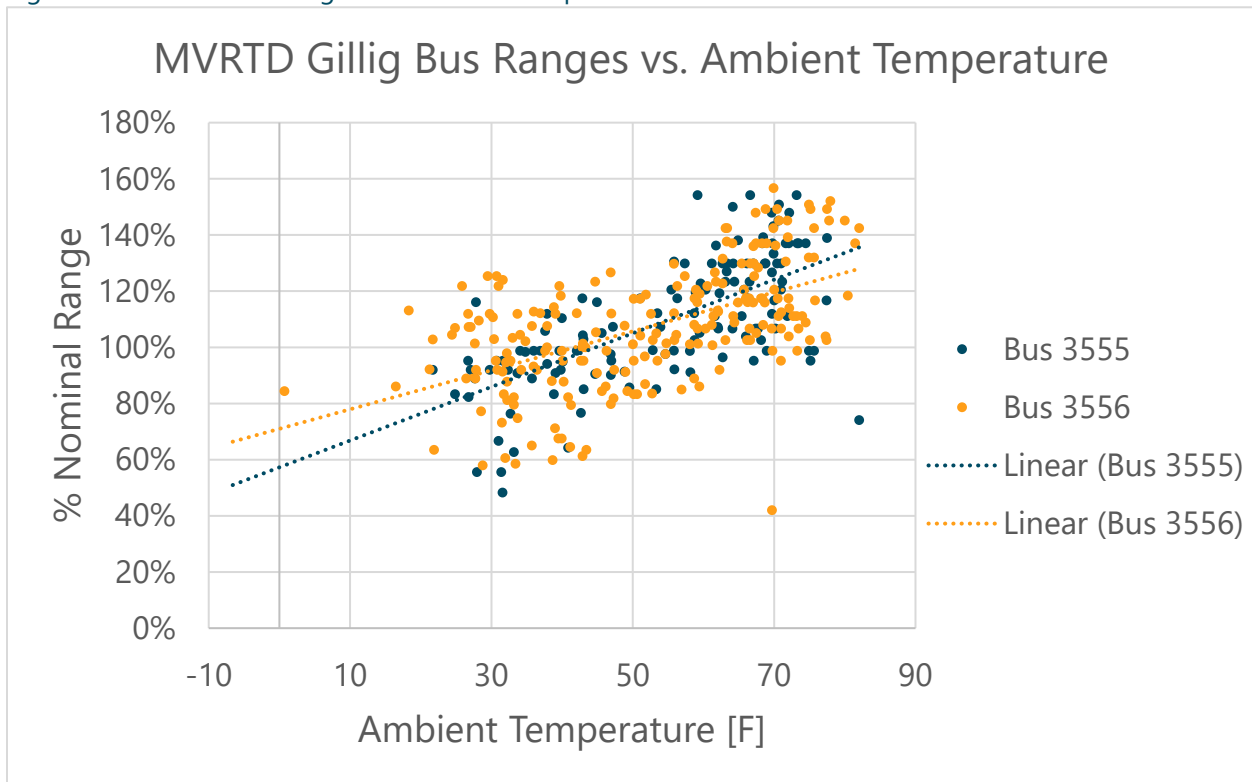

Fuel Cost Savings

Without another transit agency to compare against, no normalization was performed on the data in the table below. However, the team included miles travelled to make it easier to interpolate findings to other sites. As Table 20 shows, switching to electric transit buses should save the district roughly \$11,500 per year per bus in fuel savings. That figure should increase as the buses become more heavily utilized, as MVRTD has stated that it plans to do. Additionally, as the fleet transitions onto a managed charging plan and switches to a time-of-use utility rate, the district could potentially see another 15% in operational savings thanks to lower electric rates.

Table 20: MVRTD Fuel Cost and Consumption Savings

	Miles travelled [mi]	Baseline diesel avoided [gal]	Energy consumed [MWh]	Aux. heater diesel consumed [gal]	Diesel fuel cost avoided [\$]	Electric fuel costs [\$]	Diesel fuel costs [\$]	Total fuel savings [\$]
MVRTD - Gillig Bus 3555	11,244	2,556	25.8	236.3	\$13,872	\$4,421	\$1,190	\$8,261
MVRTD - Gillig Bus 3556	18,840	4,282	43.7	171.4	\$23,282	\$7,488	\$873	\$14,921

Vehicle Efficiency

The two electric transit buses saw remarkably similar annual operational efficiencies, hovering on either side of 2.3 kWh/mi. At first glance, this would appear to perfectly match the 2.3 kWh/mi figure conservatively advertised by Gillig. However, Gillig's number is on-road efficiency while this study's findings are for operational efficiency. Operational efficiency should be higher than on-road, as it also accounts for charger losses and power consumption while idled. Thus, these results show Gillig's buses to be more efficient than advertised. This finding makes sense given the better-than-expected ranges in warm temperatures (Figure 16).

Converting 2.3 kWh/mi operational efficiency to MPG (miles per gallon), equates to approximately 15 MPGe (miles per gallon equivalent). Fuel economy for a typical diesel transit bus is approximately 4.4 MPG.

Electric Load Profiles

As Figure 17 shows, MVRTD tends to charge its buses twice a day, once in the morning and once in the evening. Throughout the pilot period, the Public Utility Commission temporarily excluded the district from the typical electric rate tariff rules and allowed it to stay on a flat rate. Once this exclusion expires on July 31st, 2023, the district will likely elect to engage their managed charging contractor and push all charging into the off-peak hours of 11pm to 6am. This will save the district 15-20 % on their electric bills, as the off-peak rate is less than the current flat rate.

Figure 17: MVRTD Daily Load Profiles as Percent of Max Loading

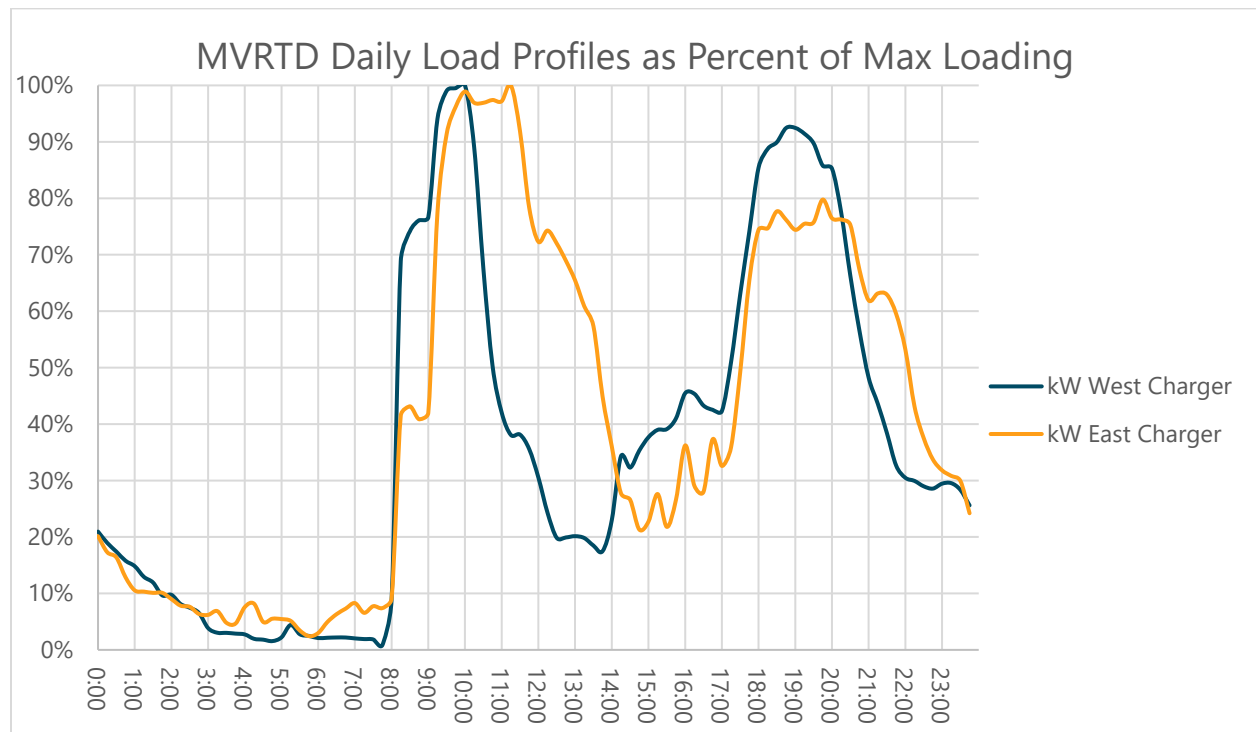

Fuel Use and Emissions Reductions

Relying on values derived from the Argonne National Lab’s AFLEET tool, the team utilized miles traveled, electricity used, and consumption of heater diesel gallons to calculate the environmental impacts of electrifying the MVRTD buses. As baseline comparators, the team used a new diesel transit bus and the actual bus scrapped as part of this pilot. Tables 21 and 22 indicate the first-year emissions and fuel use reductions.

Table 21: Environmental Performance of Bus 3555

Electric bus 3555 vs. scrapped diesel bus 1626		Electric bus 3555 vs. a new diesel bus	
Fuel gallons avoided [gal]	2,319	Fuel gallons avoided [gal]	2,319
NOx reduction [lbs]	127.5	NOx reduction [lbs]	41.8
PM2.5 reduction [lbs]	0.5	PM2.5 reduction [lbs]	0.0
PM10 reduction [lbs]	0.6	PM10 reduction [lbs]	0.0
GHG reduction [short tons]	25.6	GHG reduction [short tons]	25.6

Table 22: Environmental Performance of Bus 3556

Electric bus 3556 vs. scrapped diesel bus 1627		Electric bus 3556 vs. a new diesel bus	
Fuel gallons avoided [gal]	4,110	Fuel gallons avoided [gal]	4,110
NOx reduction [lbs]	214.0	NOx reduction [lbs]	70.3
PM2.5 reduction [lbs]	0.9	PM2.5 reduction [lbs]	0.0
PM10 reduction [lbs]	1.0	PM10 reduction [lbs]	0.0
GHG reduction [short tons]	45.3	GHG reduction [short tons]	45.3

Comparing the columns on the left with those on the right shows the effect of stricter emissions standards adopted by the EPA through the mid-to-late 2000s. Nitrogen Oxides (NOx) and Particulate Matter (PM, 2.5 µm and 10 µm) show significantly higher reductions compared with scrapped buses manufactured in 2008 than compared with new diesel buses. Additionally, while waste heat from the engine provides cabin heat on diesel buses, electric buses must be heated either with electricity, which reduces the energy available to the drivetrain and thus reduces range, or with diesel fired auxiliary heaters. Given Vermont’s cold climate, the district opted to use auxiliary diesel heaters which have much less stringent emissions requirements than diesel engines.

The result is that a couple year difference in age of the scrappage vehicle, combined with less NOx and PM capture at the source for the heating system, create an outsized impact on the emissions findings. With no realistic way to capture these emissions at the tailpipe, the level of greenhouse gas emissions (GHG) is a direct function of the amount of diesel burned for auxiliary heat. Thus, GHG emissions reductions are the same whether compared to a new diesel bus or an older scrapped diesel bus. NOx emission reductions are decreased by two-thirds when the baseline switches from the scrapped bus to a new diesel. And particulate matter reductions are practically eliminated when

comparing an electric bus against a new diesel if the electric is heated using a diesel auxiliary heater.¹⁰

Maintenance and Reliability (in brief)



Over the course of the one-year pilot, Bus 3555 achieved a 59% in-service rate and Bus 3556 achieved an 89% in-service rate (days actually in service divided by the number of days expected to be in service). As Table 23 shows, Bus 3555 lost a significant number of days due to parts delays. While much of this might be attributed to ongoing Covid-related global and national supply-chain issues, some of the blame must be placed on the newness and thus scarcity of the electric vehicle specific parts.

¹⁰ This study did not evaluate cabin air quality. At this stage of technological development, it is prudent to add an auxiliary diesel heater to reduce the draw off the batteries during cold weather in northern climates. While eliminating drivetrain emissions should reduce air pollutants in and around the vehicle, the auxiliary heaters are less well-regulated than vehicle drivetrains and, without specific data, this report does not attempt to indicate either an improvement or degradation of air quality for riders.

Table 23: Days of Lost Service by Category

	Bus 3555	Bus 3556
Parts Back Order	55	0
High-voltage system	20	0
Thermal Management	16	0
Battery Recall	7	8
Preventative	3	9
Training	6	2
Unknown Fault	3	4
Anti-lock Braking	0	5
Steering Sensor	4	0
EVSE	3	1
Driver shortage	2	2
Weather	1	1
Software Update	0	1

Appendices

- Appendix A: Data Tables
- Appendix B: Loadshapes, Phantom Loading, and the Value of Sub-metering
- Appendix C: Details on School Bus Maintenance Issues
- Appendix D: Project Partner Selection RFQ and RFP
- Appendix E: Project Partner Agreements
- Appendix F: Procurement RFPs
- Appendix G: Sample Data Collection Plan
- Appendix H: Summary of Media Reports

Appendix A: Data Tables

BUUSD/STA - Lion Bus 8019	May-22	Jun-22	Jul-22	Aug-22	Sep-22	Oct-22	Nov-22	Dec-22	Jan-23	Feb-23	Mar-23	Apr-23	Total
In-service rate [%]	71%	0%	100%	100%	86%	72%	0%	40%	89%	94%	39%	67%	60%
Mileage [mi]	647	0	0	107	631	587	-	186	633	604	204	391	3,991
Real world range [mi]	82.8	-	-	81.3	79.3	82.1	-	55.9	73.4	59.7	65.3	80.5	74.2
Average daily mileage [mi]	43.1	-	0.0	35.6	35.1	45.2	-	31.0	37.3	35.6	28.0	39.1	37.2
Energy consumed [kWh]	1,213	358	12	249	1,674	1,418	315	751	1,498	1,511	762	931	10,692
Diesel consumed [gal]	2.7	0.0	0.0	0.0	0.0	0.0	0.0	5.6	10.5	19.9	0.0	9.4	48.1
Efficiency [kWh/mi]	1.9	2.2	-	2.1	2.2	2.0	-	2.0	2.2	2.4	2.1	1.7	2.1
Fuel gallons avoided [gal]	78.9	0.0	0.0	13.0	77.0	71.6	0.0	22.7	77.2	73.7	24.9	47.6	486.7
Diesel fuel costs avoided [\$]	\$481	\$0	\$0	\$71	\$397	\$349	\$0	\$128	\$396	\$377	\$118	\$218	\$2,535
Electricity costs [\$]	\$208	\$61	\$2	\$43	\$287	\$243	\$54	\$129	\$257	\$259	\$131	\$160	\$1,833
Aux heater diesel fuel costs [\$]	\$16	\$0	\$0	\$0	\$0	\$0	\$0	\$32	\$54	\$102	\$0	\$43	\$247
Fuel savings [\$]	\$257	-\$61	-\$2	\$28	\$110	\$106	-\$54	-\$33	\$85	\$17	-\$13	\$16	\$456
NOx reduction vs scrapped [lbs]	5.1	0.0	0.0	0.8	5.0	4.7	0.0	1.5	5.0	4.8	1.6	3.1	31.7
PM2.5 reduction vs. scrapped [lbs]	0.0	0.0	0.0	0.0	0.0	0.0	0.0	0.0	0.0	0.0	0.0	0.0	0.1
PM10 reduction vs. scrapped [lbs]	1.3	0.0	0.0	0.2	1.3	1.2	0.0	0.4	1.3	1.2	0.4	0.8	7.9
GHG reduction vs scrapped [short tons]	0.7	-0.1	0.0	0.1	0.6	0.6	-0.1	0.1	0.5	0.4	0.1	0.3	3.3
NOx reduction vs new diesel [lbs]	1.2	0.0	0.0	0.2	1.2	1.1	0.0	0.3	1.1	1.1	0.4	0.7	7.3
PM2.5 reduction vs. new diesel [lbs]	0.0	0.0	0.0	0.0	0.0	0.0	0.0	0.0	0.0	0.0	0.0	0.0	0.0
PM10 reduction vs. new diesel [lbs]	0.0	0.0	0.0	0.0	0.0	0.0	0.0	0.0	0.0	0.0	0.0	0.0	0.0
GHG reduction vs new diesel [short tons]	0.7	-0.1	0.0	0.1	0.6	0.6	-0.1	0.1	0.5	0.4	0.1	0.3	3.3

BUUSD/STA - Lion Bus 8058	May-22	Jun-22	Jul-22	Aug-22	Sep-22	Oct-22	Nov-22	Dec-22	Jan-23	Feb-23	Mar-23	Apr-23	Total
In-service rate [%]	38%	100%	100%	87%	76%	100%	100%	93%	95%	94%	78%	100%	86%
Mileage [mi]	278	507	0	0	560	685	664	472	668	653	425	530	5,443
Real world range [mi]	75.2	85.1	-	-	82.3	82.7	75.2	73.2	75.6	72.0	72.4	82.2	77.7
Average daily mileage [mi]	34.7	42.2	0.0	0.0	35.0	38.1	39.1	33.7	37.1	38.4	30.4	35.3	32.0
Energy consumed [kWh]	603	1,124	10	93	911	1,406	1,194	1,316	1,874	1,678	1,298	1,168	12,674
Diesel consumed [gal]	0.2	0.0	0.0	0.0	1.9	0.9	0.0	11.7	26.4	22.2	8.1	4.1	75.4
Efficiency [kWh/mi]	1.9	1.9	-	-	2.0	2.0	1.9	2.4	2.0	2.3	2.0	1.8	2.0
Fuel gallons avoided [gal]	33.9	61.9	0.0	0.0	68.3	83.6	81.0	57.6	81.5	79.7	51.8	64.6	663.8
Diesel fuel costs avoided [\$]	\$207	\$384	\$0	\$0	\$353	\$407	\$483	\$324	\$417	\$408	\$246	\$296	\$3,524
Electricity costs [\$]	\$103	\$193	\$2	\$16	\$156	\$241	\$205	\$226	\$321	\$288	\$222	\$200	\$2,172
Aux heater diesel fuel costs [\$]	\$1	\$0	\$0	\$0	\$10	\$4	\$0	\$66	\$135	\$114	\$38	\$19	\$387
Fuel savings [\$]	\$102	\$191	-\$2	-\$16	\$187	\$162	\$279	\$33	-\$39	\$7	-\$15	\$77	\$965
NOx reduction vs scrapped [lbs]	2.2	4.0	0.0	0.0	4.5	5.5	5.3	3.7	5.3	5.2	3.4	4.2	43.2
PM2.5 reduction vs. scrapped [lbs]	0.0	0.0	0.0	0.0	0.0	0.0	0.0	0.0	0.0	0.0	0.0	0.0	0.2
PM10 reduction vs. scrapped [lbs]	0.6	1.0	0.0	0.0	1.1	1.4	1.3	0.9	1.3	1.3	0.8	1.1	10.8
GHG reduction vs scrapped [short tons]	0.3	0.6	0.0	0.0	0.7	0.8	0.8	0.3	0.3	0.4	0.3	0.5	4.9
NOx reduction vs new diesel [lbs]	0.5	0.9	0.0	0.0	1.0	1.3	1.2	0.9	1.2	1.2	0.8	1.0	9.9
PM2.5 reduction vs. new diesel [lbs]	0.0	0.0	0.0	0.0	0.0	0.0	0.0	0.0	0.0	0.0	0.0	0.0	0.0
PM10 reduction vs. new diesel [lbs]	0.0	0.0	0.0	0.0	0.0	0.0	0.0	0.0	0.0	0.0	0.0	0.0	0.1
GHG reduction vs new diesel [short tons]	0.3	0.6	0.0	0.0	0.7	0.8	0.8	0.3	0.3	0.4	0.3	0.5	4.9

CVSD - Lion Bus 8020	Sep-21	Oct-21	Nov-21	Dec-21	Jan-22	Feb-22	Mar-22	Apr-22	May-22	Jun-22	Jul-22	Aug-22	Total
In-service rate [%]	85%	100%	100%	100%	79%	15%	22%	13%	100%	100%	100%	100%	73%
Mileage [mi]	1,157	1,388	1,227	1,442	1,159	101	397	69	1,710	872	350	115	9,988
Real world range [mi]	97.9	97.9	88.2	81.1	75.3	51.3	74.2	125.4	132.1	130.8	145.7	126.3	101.3
Average daily mileage [mi]	67.8	73.1	72.2	88.9	77.3	45.3	78.9	32.8	85.0	78.1	49.9	97.0	75.0
Energy consumed [kWh]	2,091	2,308	2,180	2,436	2,286	322	798	24	2,366	1,284	369	163	16,629
Diesel consumed [gal]	3.8	7.5	5.7	13.6	22.9	8.3	26.8	0.0	0.0	0.0	0.0	0.0	88.5
Efficiency [kWh/mi]	1.6	1.6	1.6	1.6	1.8	2.1	1.7	3.7	1.5	1.5	2.2	2.0	1.7
Fuel gallons avoided [gal]	141.1	169.3	149.6	175.9	141.3	12.4	48.4	8.5	208.5	106.4	42.7	14.1	1,218.1
Diesel fuel costs avoided [\$]	\$464	\$565	\$546	\$642	\$512	\$49	\$233	\$45	\$1,272	\$660	\$253	\$77	\$5,317
Electricity costs [\$]	\$358	\$396	\$374	\$418	\$392	\$55	\$137	\$4	\$406	\$220	\$63	\$28	\$2,850
Aux heater diesel fuel costs [\$]	\$12	\$25	\$21	\$50	\$83	\$33	\$129	\$0	\$0	\$0	\$0	\$0	\$352
Fuel savings [\$]	\$93	\$145	\$152	\$175	\$37	-\$39	-\$33	\$41	\$867	\$440	\$190	\$49	\$2,114
NOx reduction vs scrapped [lbs]	17.8	21.3	18.9	22.2	17.8	1.5	6.1	1.1	26.3	13.4	5.4	1.8	153.5
PM2.5 reduction vs. scrapped [lbs]	1.1	1.4	1.2	1.4	1.1	0.1	0.4	0.1	1.7	0.9	0.3	0.1	9.9
PM10 reduction vs. scrapped [lbs]	1.3	1.5	1.4	1.6	1.3	0.1	0.4	0.1	1.9	1.0	0.4	0.1	11.0
GHG reduction vs scrapped [short tons]	1.3	1.6	1.4	1.6	1.1	0.0	0.2	0.1	2.2	1.1	0.5	0.1	11.3
NOx reduction vs new diesel [lbs]	2.1	2.5	2.2	2.6	2.1	0.2	0.7	0.1	3.1	1.6	0.6	0.2	18.2
PM2.5 reduction vs. new diesel [lbs]	0.0	0.0	0.0	0.0	0.0	0.0	0.0	0.0	0.0	0.0	0.0	0.0	0.1
PM10 reduction vs. new diesel [lbs]	0.0	0.0	0.0	0.0	0.0	0.0	0.0	0.0	0.0	0.0	0.0	0.0	0.1
GHG reduction vs new diesel [short tons]	1.3	1.6	1.4	1.6	1.1	0.0	0.2	0.1	2.2	1.1	0.5	0.1	11.3

CVSD - Lion Bus 8056	Sep-21	Oct-21	Nov-21	Dec-21	Jan-22	Feb-22	Mar-22	Apr-22	May-22	Jun-22	Jul-22	Aug-22	Total
In-service rate [%]	100%	100%	100%	100%	100%	100%	100%	100%	100%	100%	100%	100%	100%
Mileage [mi]	967	864	898	708	993	1,097	957	1,170	1,298	363	460	222	9,998
Real world range [mi]	99.6	97.9	92.2	93.8	75.9	77.9	97.9	102.9	104.2	101.5	101.7	81.9	94.5
Average daily mileage [mi]	48.4	45.5	52.8	44.3	49.6	81.5	41.6	73.1	64.9	40.4	28.8	30.3	50.8
Energy consumed [kWh]	1,212	1,282	1,694	1,601	2,266	2,146	1,744	1,769	1,868	566	568	365	17,081
Diesel consumed [gal]	14.4	0.0	0.0	0.0	13.7	11.3	0.0	13.0	15.1	0.0	0.0	0.0	67.5
Efficiency [kWh/mi]	1.7	1.5	1.7	1.9	2.2	1.8	1.9	1.5	1.4	1.7	2.0	2.3	1.8
Fuel gallons avoided [gal]	117.9	105.4	109.5	86.4	121.1	133.8	116.8	142.7	158.3	44.3	56.1	27.1	1,219.3
Diesel fuel costs avoided [\$]	\$388	\$352	\$400	\$315	\$438	\$529	\$563	\$753	\$966	\$275	\$332	\$148	\$5,458
Electricity costs [\$]	\$208	\$220	\$290	\$274	\$388	\$368	\$299	\$303	\$320	\$97	\$97	\$63	\$2,928
Aux heater diesel fuel costs [\$]	\$47	\$0	\$0	\$0	\$50	\$45	\$0	\$68	\$92	\$0	\$0	\$0	\$302
Fuel savings [\$]	\$133	\$132	\$109	\$41	\$0	\$116	\$264	\$382	\$553	\$178	\$235	\$85	\$2,228
NOx reduction vs scrapped [lbs]	14.9	13.3	13.9	10.9	15.3	16.9	14.8	18.0	20.0	5.6	7.1	3.4	154.2
PM2.5 reduction vs. scrapped [lbs]	1.0	0.9	0.9	0.7	1.0	1.1	0.9	1.2	1.3	0.4	0.5	0.2	9.9
PM10 reduction vs. scrapped [lbs]	1.1	1.0	1.0	0.8	1.1	1.2	1.1	1.3	1.4	0.4	0.5	0.2	11.0
GHG reduction vs scrapped [short tons]	1.1	1.1	1.1	0.8	0.9	1.1	1.1	1.3	1.5	0.5	0.6	0.3	11.5
NOx reduction vs new diesel [lbs]	1.8	1.6	1.6	1.3	1.8	2.0	1.8	2.1	2.4	0.7	0.8	0.4	18.3
PM2.5 reduction vs. new diesel [lbs]	0.0	0.0	0.0	0.0	0.0	0.0	0.0	0.0	0.0	0.0	0.0	0.0	0.1
PM10 reduction vs. new diesel [lbs]	0.0	0.0	0.0	0.0	0.0	0.0	0.0	0.0	0.0	0.0	0.0	0.0	0.1
GHG reduction vs new diesel [short tons]	1.1	1.1	1.1	0.8	0.9	1.1	1.1	1.3	1.5	0.5	0.6	0.3	11.5

FWSU - Blue Bird Bus 1981	Sep-21	Oct-21	Nov-21	Dec-21	Jan-22	Feb-22	Mar-22	Apr-22	May-22	Jun-22	Jul-22	Aug-22	Sep-22	Oct-22	Nov-22	Dec-22	Jan-23	Feb-23	Mar-23	Apr-23	Total
In-service Rate [%]	100%	85%	88%	88%	30%	0%	95%	88%	90%	83%	100%	50%	14%	80%	35%	75%	35%	0%	0%	33%	57%
Mileage [mi]	1,153	828	752	553	306	-	991	773	958	257	130	31	107	669	365	662	307	-	-	271	9,113
Real World Range [mi]	92.3	74.7	59.4	56.1	59.9	-	54.6	68.5	104.8	116.1	115.3	124.0	96.1	81.5	89.4	73.7	61.3	-	-	96.7	77.4
Average Daily Mileage [mi]	54.9	48.7	50.1	39.5	51.0	-	47.2	55.2	50.4	51.4	43.3	31.0	35.7	41.8	60.8	55.0	43.9	-	-	54.2	49.2
Energy Consumed [kWh]	2,123	1,930	2,138	1,783	1,121	4	2,880	1,869	1,573	723	342	160	331	1,357	766	761	686	0	192	-	20,740
Diesel Consumed [gal]	20.0	0.0	0.0	0.0	0.0	0.0	0.0	0.0	0.0	0.0	0.0	0.0	0.0	0.0	11.0	16.6	0.0	0.0	0.0	0.0	47.6
Efficiency [kWh/mi]	1.8	2.5	2.7	3.1	2.8	-	3.1	2.2	1.8	2.0	1.7	1.5	1.5	2.1	1.8	2.1	2.6	-	-	-	2.4
Fuel Gallons Not Consumed [gal]	140.6	101.0	91.7	67.4	37.3	-	120.9	94.3	116.8	31.3	15.9	3.8	13.0	81.6	44.5	80.7	37.4	-	-	33.0	1,111.3
Diesel Fuel Costs Avoided [\$]	\$463	\$337	\$335	\$246	\$135	\$0	\$583	\$498	\$713	\$194	\$94	\$21	\$67	\$397	\$266	\$455	\$192	\$0	\$0	\$151	\$5,146
Electricity Costs [\$]	\$364	\$331	\$366	\$306	\$192	\$1	\$494	\$320	\$270	\$124	\$59	\$27	\$57	\$233	\$131	\$130	\$118	\$0	\$33	\$0	\$3,555
Aux Heater Diesel Fuel Costs [\$]	\$66	\$0	\$0	\$0	\$0	\$0	\$0	\$0	\$0	\$0	\$0	\$0	\$0	\$0	\$66	\$93	\$0	\$0	\$0	\$0	\$225
Fuel Savings [\$]	\$33	\$7	-\$32	-\$59	-\$57	-\$1	\$89	\$177	\$443	\$70	\$35	-\$7	\$11	\$165	\$69	\$231	\$74	\$0	-\$33	\$151	\$1,366
NOX Reduction vs Scrapped [lbs]	17.7	12.7	11.6	8.5	4.7	0.0	15.2	11.9	14.7	4.0	2.0	0.5	1.6	10.3	5.6	10.2	4.7	0.0	0.0	4.2	140.1
PM2.5 Reduction vs. Scrapped [lbs]	1.1	0.8	0.7	0.5	0.3	0.0	1.0	0.8	1.0	0.3	0.1	0.0	0.1	0.7	0.4	0.7	0.3	0.0	0.0	0.3	9.0
PM10 Reduction vs. Scrapped [lbs]	1.3	0.9	0.8	0.6	0.3	0.0	1.1	0.9	1.1	0.3	0.1	0.0	0.1	0.7	0.4	0.7	0.3	0.0	0.0	0.3	10.0
GHG Reduction vs Scrapped [short tons]	1.1	0.9	0.7	0.5	0.2	0.0	0.9	0.8	1.2	0.2	0.1	0.0	0.1	0.8	0.3	0.7	0.3	0.0	-0.1	0.5	9.2
NOX Reduction vs New Diesel [lbs]	2.1	1.5	1.4	1.0	0.6	0.0	1.8	1.4	1.8	0.5	0.2	0.1	0.2	1.2	0.7	1.2	0.6	0.0	0.0	0.5	16.7
PM2.5 Reduction vs. New Diesel [lbs]	0.0	0.0	0.0	0.0	0.0	0.0	0.0	0.0	0.0	0.0	0.0	0.0	0.0	0.0	0.0	0.0	0.0	0.0	0.0	0.0	0.1
PM10 Reduction vs. New Diesel [lbs]	0.0	0.0	0.0	0.0	0.0	0.0	0.0	0.0	0.0	0.0	0.0	0.0	0.0	0.0	0.0	0.0	0.0	0.0	0.0	0.0	0.1
GHG Reduction vs New Diesel [short tons]	1.1	0.9	0.7	0.5	0.2	0.0	0.9	0.8	1.2	0.2	0.1	0.0	0.1	0.8	0.3	0.7	0.3	0.0	-0.1	0.5	9.2

FWSU - Blue Bird Bus 1982	Sep-21	Oct-21	Nov-21	Dec-21	Jan-22	Feb-22	Mar-22	Apr-22	May-22	Jun-22	Jul-22	Aug-22	Sep-22	Oct-22	Nov-22	Dec-22	Jan-23	Feb-23	Mar-23	Apr-23	Total
In-service Rate [%]	100%	55%	29%	0%	0%	0%	36%	56%	43%	14%	100%	100%	19%	0%	29%	63%	10%	6%	6%	0%	29%
Mileage [mi]	1,218	561	123	0	0	0	370	431	422	26	200	72	184	0	144	283	93	23	29	0	4,179
Real World Range [mi]	104.4	89.4	60.5	-	-	-	67.3	75.1	145.0	104.0	114.8	77.4	101.0	-	83.0	58.0	43.5	57.5	53.8	-	89.5
Average Daily Mileage [mi]	55.4	51.0	24.4	-	-	-	46.3	47.9	46.9	26.0	40.0	72.0	46.0	-	28.8	28.3	40.5	23.0	28.0	-	44.3
Energy Consumed [kWh]	2005	992	778	38	3	9	1052	959	836	23	351	317	229	61	393	1391	412	0	121	0	9968
Diesel Consumed [gal]	0.0	0.0	0.0	0.0	0.0	0.0	0.0	0.0	0.0	0.0	0.0	0.0	0.0	0.0	0.0	0.0	0.0	0.0	0.0	0.0	0.0
Efficiency [kWh/mi]	1.9	1.7	3.1	-	-	-	2.8	2.2	1.7	-	2.4	2.0	1.1	-	1.9	4.0	3.9	-	6.0	-	2.5
Fuel Gallons Not Consumed [gal]	148.5	68.4	15.0	0.0	0.0	0.0	45.1	52.6	51.5	3.2	24.4	8.8	22.4	0.0	17.6	34.5	11.3	2.8	3.5	0.0	509.6
Diesel Fuel Costs Avoided [\$]	\$489	\$229	\$55	\$0	\$0	\$0	\$217	\$278	\$314	\$20	\$144	\$48	\$116	\$0	\$105	\$194	\$58	\$14	\$17	\$0	\$2,297
Electricity Costs [\$]	\$344	\$170	\$133	\$7	\$1	\$1	\$180	\$164	\$143	\$4	\$60	\$54	\$39	\$10	\$67	\$238	\$71	\$0	\$21	\$0	\$1,709
Aux Heater Diesel Fuel Costs [\$]	\$0	\$0	\$0	\$0	\$0	\$0	\$0	\$0	\$0	\$0	\$0	\$0	\$0	\$0	\$0	\$0	\$0	\$0	\$0	\$0	\$0
Fuel Savings [\$]	\$145	\$58	-\$79	-\$7	-\$1	-\$1	\$37	\$113	\$171	\$16	\$84	-\$6	\$77	-\$10	\$38	-\$44	-\$13	\$14	-\$4	\$0	\$588
NOX Reduction vs Scrapped [lbs]	18.8	8.7	1.9	0.0	0.0	0.0	5.7	6.6	6.5	0.4	3.1	1.1	2.8	0.0	2.2	4.4	1.4	0.4	0.4	0.0	64.5
PM2.5 Reduction vs. Scrapped [lbs]	1.2	0.6	0.1	0.0	0.0	0.0	0.4	0.4	0.4	0.0	0.2	0.1	0.2	0.0	0.1	0.3	0.1	0.0	0.0	0.0	4.1
PM10 Reduction vs. Scrapped [lbs]	1.3	0.6	0.1	0.0	0.0	0.0	0.4	0.5	0.5	0.0	0.2	0.1	0.2	0.0	0.2	0.3	0.1	0.0	0.0	0.0	4.6
GHG Reduction vs Scrapped [short tons]	1.5	0.7	0.0	0.0	0.0	0.0	0.3	0.5	0.5	0.0	0.2	0.0	0.2	0.0	0.1	0.1	0.0	0.0	0.0	0.0	4.4
NOX Reduction vs New Diesel [lbs]	2.2	1.0	0.2	0.0	0.0	0.0	0.7	0.8	0.8	0.0	0.4	0.1	0.3	0.0	0.3	0.5	0.2	0.0	0.1	0.0	7.7
PM2.5 Reduction vs. New Diesel [lbs]	0.0	0.0	0.0	0.0	0.0	0.0	0.0	0.0	0.0	0.0	0.0	0.0	0.0	0.0	0.0	0.0	0.0	0.0	0.0	0.0	0.1
PM10 Reduction vs. New Diesel [lbs]	0.0	0.0	0.0	0.0	0.0	0.0	0.0	0.0	0.0	0.0	0.0	0.0	0.0	0.0	0.0	0.0	0.0	0.0	0.0	0.0	0.1
GHG Reduction vs New Diesel [short tons]	1.5	0.7	0.0	0.0	0.0	0.0	0.3	0.5	0.5	0.0	0.2	0.0	0.2	0.0	0.1	0.1	0.0	0.0	0.0	0.0	4.4

MVRTD - Gillig Bus 3555	May-22	Jun-22	Jul-22	Aug-22	Sep-22	Oct-22	Nov-22	Dec-22	Jan-23	Feb-23	Mar-23	Apr-23	Total
In-service rate [%]	100%	95%	55%	52%	65%	29%	9%	81%	76%	0%	65%	85%	59%
Mileage [mi]	1,259	1,661	800	856	983	531	114	1,309	1,256	-	1,077	1,398	11,244
Real world range [mi]	184.6	199.3	195.7	156.6	164.4	157.9	89.8	113.4	140.6	-	136.9	150.6	159.5
Average daily mileage [mi]	60.0	79.1	71.5	71.3	75.6	88.5	57.0	77.0	78.5	-	71.8	82.2	74.4
Energy consumed [kWh]	2,469	3,060	1,506	1,653	1,951	1,209	468	4,329	2,854	376	2,442	3,475	25,791
Diesel consumed [gal]	-	-	-	-	-	54	3	35	78	-	56	10	236
Efficiency [kWh/mi]	1.9	1.8	2.0	1.9	2.0	2.2	4.0	3.2	2.2	-	2.3	2.4	2.2
Fuel gallons avoided [gal]	286	378	182	195	223	121	26	298	285	-	245	318	2,556
Diesel fuel costs avoided [\$]	\$1,745	\$2,341	\$1,076	\$1,062	\$1,153	\$588	\$155	\$1,675	\$1,462	\$0	\$1,160	\$1,455	\$13,872
Electricity costs [\$]	\$423	\$525	\$258	\$283	\$334	\$207	\$80	\$742	\$489	\$64	\$419	\$596	\$4,421
Aux heater diesel fuel costs [\$]	\$0	\$0	\$0	\$0	\$0	\$264	\$17	\$195	\$401	\$0	\$266	\$46	\$1,190
Fuel savings [\$]	\$1,322	\$1,816	\$818	\$779	\$818	\$117	\$57	\$738	\$571	-\$64	\$476	\$814	\$8,261
NOx reduction vs scrapped [lbs]	14.3	18.9	9.1	9.7	11.2	6.0	1.3	14.8	14.2	0.0	12.2	15.9	127.5
PM2.5 reduction vs. scrapped [lbs]	0.1	0.1	0.0	0.0	0.1	0.0	0.0	0.1	0.0	0.0	0.0	0.1	0.5
PM10 reduction vs. scrapped [lbs]	0.1	0.1	0.0	0.0	0.1	0.0	0.0	0.1	0.0	0.0	0.0	0.1	0.6
GHG reduction vs scrapped [short tons]	3.3	4.4	2.1	2.2	2.5	0.7	0.2	2.6	2.3	-0.1	2.1	3.3	25.6
NOx reduction vs new diesel [lbs]	4.7	6.2	3.0	3.2	3.7	1.9	0.4	4.9	4.6	0.0	4.0	5.2	41.8
PM2.5 reduction vs. new diesel [lbs]	0.0	0.0	0.0	0.0	0.0	0.0	0.0	0.0	0.0	0.0	0.0	0.0	0.0
PM10 reduction vs. new diesel [lbs]	0.0	0.0	0.0	0.0	0.0	0.0	0.0	0.0	0.0	0.0	0.0	0.0	0.0
GHG reduction vs new diesel [short tons]	3.3	4.4	2.1	2.2	2.5	0.7	0.2	2.6	2.3	-0.1	2.1	3.3	25.6

MVRTD - Gillig Bus 3556	May-22	Jun-22	Jul-22	Aug-22	Sep-22	Oct-22	Nov-22	Dec-22	Jan-23	Feb-23	Mar-23	Apr-23	Total
In-service rate [%]	95%	95%	100%	100%	86%	62%	100%	71%	95%	75%	100%	86%	89%
Mileage [mi]	1,586	1,780	1,579	1,882	1,521	1,129	2,003	1,215	1,639	1,162	1,910	1,434	18,840
Real world range [mi]	169.2	171.1	189.0	193.9	181.9	143.1	118.2	133.9	161.8	139.1	155.8	142.3	159.2
Average daily mileage [mi]	83.5	84.8	79.0	78.4	84.5	86.8	80.1	81.0	82.0	77.5	83.0	79.7	81.6
Energy consumed [kWh]	3,123	3,293	3,010	3,686	2,860	2,750	6,136	4,181	4,022	3,132	4,423	3,068	43,684
Diesel consumed [gal]	-	0	-	-	-	27	8	18	58	33	-	27	171
Efficiency [kWh/mi]	1.9	1.8	1.9	1.9	1.9	2.4	3.1	3.4	2.4	2.5	2.3	2.1	2.3
Fuel gallons avoided [gal]	360	405	359	428	346	257	455	276	373	264	434	326	4,282
Diesel fuel costs avoided [\$]	\$2,199	\$2,508	\$2,124	\$2,335	\$1,784	\$1,250	\$2,718	\$1,555	\$1,907	\$1,352	\$2,058	\$1,493	\$23,282
Electricity costs [\$]	\$535	\$564	\$516	\$632	\$490	\$471	\$1,052	\$717	\$689	\$537	\$758	\$526	\$7,488
Aux heater diesel fuel costs [\$]	\$0	\$1	\$0	\$0	\$0	\$131	\$50	\$102	\$295	\$171	\$0	\$122	\$873
Fuel savings [\$]	\$1,663	\$1,942	\$1,609	\$1,704	\$1,293	\$647	\$1,616	\$736	\$922	\$644	\$1,299	\$845	\$14,921
NOx reduction vs scrapped [lbs]	18.0	20.2	18.0	21.4	17.3	12.8	22.8	13.8	18.6	13.2	21.7	16.3	214.0
PM2.5 reduction vs. scrapped [lbs]	0.1	0.1	0.1	0.1	0.1	0.0	0.1	0.1	0.1	0.0	0.1	0.1	0.9
PM10 reduction vs. scrapped [lbs]	0.1	0.1	0.1	0.1	0.1	0.1	0.1	0.1	0.1	0.1	0.1	0.1	1.0
GHG reduction vs scrapped [short tons]	4.1	4.7	4.1	4.9	4.0	2.5	4.5	2.5	3.4	2.4	4.8	3.4	45.3
NOx reduction vs new diesel [lbs]	5.9	6.7	5.9	7.0	5.7	4.2	7.5	4.5	6.1	4.3	7.2	5.3	70.3
PM2.5 reduction vs. new diesel [lbs]	0.0	0.0	0.0	0.0	0.0	0.0	0.0	0.0	0.0	0.0	0.0	0.0	0.0
PM10 reduction vs. new diesel [lbs]	0.0	0.0	0.0	0.0	0.0	0.0	0.0	0.0	0.0	0.0	0.0	0.0	0.0
GHG reduction vs new diesel [short tons]	4.1	4.7	4.1	4.9	4.0	2.5	4.5	2.5	3.4	2.4	4.8	3.4	45.3

Appendix B: Loadshapes, Phantom Loading, and the Value of Sub-metering

As bus fleets convert more of their vehicles to electric drivetrains, the timing and degree of power draw on the grid will become increasingly important to consider. This is because time-of-use rates are often applied to large, commercial load centers by utilities with heavy draws during peak periods coming at a premium cost. If charging can be kept to a minimum during the peak usage times for one's utility, and the load can be shifted into the off-peak period, many thousands of dollars can be saved over the course of a year. Combined with the ability to detect unusual charging patterns or unexpected reduced loads indicating a hardware issue, it is thus prudent to carefully monitor power draws at the charging facility. The installation of utility-grade sub-meters will help bus fleets monitor power draws and will likely pay for themselves many times over across the decades of fleet operation.

One area where independent power logging has proven its value is in the detection of 'phantom loading', or low-level, unexpected power draws outside of normal operation. It was noted in the main body of the report that phantom loading was seen on all the Lion buses at CVSD and BUUSD/STA. It was uncovered that this draw was being used to allow the buses to reconnect to the chargers more easily for the purposes of thermal management. Many of FWSU's Blue Bird bus issues were also tied to thermal management and the buses' ability to pull power from the grid to serve thermal management needs. In the Blue Bird buses' case, the buses stop charging once the batteries are at maximum charge and then digitally 'disconnect' from the EVSE. Thermal management then pulls energy from the batteries. Although it saves energy and likely presents few issues in warmer climates, it may be one of the reasons as to why this pilot saw appreciable range reduction on the Blue Bird buses as temperatures dropped.

Lion appears to have taken the opposite approach to solve the same problem. Lion reports that their buses are designed to continue drawing power even after the batteries are charged, so that thermal management energy can be pulled from the grid when needed and the bus can start its next run with the maximum range available. The financial impact of this extra usage is estimated to be between \$1,000 to \$2,500 annually per bus, with costs varying by the length of time buses are plugged-in but not charging.

A further contributor to this phantom load effect is related to the type of charger being used. CVSD experienced phantom loading on its ABB chargers, but did not on the initial, temporary Clipper Creek chargers. BUUSD/STA had phantom loads on both their temporary Delta chargers and their permanent ABB chargers. For Blue Bird, while the Level 2 Nuuve chargers are shutting down once batteries are full, the bus vendor speculated that if higher power 'DC fast charge' chargers were installed that this issue might resolve itself, though how that would change things was not made clear.

The issue seems like a solvable one, and both bus manufacturers are actively pursuing software fixes which would allow a bus to 'reconnect' to grid power when needed for thermal management but stop drawing power when it is not needed.

The issue has ramifications for the pilot project. If a solution is brought to bear that eliminates the excess usage then the Lion bus energy savings would significantly improve various performance metrics, particularly for fuel savings and vehicle efficiency.

The following chart, Figure 1-B, combining power usage from both of BUUSD’s chargers over a three-month span in 2022, shows 3 modes: charging times; a near-zero load for July-August; and low-loading at all other times, particularly at the trailing end of June. The spike at the beginning of June is simply the overlap between both charges being used at the same time.

Figure 1-B: Screen capture of BUUSD/STA’s sub-meter dashboard, showing the combined power draw of the two buses from May – August of 2022.

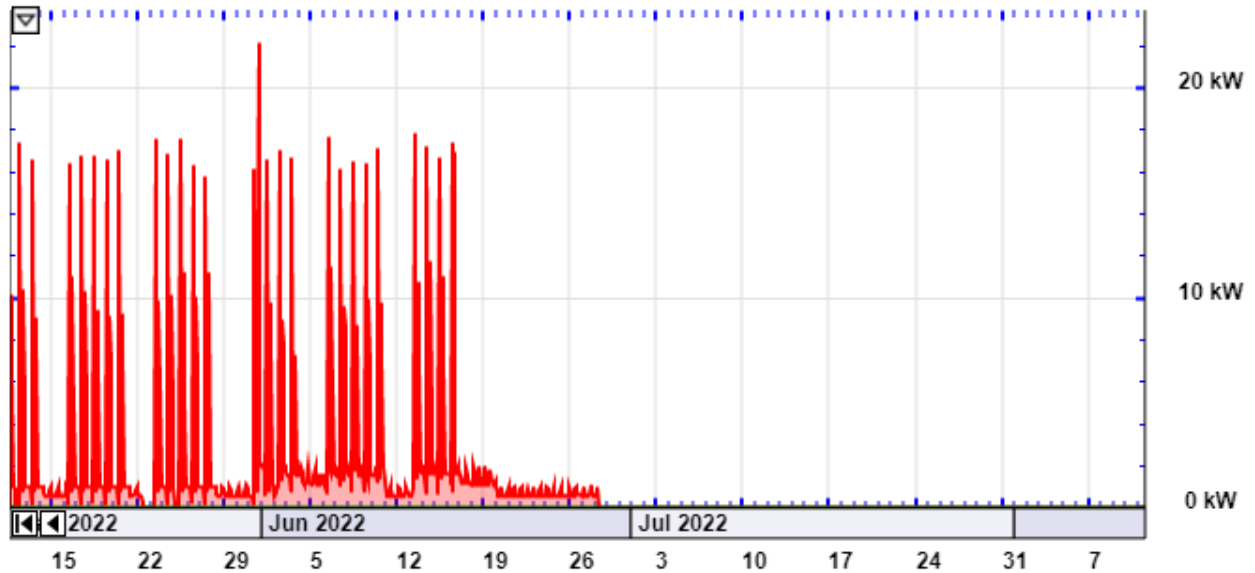

Other charging issues can also be detected when the charging trends are analyzed over time. As part of the evaluation of MVRTD’s Gillig buses, the team utilized Advanced Metering Infrastructure (AMI) data from Green Mountain Power. The trend seen in Figure 2-B, where the two identical chargers appear to have quite different peak loads, was noticed when comparing the east-lot charger data versus the west-lot charger data.

Figure 2-B: Power draws for MVRTD's Gillig buses in January of 2023.

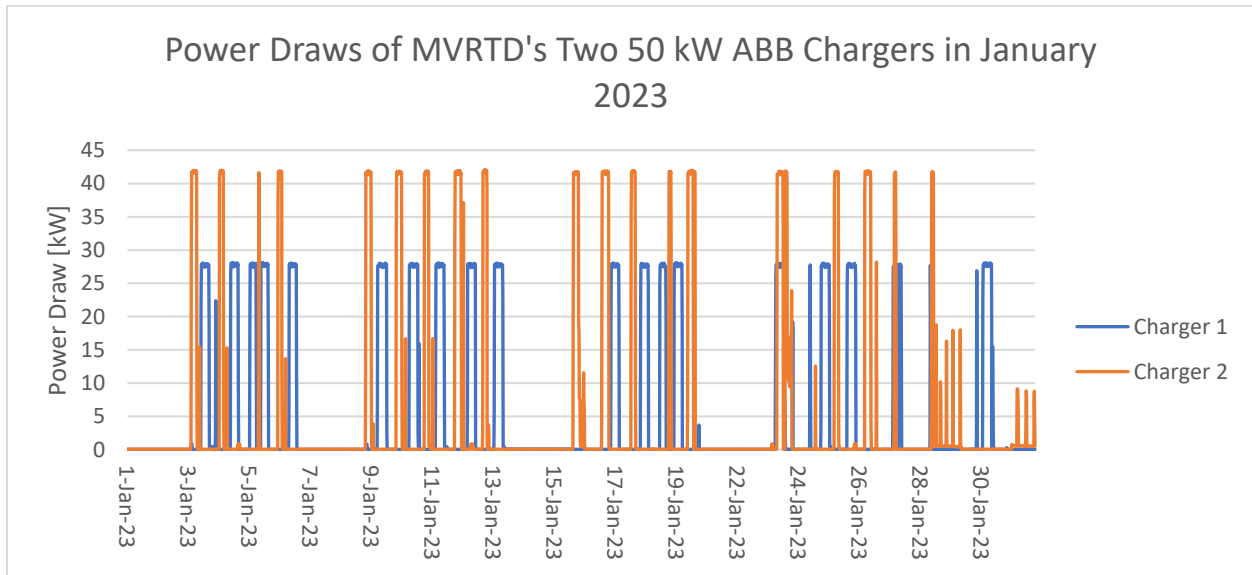

When overlapped in this way, it is immediately obvious that the west-lot charger is pulling significantly less draw at maximum loading than the east-lot charger is. This is despite both chargers and buses being essentially identical. Also, both chargers are pulling draws well below the expected 50 kW these chargers should be able to provide. The cause(s) was still under investigation at the time of this report's publication. Fortunately, the reduced charge level does not appear to have impacted operations.

A similar issue was noted at FWSU in October of 2021, as seen in Figure 3-B, soon after the buses first arrived. In that case, it was eventually determined that one of the three onboard inverter couplings was loose on one bus.

Figure 3-B: Power draws from FWSU's two chargers in October of 2021.

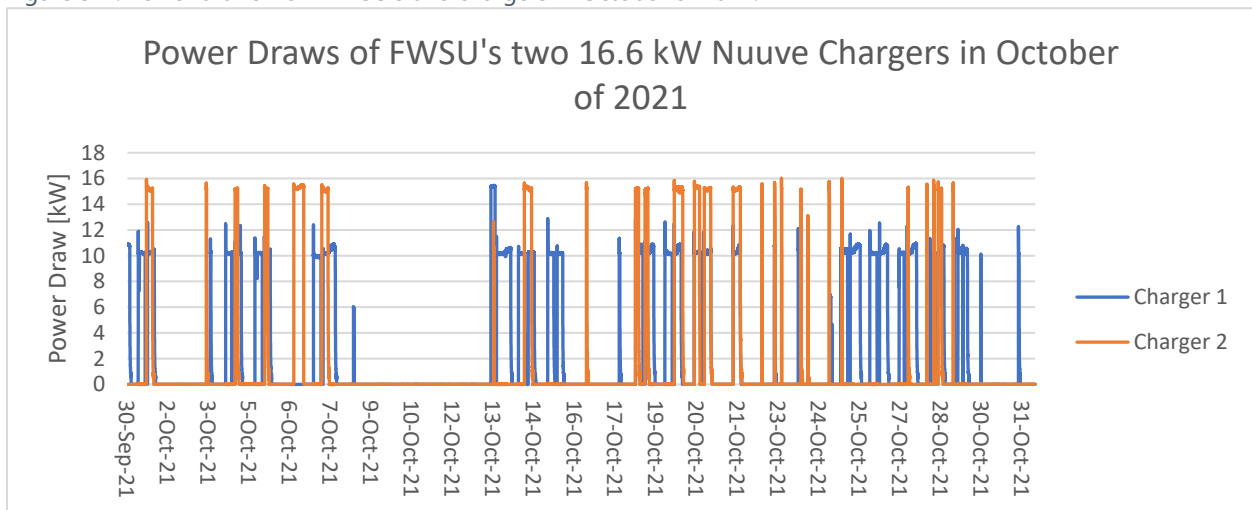

The above findings, along with the unlikelihood of these subtle issues being caught during regular maintenance checks, as well as our previous reporting about phantom loading, all support the view that access to energy sub-metering data is a valuable tool to aid in both operations and maintenance. AMI data can serve this need as well, where available, but only if the data can be broken out by charger per bus and has at least hourly granularity – preferably 15-minute or better.

Another use for load monitoring data is that it can be used to help maximize operational efficiency and minimize fuel costs for an electric vehicle fleet. VEIC developed a time-of-use modeling tool to aid MVRTD in its managed charging plans. While all the project partners are currently permitted to stay on Green Mountain Power's basic, flat-cost Rate 6 plan through July of 2023, at that point MVRTD is likely to shift to the utility's Rate 63/65 which will vary the cost of electricity based on when and at what level power is drawn. Power drawn during the peak period of 6 a.m. to 11 p.m. is more than four times as expensive as 'off-peak' draw.

Utilizing this tool, it was uncovered that it would be advantageous for the district to make some changes to operations. First, the utility service could be shifted over to Rate 63/65. Then, MVRTD can set its managed charging schedule to draw power during off-peak hours. Additionally, the managed charging software can throttle back the power level while expanding the duration of the charge. Combined, this would currently save MVRTD around \$400 per month per bus. Once the bus is on Rate 63/65, the difference between the worst- and best-case charge schedules equates to an annual fuel costs difference of over \$23,000 for the two buses combined.

Appendix C: Details on School Bus Maintenance Issues

Fleet	OEM	Date Reported	Project Phase	Days Downtime	last 4 VIN	Vehicle System Affected	Issue description
CVSD	Lion	8/24/2021	Initial inspection			EVSE	Temporary Clipper Creek charger would not draw power.
CVSD	Lion	8/26/2021	Initial inspection		8056	Body	12VDC compartment door improper weather sealing
CVSD	Lion	8/26/2021	Initial inspection		8020	Body	12VDC compartment door improper weather sealing
CVSD	Lion	8/26/2021	Initial inspection		8056	Body	Panel below dash computer not fitted properly leaving gap.
CVSD	Lion	8/31/2021	Initial inspection			EVSE	ABB chargers are not correct voltage for site.
CVSD	Lion	9/1/2021	Monitoring period		8056	Controls/software	Slow Speed Noise machine too loud
CVSD	Lion	9/9/2021	Monitoring period	1.5	8020	Brakes	Parking break stuck
CVSD	Lion	9/29/2021	Monitoring period		8056	EVSE	Charger triped breaker
CVSD	Lion	10/1/2021	Monitoring period		8056	Preventative	Doc holder install, radio install, preventative
CVSD	Lion	10/14/2021	Monitoring period		8020	Brakes	Breaks keep engaaging, break pads are needing to be replaced alr
CVSD	Lion	10/14/2021	Monitoring period		8056	EVSE	Charger keeps giving error
CVSD	Lion	11/1/2021	Monitoring period		8020	Body	Door is glitchy for opening
CVSD	Lion	1/1/2022	Monitoring period	5	8020	Controls/software	High-voltage Interlock sensor fault
CVSD	Lion	1/3/2022	Monitoring period		8020	Preventative	Grease and PM
CVSD	Lion	3/1/2022	Monitoring period		8020	Brakes	e-Brake assembly replaced by OEM
CVSD	Lion	4/1/2022	Monitoring period	5	8020	Thermal Management	Thermal Management fault
CVSD	Lion	7/31/2022	Monitoring period		8056	Preventative	Wiper replacement, grease and PM, Inspect
CVSD	Lion	7/31/2022	Monitoring period		8020	Preventative	Grease and PM
CVSD	Lion	9/1/2022	Monitoring period	6	8020	Drivetrain	Bus run in very hot weather till totally dead. Towed to EVSE, but would not take a charge.

Fleet	OEM	Date Reported	Project Phase	Days Downtime	last 4 VIN	Vehicle System Affected	Issue description
STA/BUUSD	Lion	4/1/2022	Monitoring period	26	8019	Drivetrain	Lithium Battery pack replacement
STA/BUUSD	Lion	5/1/2022	Monitoring period	15	8058	Body	Broken window
STA/BUUSD	Lion	8/1/2022	Monitoring period	1	8058	Brakes	E-brake assembly issue
STA/BUUSD	Lion	10/1/2022	Monitoring period	30	8019	Drivetrain	fuse shortages

Fleet	Date			Days		Vehicle System		
	OEM	Reported	Project Phase	Downtime	last 4 VIN	Affected	Issue description	
FWSU	Blue Bird	7/19/2021	Initial inspection			1981	Body	Bumpers not painted blue
FWSU	Blue Bird	7/19/2021	Initial inspection			1981	Body	Wheels not painted blue
FWSU	Blue Bird	7/19/2021	Initial inspection			1981	Body	Fuse compartment door slightly bent
FWSU	Blue Bird	7/19/2021	Initial inspection			1981	Suspension	Odd spacer between frame and spring on left side
FWSU	Blue Bird	7/19/2021	Initial inspection			1981	Thermal Management	No gauge or sight glass on diesel tank
FWSU	Blue Bird	7/19/2021	Initial inspection			1982	Body	Bumpers not painted blue
FWSU	Blue Bird	7/19/2021	Initial inspection			1982	Body	Wheels not painted blue
FWSU	Blue Bird	7/19/2021	Initial inspection			1982	Body	Fuse compartment door slightly bent
FWSU	Blue Bird	7/19/2021	Initial inspection			1982	Suspension	Odd spacer between frame and spring on left side
FWSU	Blue Bird	7/19/2021	Initial inspection			1982	Thermal Management	No gauge or sight glass on diesel tank
FWSU	Blue Bird	7/19/2021	Initial inspection			1982	Tags/certs	Wrong emmissions control sticker
FWSU	Blue Bird	7/19/2021	Initial inspection			1981	Drivetrain	Only charging at 11kW, rather than 16.6kW as expected
FWSU	Blue Bird	7/22/2021	Initial inspection			1981	Compressed Air	Leaky leveling valve quick connect fitting for air supply
FWSU	Blue Bird	7/22/2021	Initial inspection			1981	Chasis	No front dust shields
FWSU	Blue Bird	7/22/2021	Initial inspection			1981	Chasis	No Front tow hooks
FWSU	Blue Bird	7/22/2021	Initial inspection			1981	Chasis	No rear tow hooks
FWSU	Blue Bird	7/22/2021	Initial inspection			1981	Body	Bolts are not undercoated on drivers seat
FWSU	Blue Bird	7/22/2021	Initial inspection			1982	Compressed Air	Leaky trendle valve 5/8" green airline quick connect fitting
FWSU	Blue Bird	7/22/2021	Initial inspection			1982	Body	Chasis grill painted black, supposed to be yellow
FWSU	Blue Bird	7/22/2021	Initial inspection			1982	Thermal Management	No vent hose on coolant resevoir cap
FWSU	Blue Bird	9/1/2021	Monitoring period			1981	Body	Water penetration into electrical
FWSU	Blue Bird	9/1/2021	Monitoring period			1981	Brakes	E-Brake adjustment
FWSU	Blue Bird	10/1/2021	Monitoring period		3	1981	Body	Hood replacement
FWSU	Blue Bird	10/1/2021	Monitoring period		9	1982	Controls/software	Error code
FWSU	Blue Bird	11/1/2021	Monitoring period			1982	Thermal Management	Thermal Management not supplying heat
FWSU	Blue Bird	11/1/2021	Monitoring period			1981	Thermal Management	Thermal Management not supplying heat
FWSU	Blue Bird	12/1/2021	Monitoring period		14	1982	Drivetrain	Traction Inverter Replacement
FWSU	Blue Bird	12/1/2021	Monitoring period		18	1981	Thermal Management	Coolant Pump failure
FWSU	Blue Bird	1/1/2022	Monitoring period		17	1981	Drivetrain	Traction Inverter
FWSU	Blue Bird	1/1/2022	Monitoring period		20	1982	Mechanic Delays	Mechanic delays - bus sitting in lot
FWSU	Blue Bird	2/1/2022	Monitoring period		15	1981	Mechanic Delays	Mechanic delays - bus sitting in lot
FWSU	Blue Bird	3/1/2022	Monitoring period		14	1981	Thermal Management	Wiring harness replacement
FWSU	Blue Bird	3/1/2022	Monitoring period		5	1982	Thermal Management	Wiring harness replacement
FWSU	Blue Bird	3/1/2022	Monitoring period		5	1982	Drivetrain	Traction Inverter programing issue
FWSU	Blue Bird	3/1/2022	Monitoring period		5	1982	Drivetrain	Drive motor replacement
FWSU	Blue Bird	3/1/2022	Monitoring period			1981	Drivetrain	Loose inverter plug
FWSU	Blue Bird	3/1/2022	Monitoring period			1981	12V system	12VDC battery replace
FWSU	Blue Bird	4/1/2022	Monitoring period		45	1981	Compressed Air	Air Compressor Failure
FWSU	Blue Bird	4/1/2022	Monitoring period		11	1982	Thermal Management	Coolant Pump failure
FWSU	Blue Bird	5/1/2022	Monitoring period			1981	Wheels and Tires	cupping on tires
FWSU	Blue Bird	5/1/2022	Monitoring period			1981	Thermal Management	coolant system maintenance (loose caps and clamps)
FWSU	Blue Bird	5/1/2022	Monitoring period			1982	Wheels and Tires	cupping on tires
FWSU	Blue Bird	5/1/2022	Monitoring period		11	1982	Suspension	U-bolt failure on suspension
FWSU	Blue Bird	5/1/2022	Monitoring period			1982	Drivetrain	chaffing on primary power wires
FWSU	Blue Bird	6/1/2022	Monitoring period			1981	Child Check	Alarm not functioning properly
FWSU	Blue Bird	6/1/2022	Monitoring period			1981	Thermal Management	Coolant pump faults
FWSU	Blue Bird	7/1/2022	Monitoring period			1981	Body	Service door fault
FWSU	Blue Bird	7/1/2022	Monitoring period			1982	Thermal Management	Coolant pump faults
FWSU	Blue Bird	8/1/2022	Monitoring period		1	1981	Thermal Management	drawing down lithium batteries needlessly
FWSU	Blue Bird	9/1/2022	Monitoring period		17	1982	Thermal Management	Thermal management controller 'heat event'
FWSU	Blue Bird	9/1/2022	Monitoring period		17	1981	Thermal Management	Cooling system failure
FWSU	Blue Bird	9/1/2022	Monitoring period		35	1982	Mechanic Delays	Mechanic delays - bus sitting in lot
FWSU	Blue Bird	10/1/2022	Monitoring period		17	1981	Thermal Management	Cooling system leak
FWSU	Blue Bird	11/1/2022	Monitoring period		15	1981	Thermal Management	Thermal Management improperly wired
FWSU	Blue Bird	11/1/2022	Monitoring period		18	1982	Thermal Management	Thermal Management controls issue
FWSU	Blue Bird	12/1/2022	Monitoring period		36	1981	EVSE	Charger faults
FWSU	Blue Bird	12/1/2022	Monitoring period		36	1982	EVSE	charger faults
FWSU	Blue Bird	1/1/2023	Monitoring period		5	1982	Thermal Management	wiring issue
FWSU	Blue Bird	2/1/2023	Monitoring period		15	1982	Mechanic Delays	botched parts installation, wrong part both ordered and installed
FWSU	Blue Bird	3/1/2023	Monitoring period		18	1981	Thermal Management	Wiring harness replacement
FWSU	Blue Bird	3/1/2023	Monitoring period		17	1982	Thermal Management	Wiring harness replacement

Appendix D: Project Partner Selection RFQ and RFP

Electric School and Transit Bus Pilot Program

School Transportation Providers, Request for Qualifications

Project Overview

The Vermont Department of Environmental Conservation (DEC) is launching an electric school and transit bus pilot program for the State of Vermont, funded by the Volkswagen Environmental Mitigation Trust (EMT). The pilot, administered by VEIC with support from the Vermont Energy Education Program (VEEP), will evaluate the feasibility and cost-effectiveness of electric school and transit bus operation in the state over a two-year period.

As described in its [Beneficiary Mitigation Plan](#), Vermont is prioritizing the expenditure of its EMT funds to advance electric vehicle use. The pilot aims to engage partners across the state and maximize the use of available EMT funds in an effective way, while also meeting specific criteria and priorities. These include:

- Testing and evaluating the viability of electric buses in Vermont as replacements for diesel-powered buses, across a range of route conditions, geographical areas, and types of weather.
- Maximizing air quality benefits by considering the engine model year and remaining vehicle life for the buses that are replaced, as well as by prioritizing areas that are disproportionately impacted by air contaminants in the state.
- Exposing Vermonters from different communities, demographic profiles, and geographic regions to electric bus technologies.

School Participation

In this pilot program, the EMT funds will be used to pay for the incremental cost of electric buses, (i.e. the costs above the price of a new comparable conventional bus); the expected trade-in value for the buses being replaced; and the required charging equipment and installation costs. Project Partners will deploy the electric buses in their regular transportation service, with a goal of maximizing eVMT (miles

driven powered by electricity) and commit to fully scrapping each diesel-powered bus replaced. Project Partners may include supervisory unions, school districts, or schools. For school entities utilizing transportation contractors, the school entity may apply on behalf of the school bus contractor(s). VEIC is interested in working with at least two school entities (or school bus service contractors) that will each replace no fewer than two diesel-powered buses with electric buses.

Request for Qualifications

VEIC, under contract with the DEC, is seeking qualifications from prospective Project Partners that will be selected through a competitive two-step application process. This Request for Qualifications (RFQ) is intended to determine basic eligibility and level of commitment. Recognizing that this technology will be new to many potential applicants, VEIC and VEEP are available to support you through this process. If you are interested but unsure of your eligibility, please reach out and we will be happy to help. Successful applicants will be invited to respond to a subsequent Request for Proposals (RFP).

Submission Details

Interested candidates should respond to the following questions under the Request for Qualifications heading below. Please be sure to review all Disclosures at the end of this document.

All responses must be submitted electronically to Kate Cahalane at kcahalane@veic.org by **August 16, 2019 at 5pm**.

Email subject line should read: Electric Bus Pilot_RFQ_School (or Contractor) Name

In you need assistance or have any questions, please contact Kate Cahalane at kcahalane@veig.org or 802-540-7814 or Cara Robeck at cara.robekchek@veep.or or 802-552-8674.



Request for Qualifications

1. School District / Supervisory Union / School

School District / Supervisory Union / School:	
School Bus Contractor name (if applicable):	
Contact person, position, contact information:	
Street address:	
City / Town:	
Number of students enrolled as of June 2019:	

2. Existing School Bus Service

What is the maximum number of buses in service each day?	
How many bus routes do you operate daily?	
What is the distance (miles) of your average route?	
What is the distance (miles) of the shortest daily bus route in your network?	
What is the distance (miles) of the longest daily bus route in your network?	
Are your buses used for any purpose other than student transportation to and from school? If yes, please describe.	
Who operates your buses?	
Who owns and maintains your buses?	

Where are buses typically parked overnight? Are they in a covered facility?	
Are buses stored close to electric power access?	

3. The EMT funds can only be used to replace diesel-powered, 2009 *engine* model year (EMY) or older Class 4-8 school buses that have been and continue to be registered, inspected and in regular use in Vermont over the last calendar year prior to responding to this RFQ. It will be required that the diesel-powered buses selected for replacement be scrapped (with scrappage certification submitted) within 90 days of receiving replacement bus.

Please detail the buses you intend to replace. We are happy to help if you have any questions about how to determine engine model year (rather than vehicle model year) or any other fields here.

	Bus 1	Bus 2	Bus 3 (if applicable)
Bus Make, Model, and Age			
Bus Type / Class			
Engine Model Year			
Annual Miles Driven			
Originally Planned Replacement Date (if not for this pilot)			

Commitment to Scrap? (Yes / No)			
------------------------------------	--	--	--

4. To ensure electric buses are deployed within the timeframe of the pilot program, Project Partners will be required to purchase the new buses within twelve months of being selected.

Please indicate if you will be able to meet this deadline.

5. For the electric bus pilot program to be successful, it will be critical that Project Partners have adequate fleet / transportation staff for bus operation and maintenance to support the deployment of a new technology, incorporate the necessary protocols, and support data collection through the pilot period. VEIC will be supporting Project Partners through this transition, helping to facilitate the process and providing technical assistance.

Please describe your readiness to work with VEIC to manage a transition to electric buses in terms of availability and interest among staff.

6. Deploying electric school buses will require support and buy-in from Project Partner personnel, including management.

Please describe the extent to which various stakeholders have been engaged to date and their level of support. Stakeholders can include bus drivers, maintenance staff, transportation coordinating staff, parents, teachers, school board, etc. If you haven't begun this process yet, please describe your plan for communication and coordination to secure the support needed for this project.



7. In addition to the importance of having support within the school community, a transition to electric buses will also require coordination with the local electric utility to determine feasibility from an electric infrastructure, supply, and cost perspective and to understand the implications of managed (or unmanaged) charging.

Please describe the extent to which you have engaged with your utility. If you haven't begun this process yet, please describe your plan for communication and coordination or indicate if you will need assistance to engage your utility.

8. To ensure the EMT funds are used efficiently and have the biggest impact possible, Project Partners will be expected to contribute matching funds equal to the cost of a new conventional bus (less the expected trade-in value for the buses being replaced).

Please describe the level of matching funds you will be able to contribute and indicate the sources of these funds. If you are currently unsure if you will be able to contribute the full cost of a new conventional bus, please describe the efforts you will take in attempts to secure this funding.

9. Please share any other information that you would like us to consider as we evaluate your eligibility for and level of commitment to the electric bus pilot program.

Disclosures

1. The State will make no attempt to contact interested parties with updated information. It is the responsibility of each interested party to periodically check <http://www.vermontbidsystem.com> for any and all notifications, releases and amendments associated with the RFQ.
2. This RFQ does not constitute a Request for Proposal (RFP) or a promise to issue an RFP in the future. This RFQ does not commit the State to contract for any materials or service whatsoever. Further, the State is not at this time seeking proposals and will not accept unsolicited proposals.
3. Responders are advised that the State will not pay for any information or administrative costs incurred in response to this RFQ; all costs associated with responding to this RFQ will be solely at the interested party's expense.
4. After conclusion of the contracting/granting process, Proposals are a matter of public record. If an application includes material considered by the applicant to be proprietary and confidential under 1 V.S.A., Chapter 5, the application shall clearly designate the material as such and explain why such material should be considered confidential. The Vendor must identify each page or section of the Proposal that it believes is proprietary and confidential with sufficient grounds to justify each exemption from release, including the prospective harm to the competitive position of the applicant if the identified material were to be released.
5. Under no circumstances shall the entire Proposal be designated as proprietary or confidential. If the Vendor marks portions of the Proposal confidential, the Vendor shall provide a redacted version of the Proposal for release to the public. Notwithstanding the above, the Secretary has an independent obligation under Vermont law to determine whether any proposal material is subject to public inspection and copying upon request, which may include material that has otherwise been designated as proprietary and confidential by the Vendor. The Vendor's designation of material as proprietary and confidential, and submission of a redacted Proposal, are provided to the Secretary for informational purposes in the event the Agency receives a public records request and will not result in withholding of materials by the Secretary unless expressly supported by Vermont law.

Electric School and Transit Bus Pilot Program

Transit Providers, Request for Qualifications

Project Overview

The Vermont Department of Environmental Conservation (DEC) is launching an electric school and transit bus pilot program for the State of Vermont, funded by the Volkswagen Environmental Mitigation Trust (EMT). The pilot, administered by VEIC with support from the Vermont Energy Education Program (VEEP), will evaluate the feasibility and cost-effectiveness of electric school and transit bus operation in the state over a two-year period.

As described in its [Beneficiary Mitigation Plan](#), Vermont is prioritizing the expenditure of its EMT funds to advance electric vehicle use. The pilot aims to engage partners across the state and maximize the use of available EMT funds in an effective way, while also meeting specific criteria and priorities. These include:

- Testing and evaluating the viability of electric buses in Vermont as replacements for diesel-powered buses, across a range of route conditions, geographical areas, and types of weather.
- Maximizing air quality benefits by considering the engine model year and remaining vehicle life for the buses that are replaced, as well as by prioritizing areas that are disproportionately impacted by air contaminants in the state.
- Exposing Vermonters from different communities, demographic profiles, and geographic regions to electric bus technologies.

Transit Provider Participation

In this pilot program, the EMT funds will be used to pay for the incremental cost of electric buses, (i.e. the costs above the price of a new comparable conventional bus), as well as the required charging equipment and installation costs. Project Partners will deploy the electric buses in their regular transportation service, with a goal of maximizing eVMT (miles driven powered by electricity) and commit to fully

scrapping each diesel-powered bus replaced. Project Partners may include any transit providers. VEIC is interested in working with at least one transit provider that will replace no fewer than two diesel-powered buses with electric buses.

Request for Qualifications

VEIC, under contract with the DEC, is seeking qualifications from prospective Project Partners that will be selected through a competitive two-step application process. This Request for Qualifications (RFQ) is intended to determine basic eligibility and level of commitment. Recognizing that this technology will be new to many potential applicants, VEIC is available to support you through this process. If you are interested but unsure of your eligibility, please reach out and we will be happy to help. Successful applicants will be invited to respond to a subsequent Request for Proposals (RFP).

Submission Details

Interested candidates should respond to the following questions under the Request for Qualifications heading below. Please be sure to review all Disclosures at the end of this document.

All responses must be submitted electronically to Kate Cahalane at kcahalane@veic.org by **August 16, 2019 at 5pm**.

Email subject line should read: Electric Bus Pilot_RFQ_Transit Provider Name

In you need assistance or have any questions, please contact Kate Cahalane at kcahalane@veig.org or 802-540-7814.



Request for Qualifications

1. Transit Provider

Transit Provider name:	
Contact person, position, contact information:	
Street address:	
City / Town:	
Service Territory:	

2. Existing Transit Bus Service

What is the maximum number of buses in service each day?	
How many bus routes do you operate daily?	
What is the distance (miles) of your average route?	
What is the distance (miles) of the shortest daily bus route in your service territory?	
What is the distance (miles) of the longest daily bus route in your service territory?	
Where are buses parked overnight? Are they in a covered facility?	
Are buses stored in a location with access to 3-phase electric power?	

3. The EMT funds can only be used to replace diesel-powered, 2009 *engine* model year (EMY) or older Class 4-8 shuttle buses or transit buses that have been and continue to be registered, inspected and in regular use in Vermont over the last calendar year prior to responding to this RFQ. It will be required that the diesel-powered buses selected for replacement be scrapped (with scrappage certification submitted) within 90 days of receiving replacement bus.

Please detail the buses you intend to replace. We are happy to help if you have any questions about how to determine engine model year (rather than vehicle model year) or any other fields here.

	Bus 1	Bus 2	Bus 3 (if applicable)
Bus Make, Model, and Age			
Bus Type / Class			
Engine Model Year			
Annual Miles Driven			
Originally Planned Replacement Date (if not for this pilot)			
Commitment to Scrap? (Yes / No)			

4. To ensure electric buses are deployed within the timeframe of the pilot program, Project Partners will be required to purchase the new buses within twelve months of being selected.

Please indicate if you will be able to meet this deadline.

5. For the electric bus pilot program to be successful, it will be critical that Project Partners have adequate fleet / transportation staff for bus operation and maintenance to support the deployment of a new technology, incorporate the necessary protocols, and support data collection through the pilot period. VEIC will be supporting Project Partners through this transition, helping to facilitate the process and providing technical assistance.

Please describe your readiness to work with VEIC to manage a transition to electric buses in terms of availability and interest among staff.

6. Deploying electric buses will require support and buy-in from Project Partner personnel, including management.

Please describe the extent to which various stakeholders have been engaged to date and their level of support. Stakeholders can include bus drivers, maintenance staff, transportation coordinating staff, agency leadership, boards, etc. If you haven't begun this process yet, please describe your plan for communication and coordination to secure the support needed for this project.

7. In addition to the importance of having support internally, a transition to electric buses will also require coordination with the local electric utility to determine feasibility from an electric infrastructure, supply, and cost perspective and to understand the implications of managed (or unmanaged) charging.

Please describe the extent to which you have engaged with your utility. If you haven't begun this process yet, please describe your plan for communication and coordination or indicate if you will need assistance to engage your utility.

8. To ensure the EMT funds are used efficiently and have the biggest impact possible, Project Partners will be expected to contribute matching funds equal to the cost of a new conventional bus.

Please describe the level of matching funds you will be able to contribute and indicate the sources of these funds. If you are currently unsure if you will be able to contribute the full cost of a new conventional bus, please describe the efforts you will take in attempts to secure this funding.

9. Please share any other information that you would like us to consider as we evaluate your eligibility for and level of commitment to the electric bus pilot program.

Disclosures

1. The State will make no attempt to contact interested parties with updated information. It is the responsibility of each interested party to periodically check <http://www.vermontbidsystem.com> for any and all notifications, releases and amendments associated with the RFQ.
2. This RFQ does not constitute a Request for Proposal (RFP) or a promise to issue an RFP in the future. This RFQ does not commit the State to contract for any materials or service whatsoever. Further, the State is not at this time seeking proposals and will not accept unsolicited proposals.
3. Responders are advised that the State will not pay for any information or administrative costs incurred in response to this RFQ; all costs associated with responding to this RFQ will be solely at the interested party's expense.
4. After conclusion of the contracting/granting process, Proposals are a matter of public record. If an application includes material considered by the applicant to be proprietary and confidential under 1 V.S.A., Chapter 5, the application shall clearly designate the material as such and explain why such material should be considered confidential. The Vendor must identify each page or section of the Proposal that it believes is proprietary and confidential with sufficient grounds to justify each exemption from release, including the prospective harm to the competitive position of the applicant if the identified material were to be released.
5. Under no circumstances shall the entire Proposal be designated as proprietary or confidential. If the Vendor marks portions of the Proposal confidential, the Vendor shall provide a redacted version of the Proposal for release to the public. Notwithstanding the above, the Secretary has an independent obligation under Vermont law to determine whether any proposal material is subject to public inspection and copying upon request, which may include material that has otherwise been designated as proprietary and confidential by the Vendor. The Vendor's designation of material as proprietary and confidential, and submission of a redacted Proposal, are provided to the Secretary for informational purposes in the event the Agency receives a public records request and will not result in withholding of materials by the Secretary unless expressly supported by Vermont law.



128 Lakeside Avenue, Suite 401
Burlington, VT 05401
Toll-free: (800) 639-6069
veic.org

Electric School and Transit Bus Pilot Program

School Transportation Providers, Request for Proposals

Project Overview

The Vermont Department of Environmental Conservation (DEC) is launching an electric school and transit bus pilot program for the State of Vermont, funded by the Volkswagen Environmental Mitigation Trust (EMT). The pilot, administered by VEIC with support from the Vermont Energy Education Program (VEEP), will evaluate the feasibility and cost-effectiveness of electric school and transit bus operation in the state over a two-year period.

As described in its [Beneficiary Mitigation Plan](#), Vermont is prioritizing the expenditure of its EMT funds to advance electric vehicle use. The pilot aims to engage partners across the state and maximize the use of available EMT funds in an effective way, while also meeting specific criteria and priorities. These include:

- Testing and evaluating the viability of electric buses in Vermont as replacements for diesel-powered buses, across a range of route conditions, geographical areas, and types of weather.
- Maximizing air quality benefits by considering the engine model year and remaining vehicle life for the buses that are replaced, as well as by prioritizing areas that are disproportionately impacted by air contaminants in the state.
- Exposing Vermonters from different communities, demographic profiles, and geographic regions to electric bus technologies.

School Participation

In this pilot program, the EMT funds will be used to pay for the incremental cost of electric buses (i.e. the costs above the price of a new comparable conventional bus); the expected trade-in value for the buses being replaced; and the required

charging equipment and installation costs. Project Partners will deploy the electric buses in their regular transportation service, with a goal of maximizing eVMT (miles driven powered by electricity) and commit to fully scrapping each diesel-powered bus replaced. Project Partners may include supervisory unions or school districts. For school entities utilizing transportation contractors, the school entity may apply with the school bus contractor(s). VEIC is interested in working with at least two school entities (or school bus service contractors), and priority will be given to Project Partners who will replace no fewer than two diesel-powered buses with electric buses.

Request for Proposals

VEIC, under contract with the DEC, is seeking proposals from **invited** prospective Project Partners only, as established through a previous Request for Qualifications (RFQ) process. As with the RFQ, VEIC and VEEP are available to support you through this proposal process. Please reach out with any questions or to request support.

Submission Details

Applicants should compile a proposal document addressing the questions and including all information requested below. Proposals will be accepted as Word documents or PDF files.

Please be sure to review all Disclosures at the end of this document as well as the Standard State subcontract language to be included in any agreements resulting from this RFP.

All responses must be submitted electronically to Kate Cahalane at kcahalane@veic.org by **October 2, 2019 at 5 pm**.

Email subject line should read: Electric Bus Pilot_Proposal_School Name

In you need assistance or have any questions, please contact Kate Cahalane at kcahalane@veig.org or 802-540-7814 or Cara Robeck at cara.robekchek@veep.org or 802-552-8674.



Request for Proposals

Prospective Project Partners are invited to submit a proposal including the following information. Please be sure to address each section below in your proposal and label each section as labeled here. Hand written responses will not be accepted.

Background Information

Please include in your proposal background information on:

- School District / Supervisory Union name
- School Bus Contractor name (if applicable)
- Primary Point of Contact, position, and contact information
- Street Address
- Towns / region served
- Number of enrolled students

Buses to be Replaced

The EMT funds can only be used to replace diesel-powered, 2009 engine model year (EMY) or older Class 4-8 school buses that have been and continue to be registered, inspected and in regular use in Vermont for the 12 months prior to responding to this RFP. It will be required that the diesel-powered buses selected for replacement be scrapped (with scrappage certification submitted) within 90 days of receiving replacement bus, and **priority will be given to Project Partners who can replace and scrap at least two buses.**

For each bus planned for replacement, please document:

- Bus Make, Model, and Age
- Bus Type / Class
- Engine Model Year
- Annual Miles Driven
- Total Mileage
- Annual Fuel Use
- VIN

For each bus planned for replacement, we also ask that you include a description verifying that the bus is currently registered, inspected, and in regular use. Please describe your replacement plans for each bus, if not for this pilot. For example, is

the bus at the end of its useful life and in need of being replaced for the upcoming school year, or can you continue to use the bus and if so for how long.

Additionally, please indicate if any optional features (e.g. wheelchair lift, cameras) are included on the buses being replaced and / or if features will be required on the new electric buses.

Finally, you must certify that each bus planned for replacement has a 2009 engine model year (EMY) or older. Our preferred method of certification is to include a picture of the engine label. If this is not possible or if the label is missing, a signed letter indicating that the engine manufacturer has been contacted and the EMY verified will be required.

Existing Bus Service

One primary goal of the eBus Pilot is to test and evaluate the viability of electric buses across a range of route conditions and geographical areas. We are therefore, interested in carefully planning for a diversity of routes on which to test the buses. Please provide detailed information on as many daily routes as possible. At a minimum, please provide the following information for **at least three routes** that an electric school bus might serve. VEIC is available to assist you in identifying routes that may be appropriate for electric buses and can support you in compiling this information. **Contact Kate Cahalane at VEIC** to request assistance.

Please create a table in your proposal including the following information for **each** route.

	Route 1	Route 2	Route 3	Additional Routes
Total trips per day and approximate timing of trips (e.g. 1 morning and 1 afternoon, 2 morning and 2 afternoon, etc.)				
Miles per trip				
Trip duration				
Miles per day				



Bus type presently serving the route (A, C, D, or other)				
Route map included below (Y/N)				
Brief description of route, which includes information on whether there are paved or unpaved roads, maximum speed, hilly or flat terrain, and number of stops on the route. Feel free to provide additional relevant descriptions of the route.				
Maximum number of students served by the route				
Please indicate if there are any unique characteristics of this route that differentiate it from the overall population served				

Additionally, please provide information on other ways that the electric buses could be used to displace diesel bus use. Keep in mind that electric buses may have a range of only 60 miles on a single charge. For example:

- Are there summer school routes, or camp programs, or other summer transportation needs that could be served by the electric buses?
- Are there opportunities for the buses to be put into service on evenings, weekends, or for field trips mid-day?

Finally, please include the average price paid (\$/gallon) for diesel in the past year.

Infrastructure Planning

The cost of charging equipment necessary to fuel the electric buses and installation of that equipment will be covered by Volkswagen Settlement funds. Please describe your plans for school bus charging, including where buses are or will be parked and access to existing electrical infrastructure at that site (including specific distance to electric access), and the extent to which you have engaged with your utility to understand your electricity rates and how rate structures will impact the cost for fueling electric buses. VEIC will support all selected Project Partners in developing and implementing managed charging plans that minimize peak demand charges while accommodating operational needs. At this stage, we are primarily looking to understand site, location, and existing infrastructure considerations.

Please provide a map of the proposed electric school bus parking area showing proposed charger locations, bus parking locations, and location of electrical power sources. Consider and describe how you plan to accommodate the following:

- One charging station will be needed per bus
- Chargers are usually easiest to install nearer to existing electrical panels
- Buses will probably need to be parked and connected to the chargers overnight
- Minimizing infrastructure installation costs (e.g. designating spaces closest to the power access for the electric buses)
- Snow removal if buses are parked in an uncovered lot

Additionally, please describe any information obtained through conversations with your utility pertaining to necessary infrastructure upgrades and costs.

Purchases and Matching Funds

To ensure the EMT funds are used efficiently and have the biggest impact possible, Project Partners will be expected to contribute matching funds at least equal to the cost of a new conventional bus (less the expected trade-in value for the buses being replaced).

Please describe:

- The specific level of matching funds you will be able to contribute
- The specific sources of these matching funds, including documentation
- When these funds will be approved, when they will be available, and when funds must be expended

Additionally, to ensure electric buses are deployed within the timeframe of the pilot program, Project Partners will be required to order the new buses within 12 months of being selected, and it is our intention to order buses in March 2020. A deposit for the buses will be required at the time of purchase with the balance due upon delivery. Please describe how this timing aligns with the availability of your matching funds.

Deployment

For the electric bus pilot program to be successful, it will be critical that Project Partners have adequate fleet / transportation staff for bus operation and maintenance to support the deployment of a new technology, incorporate the necessary protocols, and support data collection through the pilot period.

Please describe the extent to which bus maintenance staff and drivers are engaged and supportive of the idea of electric buses. The questions below provide examples of the types of factors that maintenance staff and drivers should be considering:

- Spare parts and specialized tools – will anything new need to be kept in the shop? Will there be added costs? Does the workshop have a preferred bus manufacturer?
- Will staff be comfortable working on battery-electric vehicles after some basic training is provided by the manufacturer?
- If maintenance is provided by a third-party shop, are there any other considerations around parts availability or maintenance costs?
- Are drivers available to be trained on how to operate an electric bus?
- Are drivers able to and supportive of completing daily drivers' logs to capture mileage or other vehicle performance factors if data cannot be collected electronically?
- Costs for fueling electric buses will increase your electric bill and is unlikely to be itemized. Have you considered how this will impact budgeting and administration of fuel costs and your electric bill?

Additionally, please indicate who will be responsible for the following activities, percent of time they are available to support these activities, and what their role is within the school district:

- Participate in regular check-in calls with VEIC and other project partners
- Manage the installation of charging infrastructure
- Oversee development of bus specifications and participate in selection of vehicle manufacturer

- Support activities to accept vehicle delivery including inspection and registration
- Understand and implement the managed charging plan as developed with VEIC
- Report to VEIC within 24 hours if a bus is taken out of service for any reason
- Maintain records on all maintenance done on the buses
- Collect electric billing and usage information to monitor and manage energy costs
- Complete monthly reports (templates to be provided) to VEIC on all agreed upon data collection and ensure daily drivers' logs are maintained

Commitment and Support

A successful pilot project requires support from a variety of stakeholders, including parents, teachers, community leaders, and others. Letters of support are required from your local utility and school district leadership. **Other letters of support that demonstrate depth of community support are encouraged.**

Utility Letter of Support

A transition to electric buses will require coordination with the local electric utility to assist with site planning and installation of charging equipment, understand your cost of electricity and rate structure that could impact those costs, and to develop a plan to manage charging and therefore manage your fuel costs. It is also possible that your utility may be able to provide a cash incentive for the electric buses or charging equipment or provide discounted rates for electric service to charge the buses. It will also be critical to discuss with your utility whether upgrades to your site's electrical service will be necessary and what the costs of those upgrades will be.

To verify that you have engaged with your utility, please include a Letter of Support from your utility confirming their willingness to play an active role in this pilot and the type of support they will provide. VEIC can help support and facilitate these conversations with your utility if needed.

Leadership Letter of Commitment

Deploying electric buses will require support and buy-in from Project Partner personnel and stakeholder engagement with bus drivers, maintenance staff, transportation coordinating staff, parents, teachers, the school board, and more.

Please include a Letter of Commitment, signed by your Superintendent or the Chair of the School Board, confirming your commitment to:

- Engage staff;
- Scrap buses being replaced;
- Provide matching funds;
- Purchase electric buses within 12 months;
- Fulltime deployment of electric buses with the goal of maximizing eVMT;
- Report data to VEIC for the length of the pilot program and continue partial data reporting to the State for as long as the vehicle is in use; and
- Continue to use electric buses and equipment purchased after the term of the pilot program.

Additional Information

Please share any other information that you would like us to consider as we evaluate your proposal to the electric bus pilot program. As noted above, VEIC and VEEP are available to support you through this proposal process. Please reach out with any questions or to request support.

Disclosures

1. The State will make no attempt to contact interested parties with updated information. It is the responsibility of each interested party to periodically check <http://www.vermontbidsystem.com> for any and all notifications, releases and amendments associated with the RFP.
2. This RFP does not commit the State to contract for any materials or service whatsoever.
3. Responders are advised that the State will not pay for any information or administrative costs incurred in response to this RFP; all costs associated with responding to this RFP will be solely at the interested party's expense.
4. After conclusion of the contracting/granting process, Proposals are a matter of public record. If an application includes material considered by the applicant to be proprietary and confidential under 1 V.S.A., Chapter 5, the application shall clearly designate the material as such and explain why such material should be considered confidential. The applicant must identify each page or section of the Proposal that it believes is proprietary and confidential with sufficient grounds to justify each exemption from release, including the prospective harm to the competitive position of the applicant if the identified material were to be released.
5. Under no circumstances shall the entire Proposal be designated as proprietary or confidential. If the applicant marks portions of the Proposal confidential, the applicant shall provide a redacted version of the Proposal for release to the public. Notwithstanding the above, the Secretary has an independent obligation under Vermont law to determine whether any proposal material is subject to public inspection and copying upon request, which may include material that has otherwise been designated as proprietary and confidential by the applicant. The applicant's designation of material as proprietary and confidential, and submission of a redacted Proposal, are provided to the Secretary for informational purposes in the event the Agency receives a public records request and will not result in withholding of materials by the Secretary unless expressly supported by Vermont law.

Language to be included in all subcontracting agreements

1. Fair Employment Practices and Americans with Disabilities Act: Party agrees to comply with the requirement of 21 V.S.A. Chapter 5, Subchapter 6, relating to fair employment practices, to the full extent applicable. Party shall also ensure, to the full extent required by the Americans with Disabilities Act of 1990, as amended, that qualified individuals with disabilities receive equitable access to the services, programs, and activities provided by the Party under this Agreement.

2. False Claims Act: The Party acknowledges that it is subject to the Vermont False Claims Act as set forth in 32 V.S.A. § 630 *et seq.* If the Party violates the Vermont False Claims Act it shall be liable to the State for civil penalties, treble damages and the costs of the investigation and prosecution of such violation, including attorney's fees, except as the same may be reduced by a court of competent jurisdiction. The Party's liability to the State under the False Claims Act shall not be limited notwithstanding any agreement of the State to otherwise limit Party's liability.

3. Whistleblower Protections: The Party shall not discriminate or retaliate against one of its employees or agents for disclosing information concerning a violation of law, fraud, waste, abuse of authority or acts threatening health or safety, including but not limited to allegations concerning the False Claims Act. Further, the Party shall not require such employees or agents to forego monetary awards as a result of such disclosures, nor should they be required to report misconduct to the Party or its agents prior to reporting to any governmental entity and/or the public.

4. Taxes Due to the State:

- A. Party understands and acknowledges responsibility, if applicable, for compliance with State tax laws, including income tax withholding for employees performing services within the State, payment of use tax on property used within the State, corporate and/or personal income tax on income earned within the State.
- B. Party certifies under the pains and penalties of perjury that, as of the date the Agreement is signed, the Party is in good standing with respect to, or in full compliance with, a plan to pay any and all taxes due the State of Vermont.

C. Party understands that final payment under this Agreement may be withheld if the Commissioner of Taxes determines that the Party is not in good standing with respect to or in full compliance with a plan to pay any and all taxes due to the State of Vermont.

D. Party also understands the State may set off taxes (and related penalties, interest and fees) due to the State of Vermont, but only if the Party has failed to make an appeal within the time allowed by law, or an appeal has been taken and finally determined and the Party has no further legal recourse to contest the amounts due.

5. Child Support: (Only applicable if the Party is a natural person, not a corporation or partnership.) Party states that, as of the date this Agreement is signed, he/she:

A. is not under any obligation to pay child support; or

B. is under such an obligation and is in good standing with respect to that obligation; or

C. has agreed to a payment plan with the Vermont Office of Child Support Services and is in full compliance with that plan.

Party makes this statement with regard to support owed to any and all children residing in Vermont. In addition, if the Party is a resident of Vermont, Party makes this statement with regard to support owed to any and all children residing in any other state or territory of the United States.

6. No Gifts or Gratuities: Party shall not give title or possession of anything of substantial value (including property, currency, travel and/or education programs) to any officer or employee of the State during the term of this Agreement.

7. Certification Regarding Debarment: Party certifies under pains and penalties of perjury that, as of the date that this Agreement is signed, neither Party nor Party's principals (officers, directors, owners, or partners) are presently debarred, suspended, proposed for debarment, declared ineligible or excluded from participation in Federal programs, or programs supported in whole or in part by Federal funds. Party further certifies under pains and penalties of perjury that, as of the date that this Agreement is signed, Party is not presently debarred, suspended, nor named on the State's debarment list at:

<http://bgs.vermont.gov/purchasing/debarment>



8. Certification Regarding Use of State Funds: If Party is an employer and this Agreement is a State funded Grant in excess of \$1,001, Party certifies that none of these State funds will be used to interfere with or restrain the exercise of Party's employee's rights with respect to unionization.

9. State Facilities: If the State makes space available to the Party in any State facility during the term of this Agreement for purposes of the Party's performance under this Agreement, the Party shall only use the space in accordance with all policies and procedures governing access to and use of State facilities which shall be made available upon request. State facilities will be made available to Party on an "AS IS, WHERE IS" basis, with no warranties whatsoever.

10. Location of State Data: No State data received, obtained, or generated by the Party in connection with performance under this Agreement shall be processed, transmitted, stored, or transferred by any means outside continental United States, except with the express written permission of the State.

11. Subcontractors: Contractor shall not assign or subcontract the performance of this agreement or any portion thereof to any other contractor without the prior written approval of the State. Contractor also agrees to include in all subcontract agreements a tax certification in accordance with paragraph 11 above.



128 Lakeside Avenue, Suite 401
Burlington, VT 05401
Toll-free: (800) 639-6069
veic.org

Electric School and Transit Bus Pilot Program

Transit Providers, Request for Proposals

Project Overview

The Vermont Department of Environmental Conservation (DEC) is launching an electric school and transit bus pilot program for the State of Vermont, funded by the Volkswagen Environmental Mitigation Trust (EMT). The pilot, administered by VEIC with support from the Vermont Energy Education Program (VEEP), will evaluate the feasibility and cost-effectiveness of electric school and transit bus operation in the state over a two-year period.

As described in its [Beneficiary Mitigation Plan](#), Vermont is prioritizing the expenditure of its EMT funds to advance electric vehicle use. The pilot aims to engage partners across the state and maximize the use of available EMT funds in an effective way, while also meeting specific criteria and priorities. These include:

- Testing and evaluating the viability of electric buses in Vermont as replacements for diesel-powered buses, across a range of route conditions, geographical areas, and types of weather.
- Maximizing air quality benefits by considering the engine model year and remaining vehicle life for the buses that are replaced, as well as by prioritizing areas that are disproportionately impacted by air contaminants in the state.
- Exposing Vermonters from different communities, demographic profiles, and geographic regions to electric bus technologies.

Transit Agency Participation

In this pilot program, the EMT funds will be used to pay for up to 75% of the costs of the electric buses as well as up to 100% of the additional costs for necessary charging equipment and installation. Project Partners will deploy the electric buses

in their regular transportation service, with a goal of maximizing eVMT (miles driven powered by electricity) and commit to fully scrapping each diesel-powered bus replaced. Project Partners may include any transit providers. VEIC is interested in working with at least one transit provider, and priority will be given to Project Partners who will replace no fewer than two diesel-powered buses with electric buses.

Request for Proposals

VEIC, under contract with the DEC, is seeking proposals from **invited** prospective Project Partners only, as established through a previous Request for Qualifications (RFQ) process. As with the RFQ, VEIC is available to support you through this proposal process. Please reach out with any questions or to request support.

Submission Details

Applicants should compile a proposal document addressing the questions and including all information requested below. Proposals will be accepted as Word documents or PDF files.

Please be sure to review all Disclosures at the end of this document as well as the Standard State subcontract language to be included in any agreements resulting from this RFP.

All responses must be submitted electronically to Kate Cahalane at kcahalane@veic.org by **October 2, 2019 at 5 pm**.

Email subject line should read: Electric Bus Pilot_Proposal_Transit Provider Name

In you need assistance or have any questions, please contact Kate Cahalane at kcahalane@veig.org or 802-540-7814.



Request for Proposals

Prospective Project Partners are invited to submit a proposal including the following information. Please be sure to address each section below in your proposal and label each section as labeled here. Hand written responses will not be accepted.

Background Information

Please include in your proposal background information on:

- Transit agency name
- Primary Point of Contact, position, and contact information
- Street Address
- Service Territory – towns / region served
- Previous experience with electric buses

Buses to be Replaced

The EMT funds can only be used to replace diesel-powered, 2009 engine model year (EMY) or older Class 4-8¹ shuttle buses or transit buses that have been and continue to be registered, inspected and in regular use in Vermont for the 12 months prior to responding to this RFP. It will be required that the diesel-powered buses selected for replacement be scrapped (with scrappage certification submitted) within 90 days of receiving replacement bus, and **priority will be given to Project Partners who can replace and scrap at least two buses.**

For each bus planned for replacement, please document:

- Bus Make, Model, and Age
- Bus Type / Class
- Engine Model Year
- Annual Miles Driven
- Total Mileage
- Annual Fuel Use
- VIN

For each bus planned for replacement, we also ask that you include a description verifying that the bus is currently registered, inspected, and in regular use. Please

¹ Class 4-8 refer to vehicle classifications based on Gross Vehicle Weight Rating (<https://afdc.energy.gov/data/10380>)

describe your replacement plans for each bus, if not for this pilot. For example, is the bus at the end of its useful life and in need of being replaced immediately, or can you continue to use the bus and if so for how long.

Additionally, please indicate if any optional features (e.g. wheelchair lift, cameras) are included on the buses being replaced and / or if features will be required on the new electric buses.

Finally, you must certify that each bus planned for replacement has a 2009 engine model year (EMY) or older. Our preferred method of certification is to include a picture of the engine label. If this is not possible or if the label is missing, a signed letter indicating that the engine manufacturer has been contacted and the EMY verified will be required.

Existing Bus Service

One primary goal of the eBus Pilot is to test and evaluate the viability of electric buses across a range of route conditions and geographical areas. We are therefore, interested in carefully planning for a diversity of routes on which to test the buses. Please provide detailed information on as many daily routes as possible. At a minimum, please provide the following information for **at least three routes** that an electric bus might serve. VEIC is available to assist you in identifying routes that may be appropriate for electric buses and can support you in compiling this information. **Contact Kate Cahalane at VEIC** to request assistance.

Please create a table in your proposal including the following information for **each** route.

	Route 1	Route 2	Route 3	Additional Routes
Total trips per day				
Miles per trip				
Trip duration and approximate timing of trips				
Miles per day				
Bus type presently serving the route				



Route map included below (Y/N)				
Brief description of route, which includes information on whether there are paved or unpaved roads, maximum speed, hilly or flat terrain, and number of stops on the route. Feel free to provide additional relevant descriptions of the route.				
Number of riders served by the route				
Please indicate if there are any unique characteristics of this route that differentiate it from the overall population served				

Finally, please include the average price paid (\$/gallon) for diesel in the past year.

Infrastructure Planning

The cost of charging equipment necessary to fuel the electric buses and installation of that equipment will be covered by Volkswagen Settlement funds. Please describe your plans for electric bus charging, including where buses are or will be parked and access to existing electrical infrastructure at that site (including specific distance to electric access), and the extent to which you have engaged with your utility to understand your electricity rates and how rate structures will impact the cost for fueling electric buses. VEIC will support all selected Project Partners in developing and implementing managed charging plans that minimize peak demand charges while accommodating operational needs. At this stage, we are primarily looking to understand site, location, and existing infrastructure considerations.

Please provide a map of the proposed electric bus parking area showing proposed charger locations, bus parking locations, and location of electrical power sources. Consider and describe how you plan to accommodate the following:

- One charging station will be needed per bus (to ensure EMT funds are used efficiently, en route chargers will not be supported as part of this pilot program as they are cost prohibitive)
- Chargers are usually easiest to install nearer to existing electrical panels
- Buses will probably need to be parked and connected to the chargers overnight
- Minimizing infrastructure installation costs (e.g. designating spaces closest to the power access for the electric buses)
- Snow removal if buses are parked in an uncovered lot

Additionally, please describe any information obtained through conversations with your utility pertaining to necessary infrastructure upgrades and costs.

Purchases and Matching Funds

To ensure the EMT funds are used efficiently and have the biggest impact possible, Project Partners will be expected to contribute matching funds of at least 25% of the electric vehicle purchase costs.

Please describe:

- Total project cost estimates including electric vehicle purchases, charging infrastructure and installation
- The specific level of matching funds you will be able to contribute
- The specific sources of these matching funds, including documentation
- When these funds will be approved, when they will be available, and when funds must be expended

Additionally, to ensure electric buses are deployed within the timeframe of the pilot program, Project Partners will be required to order the new buses within 12 months of being selected.

Deployment

For the electric bus pilot program to be successful, it will be critical that Project Partners have adequate staff for bus operation and maintenance to support the deployment of a new technology, incorporate the necessary protocols, and support data collection through the pilot period.

Please describe the extent to which bus maintenance staff and drivers are engaged and supportive of the idea of electric buses. The questions below provide examples of the types of factors that maintenance staff and drivers should be considering:

- Spare parts and specialized tools – will anything new need to be kept in the shop? Will there be added costs? Does the workshop have a preferred bus manufacturer?
- Will staff be comfortable working on battery-electric vehicles after some basic training is provided by the manufacturer?
- If maintenance is provided by a third-party shop, are there any other considerations around parts availability or maintenance costs?
- Are drivers available to be trained on how to operate an electric bus?
- Are drivers able to and supportive of completing daily drivers' logs to capture mileage or other vehicle performance factors if data cannot be collected electronically?
- Costs for fueling electric buses will increase your electric bill and is unlikely to be itemized. Have you considered how this will impact budgeting and administration of fuel costs and your electric bill?

Additionally, please indicate who will be responsible for the following activities, percent of time they are available to support these activities, and what their role is within the transit agency:

- Participate in regular check-in calls with VEIC and other project partners
- Manage the installation of charging infrastructure
- Oversee development of bus specifications and participate in selection of vehicle manufacturer
- Support activities to accept delivery including inspection and registration
- Understand and implement the managed charging plan as developed with VEIC
- Report to VEIC within 24 hours if a bus is taken out of service for any reason
- Maintain records on all maintenance done on the buses
- Collect electric billing and usage information to monitor and manage energy costs
- Complete monthly reports (templates to be provided) to VEIC on all agreed upon data collection and ensure daily drivers' logs are maintained

Commitment and Support

A successful pilot project requires support from a variety of stakeholders, including bus drivers, maintenance staff, transportation coordinating staff, agency leadership, boards, and others. Letters of support are required from your local utility and agency leadership. **Other letters of support that demonstrate depth of community support are encouraged.**

Utility Letter of Support

A transition to electric buses will require coordination with the local electric utility to assist with site planning and installation of charging equipment, understand your cost of electricity and rate structure that could impact those costs, and to develop a plan to manage charging and therefore manage your fuel costs. It is also possible that your utility may be able to provide a cash incentive for the electric buses or charging equipment or provide discounted rates for electric service to charge the buses. It will also be critical to discuss with your utility whether upgrades to your site's electrical service will be necessary and what the costs of those upgrades will be.

To verify that you have engaged with your utility, please include a Letter of Support from your utility confirming their willingness to play an active role in this pilot and the type of support they will provide. VEIC can help support and facilitate these conversations with your utility if needed.

Leadership Letter of Commitment

Deploying electric buses will require support and buy-in from Project Partner personnel and stakeholder engagement with bus drivers, maintenance staff, transportation coordinating staff, agency leadership, boards, and more.

Please include a Letter of Commitment from your agency leadership confirming your commitment to:

- Engage staff;
- Scrap buses being replaced;
- Provide matching funds;
- Purchase electric buses within 12 months;
- Fulltime deployment of electric buses with the goal of maximizing eVMT;
- Report data to VEIC for the length of the pilot program and continue partial data reporting to the State for as long as the vehicle is in use; and
- Continue to use electric buses and equipment purchased after the term of the pilot program.

Additional Information

Please share any other information that you would like us to consider as we evaluate your proposal to the electric bus pilot program. As noted above, VEIC and VEEP are available to support you through this proposal process. Please reach out with any questions or to request support.

Disclosures

1. The State will make no attempt to contact interested parties with updated information. It is the responsibility of each interested party to periodically check <http://www.vermontbidsystem.com> for any and all notifications, releases and amendments associated with the RFP.
2. This RFP does not commit the State to contract for any materials or service whatsoever.
3. Responders are advised that the State will not pay for any information or administrative costs incurred in response to this RFP; all costs associated with responding to this RFP will be solely at the interested party's expense.
4. After conclusion of the contracting/granting process, Proposals are a matter of public record. If an application includes material considered by the applicant to be proprietary and confidential under 1 V.S.A., Chapter 5, the application shall clearly designate the material as such and explain why such material should be considered confidential. The applicant must identify each page or section of the Proposal that it believes is proprietary and confidential with sufficient grounds to justify each exemption from release, including the prospective harm to the competitive position of the applicant if the identified material were to be released.
5. Under no circumstances shall the entire Proposal be designated as proprietary or confidential. If the applicant marks portions of the Proposal confidential, the applicant shall provide a redacted version of the Proposal for release to the public. Notwithstanding the above, the Secretary has an independent obligation under Vermont law to determine whether any proposal material is subject to public inspection and copying upon request, which may include material that has otherwise been designated as proprietary and confidential by the applicant. The applicant's designation of material as proprietary and confidential, and submission of a redacted Proposal, are provided to the Secretary for informational purposes in the event the Agency receives a public records request and will not result in withholding of materials by the Secretary unless expressly supported by Vermont law.

Language to be included in all subcontracting agreements

1. Fair Employment Practices and Americans with Disabilities Act: Party agrees to comply with the requirement of 21 V.S.A. Chapter 5, Subchapter 6, relating to fair employment practices, to the full extent applicable. Party shall also ensure, to the full extent required by the Americans with Disabilities Act of 1990, as amended, that qualified individuals with disabilities receive equitable access to the services, programs, and activities provided by the Party under this Agreement.

2. False Claims Act: The Party acknowledges that it is subject to the Vermont False Claims Act as set forth in 32 V.S.A. § 630 *et seq.* If the Party violates the Vermont False Claims Act it shall be liable to the State for civil penalties, treble damages and the costs of the investigation and prosecution of such violation, including attorney's fees, except as the same may be reduced by a court of competent jurisdiction. The Party's liability to the State under the False Claims Act shall not be limited notwithstanding any agreement of the State to otherwise limit Party's liability.

3. Whistleblower Protections: The Party shall not discriminate or retaliate against one of its employees or agents for disclosing information concerning a violation of law, fraud, waste, abuse of authority or acts threatening health or safety, including but not limited to allegations concerning the False Claims Act. Further, the Party shall not require such employees or agents to forego monetary awards as a result of such disclosures, nor should they be required to report misconduct to the Party or its agents prior to reporting to any governmental entity and/or the public.

4. Taxes Due to the State:

- A. Party understands and acknowledges responsibility, if applicable, for compliance with State tax laws, including income tax withholding for employees performing services within the State, payment of use tax on property used within the State, corporate and/or personal income tax on income earned within the State.
- B. Party certifies under the pains and penalties of perjury that, as of the date the Agreement is signed, the Party is in good standing with respect to, or in full compliance with, a plan to pay any and all taxes due the State of Vermont.

- C. Party understands that final payment under this Agreement may be withheld if the Commissioner of Taxes determines that the Party is not in good standing with respect to or in full compliance with a plan to pay any and all taxes due to the State of Vermont.
- D. Party also understands the State may set off taxes (and related penalties, interest and fees) due to the State of Vermont, but only if the Party has failed to make an appeal within the time allowed by law, or an appeal has been taken and finally determined and the Party has no further legal recourse to contest the amounts due.

5. **Child Support:** (Only applicable if the Party is a natural person, not a corporation or partnership.) Party states that, as of the date this Agreement is signed, he/she:

- A. is not under any obligation to pay child support; or
- B. is under such an obligation and is in good standing with respect to that obligation; or
- C. has agreed to a payment plan with the Vermont Office of Child Support Services and is in full compliance with that plan.

Party makes this statement with regard to support owed to any and all children residing in Vermont. In addition, if the Party is a resident of Vermont, Party makes this statement with regard to support owed to any and all children residing in any other state or territory of the United States.

6. **No Gifts or Gratuities:** Party shall not give title or possession of anything of substantial value (including property, currency, travel and/or education programs) to any officer or employee of the State during the term of this Agreement.

7. **Certification Regarding Debarment:** Party certifies under pains and penalties of perjury that, as of the date that this Agreement is signed, neither Party nor Party's principals (officers, directors, owners, or partners) are presently debarred, suspended, proposed for debarment, declared ineligible or excluded from participation in Federal programs, or programs supported in whole or in part by Federal funds. Party further certifies under pains and penalties of perjury that, as of the date that this Agreement is signed, Party is not presently debarred, suspended, nor named on the State's debarment list at:

<http://bgs.vermont.gov/purchasing/debarment>

8. Certification Regarding Use of State Funds: If Party is an employer and this Agreement is a State funded Grant in excess of \$1,001, Party certifies that none of these State funds will be used to interfere with or restrain the exercise of Party's employee's rights with respect to unionization.

9. State Facilities: If the State makes space available to the Party in any State facility during the term of this Agreement for purposes of the Party's performance under this Agreement, the Party shall only use the space in accordance with all policies and procedures governing access to and use of State facilities which shall be made available upon request. State facilities will be made available to Party on an "AS IS, WHERE IS" basis, with no warranties whatsoever.

10. Location of State Data: No State data received, obtained, or generated by the Party in connection with performance under this Agreement shall be processed, transmitted, stored, or transferred by any means outside continental United States, except with the express written permission of the State.

11. Subcontractors: Contractor shall not assign or subcontract the performance of this agreement or any portion thereof to any other contractor without the prior written approval of the State. Contractor also agrees to include in all subcontract agreements a tax certification in accordance with paragraph 11 above.

Appendix E: Project Partner Agreement Template

Electric School and Transit Bus Pilot Program Participation Agreement

This Participation Agreement (the “Agreement”) is entered into between Vermont Energy Investment Corporation (“VEIC”) and [insert school or transit agency name] (“Project Partner”) and is effective as of the last date signed by both parties.

1. Introduction:

VEIC has been selected to administer an electric school and transit bus pilot program in Vermont (the “Program”) and the Project Partner below has been selected as a recipient of funding in order to participate in this Program. This Participation Agreement sets forth the rights and obligations of VEIC and Project Partner as part of Project Partner’s participation in, and VEIC’s assistance for, the Program.

2. Summary of the participation amounts and sources:

The below table summarizes the match commitments for participants, which participants are responsible for estimating based on the following criteria (and providing documentation upon request): For schools, the minimum match requirement is equivalent to the cost of a new conventional bus that is comparable to existing diesel buses in their fleet (less the expected trade in value for the buses to be replaced). For transit agencies, the match amount is equivalent to 25% of the cost of the electric buses. For transit agencies, the match requirement is subject to adjustment by mutual consent of both parties once final electric bus costs have been determined.

Matching Funds	Amount
School Contribution (only applicable to school Partners)	\$
Bus Contractor Contribution (if applicable to School Partners)	\$
Federal Transit Administration (only applicable to Transit Agency Partner)	\$
GMP Tier III Incentives	\$
Total Matching Funds:	\$

GMP Tier III Incentives listed above are an anticipated amount available from GMP, which will supplement the required match by Project Partner. In the event the GMP Tier III Incentives above are not available, Project Partner will not be expected to increase its match funding; rather, the funding will be available directly from the Volkswagen Environmental Mitigation Trust.

3. Maximum award amounts:

The maximum amount available for Project Partner is broken down into the following categories. The Total Estimated Project Costs below is subject to adjustment by mutual consent of both parties once final project costs have been determined.

Cost Component (Covered by EMT Funds)	Amount
Utility Infrastructure Upgrades	\$
Site Infrastructure Upgrades	\$
EVSE	\$
Data Capture and Monitoring Equipment	\$
Vehicle Purchase	\$
Total Estimated Project Costs:	

4. Milestone Timeline:

Project Partner and VEIC agree to the following Milestone Timeline for the duration of the Program:

Milestone	Timeframe
1. Vehicle and Equipment Selection and Purchase	<ul style="list-style-type: none"> • VEIC will submit RFPs for vehicles and EVSE to the State for approval one month after execution of this Project Partner Agreement; distribute RFPs to vehicle and EVSE vendors; and work with Project Partners to review responses and select vehicles for purchase; • VEIC will work with Project Partners and the State to purchase the selected buses and appropriate equipment. All buses and appropriate equipment must be ordered and purchased within twelve months of executing this Agreement.
2. Data Collection	<ul style="list-style-type: none"> • To begin upon bus deployment, for a minimum duration of 12 months; • VEIC will share a Data Collection plan with Project Partner staff prior to bus deployment.
3. Bus Scrappage	<ul style="list-style-type: none"> • Diesel buses being replaced must be scrapped within 90 days of receiving electric replacement bus; and • Scrappage certification form (to be provided by the State) and required photos in jpeg format within two weeks of scrappage.

5. Description of Participation; Roles and Responsibilities:

a. Vehicle and Equipment Selection:

- i. VEIC will work with Project Partners to determine technology specifications and write and distribute vehicle and electric vehicle supply equipment (EVSE) RFPs and determine criteria for evaluating responses. VEIC will also facilitate communications with bidders if needed and will provide support to Project Partners on negotiations with selected manufacturers. Contractor will ensure appropriate buses, and the EVSE necessary to charge the buses, are purchased by Project Partners.

- b. **Bus Deployment:** VEIC will be available to Project Partner fleet managers through the delivery and 12-month deployment of their buses to provide technical and logistical support, and ensure the buses meet all the specifications of the order. VEIC will be on hand when the vehicles undergo their safety inspection.

- c. **Training:** Project Partner's identified staff will participate in training coordinated by VEIC and vehicle vendors.

- d. **Communication:** Project Partners will participate in regular calls and check-ins organized by VEIC.

- i. **Weekly Calls.** Starting one month before vehicles are scheduled to arrive all staff who will interact and be affected by the buses will participate in weekly calls with all Project Partners lead by VEIC. Participants should include project leads, drivers, maintenance staff, schedulers, and may also include project champions (school board or transit board members, organizational leaders). The purpose of these calls is for Project Partners to share information with other Project Partners and VEIC on issues related to training, deployment, and data collection. Weekly calls will continue for at least one month into deployment and then shift to monthly calls.
- ii. **Weekly Check-ins.** Commencing upon execution of this Agreement, Project Partner team will participate in weekly check-ins with VEIC. After vehicles have been deployed for one month, the check-in frequency shall shift to bi-weekly for the duration of the project. The purpose of these check-ins will be to coordinate activities and roles to support project tasks, determine and monitor schedules, and vet challenges that arise throughout the term of this Agreement.

- e. **Proof of eligibility of existing buses:** Project Partner will provide proof of eligibility of the existing buses to be retired (Engine Model Year 2009 or older), upon VEIC's request, via email or as otherwise agreed to

between the parties. This proof will include, at a minimum, photo-documentation of VIN and engine labels, and copies of current registration and vehicle inspection report current as of October 2, 2019.

- f. Scrappage requirements and related documentation:** Project Partner must ensure that the retired buses are fully retired and scrapped, which includes the following requirements:
- i. Scrappage shall mean cutting a three-inch by three-inch hole in the engine block (the part of the engine containing the cylinders) and disabling the chassis by cutting through the frame/frame rails on each side at a point located between the front and rear axles.
 - ii. Photo documentation of vehicle scrappage must include the following photos as jpeg files – 1) side profile of bus, 2) VIN, 3) engine label showing Engine/Emissions Family, 4) chassis rails cut in half, 5) engine block, prior to hole, and 6) engine block, after hole.
 - iii. For each bus replaced under this Program, Project Partners shall be required to complete a scrappage certification form to be provided by the State. The scrappage certification form must be returned to VEIC fully completed.
- g. Disposition requirements:** Any equipment purchased by the Subrecipient under this Grant Agreement will remain the property of the Subrecipient and may not be transferred to another party without written permission from the State. Subrecipient agrees that at the end of the project period the Subrecipient will continue to use the equipment purchased under this assistance agreement in the project or program for which it was acquired as long as needed, whether or not the project or program continues to be supported by state funds.
- h. Data reporting requirements:** For a minimum deployment and data collection period of twelve (12) months, data shall be collected for each bus deployed. VEIC will identify Project Partner staff responsible for data collection as well as training and oversight needed to ensure protocols are being followed. VEIC will coordinate with Project Partners on data collection needs and the best, lowest-impact way to collect the data. At a minimum, daily route information and maintenance reports should be available with little or no impact on drivers. If mileage and energy data can be collected manually by drivers, this practice shall be encouraged to provide data redundancy. VEIC will interface with vehicle manufacturers to access data stored on the vehicles, if available. Key vehicle data shall include battery state of charge, hours of operation, and mileage. Charging station power data shall be transmitted wirelessly to VEIC directly or shall be downloaded by the Project Partner and emailed to VEIC monthly. Direct transmission of data will be dependent on site conditions and vehicle and EVSE specifications. Charging station power data will provide total power consumption, charge profile, actual charging schedules, and tracking of vampire loads.

6. Term and Termination:

This Agreement will take effect as of the last date signed below and, unless terminated earlier, will continue until both of the following occurred: (a) one (1) year after all of Project Partner's buses have been deployed and (b) VEIC has been able to collect 12 months of data for the Program. In the event of either party's material breach of this Agreement, the non-breaching party will have the option to terminate upon thirty (30) days' written notice, during which time the breaching party is afforded the opportunity, if possible, to cure the alleged breach.

7. Standard State subcontract language:

Project Partner understands and acknowledges that, to the extent applicable, it is bound by the Standard State Provisions for Contracts and Grants (Attachment C), attached hereto.

The parties have entered into this Agreement as of the last date signed below.

VEIC:

Project Partner:

By: _____

By: _____

Name: _____

Name: _____

Title: _____

Title: _____

Date: _____

Date: _____

**ATTACHMENT C: STANDARD STATE PROVISIONS
FOR CONTRACTS AND GRANTS
REVISED DECEMBER 15, 2017**

[We'll plan to attach this when we PDF]

**ATTACHMENT C: STANDARD STATE PROVISIONS
FOR CONTRACTS AND GRANTS
REVISED DECEMBER 15, 2017**

1. Definitions: For purposes of this Attachment, “Party” shall mean the Contractor, Grantee or Subrecipient, with whom the State of Vermont is executing this Agreement and consistent with the form of the Agreement. “Agreement” shall mean the specific contract or grant to which this form is attached.

2. Entire Agreement: This Agreement, whether in the form of a contract, State-funded grant, or Federally-funded grant, represents the entire agreement between the parties on the subject matter. All prior agreements, representations, statements, negotiations, and understandings shall have no effect.

3. Governing Law, Jurisdiction and Venue; No Waiver of Jury Trial: This Agreement will be governed by the laws of the State of Vermont. Any action or proceeding brought by either the State or the Party in connection with this Agreement shall be brought and enforced in the Superior Court of the State of Vermont, Civil Division, Washington Unit. The Party irrevocably submits to the jurisdiction of this court for any action or proceeding regarding this Agreement. The Party agrees that it must first exhaust any applicable administrative remedies with respect to any cause of action that it may have against the State with regard to its performance under this Agreement. Party agrees that the State shall not be required to submit to binding arbitration or waive its right to a jury trial.

4. Sovereign Immunity: The State reserves all immunities, defenses, rights or actions arising out of the State’s sovereign status or under the Eleventh Amendment to the United States Constitution. No waiver of the State’s immunities, defenses, rights or actions shall be implied or otherwise deemed to exist by reason of the State’s entry into this Agreement.

5. No Employee Benefits For Party: The Party understands that the State will not provide any individual retirement benefits, group life insurance, group health and dental insurance, vacation or sick leave, workers compensation or other benefits or services available to State employees, nor will the State withhold any state or Federal taxes except as required under applicable tax laws, which shall be determined in advance of execution of the Agreement. The Party understands that all tax returns required by the Internal Revenue Code and the State of Vermont, including but not limited to income, withholding, sales and use, and rooms and meals, must be filed by the Party, and information as to Agreement income will be provided by the State of Vermont to the Internal Revenue Service and the Vermont Department of Taxes.

6. Independence: The Party will act in an independent capacity and not as officers or employees of the State.

7. Defense and Indemnity: The Party shall defend the State and its officers and employees against all third party claims or suits arising in whole or in part from any act or omission of the Party or of any agent of the Party in connection with the performance of this Agreement. The State shall notify the Party in the event of any such claim or suit, and the Party shall immediately retain counsel and otherwise provide a complete defense against the entire claim or suit. The State retains the right to participate at its own expense in the defense of any claim. The State shall have the right to approve all proposed settlements of such claims or suits.

After a final judgment or settlement, the Party may request recoupment of specific defense costs and may file suit in Washington Superior Court requesting recoupment. The Party shall be entitled to recoup costs only upon a showing that such costs were entirely unrelated to the defense of any claim arising from an act or omission of the Party in connection with the performance of this Agreement.

The Party shall indemnify the State and its officers and employees if the State, its officers or employees become legally obligated to pay any damages or losses arising from any act or omission of the Party or an agent of the Party in connection with the performance of this Agreement.

Notwithstanding any contrary language anywhere, in no event shall the terms of this Agreement or any document furnished by the Party in connection with its performance under this Agreement obligate the State to (1) defend or indemnify the Party or any third party, or (2) otherwise be liable for the expenses or reimbursement, including attorneys’ fees, collection costs or other costs of the Party or any third party.

8. Insurance: Before commencing work on this Agreement the Party must provide certificates of insurance to show that the following minimum coverages are in effect. It is the responsibility of the Party to maintain current certificates of insurance on file with the State through the term of this Agreement. No warranty is made that the coverages and limits listed

herein are adequate to cover and protect the interests of the Party for the Party's operations. These are solely minimums that have been established to protect the interests of the State.

Workers Compensation: With respect to all operations performed, the Party shall carry workers' compensation insurance in accordance with the laws of the State of Vermont. Vermont will accept an out-of-state employer's workers' compensation coverage while operating in Vermont provided that the insurance carrier is licensed to write insurance in Vermont and an amendatory endorsement is added to the policy adding Vermont for coverage purposes. Otherwise, the party shall secure a Vermont workers' compensation policy, if necessary to comply with Vermont law.

General Liability and Property Damage: With respect to all operations performed under this Agreement, the Party shall carry general liability insurance having all major divisions of coverage including, but not limited to:

Premises - Operations

Products and Completed Operations

Personal Injury Liability

Contractual Liability

The policy shall be on an occurrence form and limits shall not be less than:

\$1,000,000 Each Occurrence

\$2,000,000 General Aggregate

\$1,000,000 Products/Completed Operations Aggregate

\$1,000,000 Personal & Advertising Injury

Automotive Liability: The Party shall carry automotive liability insurance covering all motor vehicles, including hired and non-owned coverage, used in connection with the Agreement. Limits of coverage shall not be less than \$500,000 combined single limit. If performance of this Agreement involves construction, or the transport of persons or hazardous materials, limits of coverage shall not be less than \$1,000,000 combined single limit.

Additional Insured. The General Liability and Property Damage coverages required for performance of this Agreement shall include the State of Vermont and its agencies, departments, officers and employees as Additional Insureds. If performance of this Agreement involves construction, or the transport of persons or hazardous materials, then the required Automotive Liability coverage shall include the State of Vermont and its agencies, departments, officers and employees as Additional Insureds. Coverage shall be primary and non-contributory with any other insurance and self-insurance.

Notice of Cancellation or Change. There shall be no cancellation, change, potential exhaustion of aggregate limits or non-renewal of insurance coverage(s) without thirty (30) days written prior written notice to the State.

9. Reliance by the State on Representations: All payments by the State under this Agreement will be made in reliance upon the accuracy of all representations made by the Party in accordance with this Agreement, including but not limited to bills, invoices, progress reports and other proofs of work.

10. False Claims Act: The Party acknowledges that it is subject to the Vermont False Claims Act as set forth in 32 V.S.A. § 630 *et seq.* If the Party violates the Vermont False Claims Act it shall be liable to the State for civil penalties, treble damages and the costs of the investigation and prosecution of such violation, including attorney's fees, except as the same may be reduced by a court of competent jurisdiction. The Party's liability to the State under the False Claims Act shall not be limited notwithstanding any agreement of the State to otherwise limit Party's liability.

11. Whistleblower Protections: The Party shall not discriminate or retaliate against one of its employees or agents for disclosing information concerning a violation of law, fraud, waste, abuse of authority or acts threatening health or safety, including but not limited to allegations concerning the False Claims Act. Further, the Party shall not require such employees or agents to forego monetary awards as a result of such disclosures, nor should they be required to report misconduct to the Party or its agents prior to reporting to any governmental entity and/or the public.

12. Location of State Data: No State data received, obtained, or generated by the Party in connection with performance under this Agreement shall be processed, transmitted, stored, or transferred by any means outside the continental United States, except with the express written permission of the State.

13. Records Available for Audit: The Party shall maintain all records pertaining to performance under this agreement. "Records" means any written or recorded information, regardless of physical form or characteristics, which is produced or

acquired by the Party in the performance of this agreement. Records produced or acquired in a machine readable electronic format shall be maintained in that format. The records described shall be made available at reasonable times during the period of the Agreement and for three years thereafter or for any period required by law for inspection by any authorized representatives of the State or Federal Government. If any litigation, claim, or audit is started before the expiration of the three-year period, the records shall be retained until all litigation, claims or audit findings involving the records have been resolved.

14. Fair Employment Practices and Americans with Disabilities Act: Party agrees to comply with the requirement of 21 V.S.A. Chapter 5, Subchapter 6, relating to fair employment practices, to the full extent applicable. Party shall also ensure, to the full extent required by the Americans with Disabilities Act of 1990, as amended, that qualified individuals with disabilities receive equitable access to the services, programs, and activities provided by the Party under this Agreement.

15. Set Off: The State may set off any sums which the Party owes the State against any sums due the Party under this Agreement; provided, however, that any set off of amounts due the State of Vermont as taxes shall be in accordance with the procedures more specifically provided hereinafter.

16. Taxes Due to the State:

- A. Party understands and acknowledges responsibility, if applicable, for compliance with State tax laws, including income tax withholding for employees performing services within the State, payment of use tax on property used within the State, corporate and/or personal income tax on income earned within the State.
- B. Party certifies under the pains and penalties of perjury that, as of the date this Agreement is signed, the Party is in good standing with respect to, or in full compliance with, a plan to pay any and all taxes due the State of Vermont.
- C. Party understands that final payment under this Agreement may be withheld if the Commissioner of Taxes determines that the Party is not in good standing with respect to or in full compliance with a plan to pay any and all taxes due to the State of Vermont.
- D. Party also understands the State may set off taxes (and related penalties, interest and fees) due to the State of Vermont, but only if the Party has failed to make an appeal within the time allowed by law, or an appeal has been taken and finally determined and the Party has no further legal recourse to contest the amounts due.

17. Taxation of Purchases: All State purchases must be invoiced tax free. An exemption certificate will be furnished upon request with respect to otherwise taxable items.

18. Child Support: (Only applicable if the Party is a natural person, not a corporation or partnership.) Party states that, as of the date this Agreement is signed, he/she:

- A. is not under any obligation to pay child support; or
- B. is under such an obligation and is in good standing with respect to that obligation; or
- C. has agreed to a payment plan with the Vermont Office of Child Support Services and is in full compliance with that plan.

Party makes this statement with regard to support owed to any and all children residing in Vermont. In addition, if the Party is a resident of Vermont, Party makes this statement with regard to support owed to any and all children residing in any other state or territory of the United States.

19. Sub-Agreements: Party shall not assign, subcontract or subgrant the performance of this Agreement or any portion thereof to any other Party without the prior written approval of the State. Party shall be responsible and liable to the State for all acts or omissions of subcontractors and any other person performing work under this Agreement pursuant to an agreement with Party or any subcontractor.

In the case this Agreement is a contract with a total cost in excess of \$250,000, the Party shall provide to the State a list of all proposed subcontractors and subcontractors' subcontractors, together with the identity of those subcontractors' workers compensation insurance providers, and additional required or requested information, as applicable, in accordance with Section 32 of The Vermont Recovery and Reinvestment Act of 2009 (Act No. 54).

Party shall include the following provisions of this Attachment C in all subcontracts for work performed solely for the State of Vermont and subcontracts for work performed in the State of Vermont: Section 10 ("False Claims Act"); Section 11 ("Whistleblower Protections"); Section 12 ("Location of State Data"); Section 14 ("Fair Employment Practices and

Americans with Disabilities Act”); Section 16 (“Taxes Due the State”); Section 18 (“Child Support”); Section 20 (“No Gifts or Gratuities”); Section 22 (“Certification Regarding Debarment”); Section 30 (“State Facilities”); and Section 32.A (“Certification Regarding Use of State Funds”).

20. No Gifts or Gratuities: Party shall not give title or possession of anything of substantial value (including property, currency, travel and/or education programs) to any officer or employee of the State during the term of this Agreement.

21. Copies: Party shall use reasonable best efforts to ensure that all written reports prepared under this Agreement are printed using both sides of the paper.

22. Certification Regarding Debarment: Party certifies under pains and penalties of perjury that, as of the date that this Agreement is signed, neither Party nor Party’s principals (officers, directors, owners, or partners) are presently debarred, suspended, proposed for debarment, declared ineligible or excluded from participation in Federal programs, or programs supported in whole or in part by Federal funds.

Party further certifies under pains and penalties of perjury that, as of the date that this Agreement is signed, Party is not presently debarred, suspended, nor named on the State’s debarment list at: <http://bgs.vermont.gov/purchasing/debarment>

23. Conflict of Interest: Party shall fully disclose, in writing, any conflicts of interest or potential conflicts of interest.

24. Confidentiality: Party acknowledges and agrees that this Agreement and any and all information obtained by the State from the Party in connection with this Agreement are subject to the State of Vermont Access to Public Records Act, 1 V.S.A. § 315 et seq.

25. Force Majeure: Neither the State nor the Party shall be liable to the other for any failure or delay of performance of any obligations under this Agreement to the extent such failure or delay shall have been wholly or principally caused by acts or events beyond its reasonable control rendering performance illegal or impossible (excluding strikes or lock-outs) (“Force Majeure”). Where Force Majeure is asserted, the nonperforming party must prove that it made all reasonable efforts to remove, eliminate or minimize such cause of delay or damages, diligently pursued performance of its obligations under this Agreement, substantially fulfilled all non-excused obligations, and timely notified the other party of the likelihood or actual occurrence of an event described in this paragraph.

26. Marketing: Party shall not refer to the State in any publicity materials, information pamphlets, press releases, research reports, advertising, sales promotions, trade shows, or marketing materials or similar communications to third parties except with the prior written consent of the State.

27. Termination:

A. Non-Appropriation: If this Agreement extends into more than one fiscal year of the State (July 1 to June 30), and if appropriations are insufficient to support this Agreement, the State may cancel at the end of the fiscal year, or otherwise upon the expiration of existing appropriation authority. In the case that this Agreement is a Grant that is funded in whole or in part by Federal funds, and in the event Federal funds become unavailable or reduced, the State may suspend or cancel this Grant immediately, and the State shall have no obligation to pay Subrecipient from State revenues.

B. Termination for Cause: Either party may terminate this Agreement if a party materially breaches its obligations under this Agreement, and such breach is not cured within thirty (30) days after delivery of the non-breaching party’s notice or such longer time as the non-breaching party may specify in the notice.

C. Termination Assistance: Upon nearing the end of the final term or termination of this Agreement, without respect to cause, the Party shall take all reasonable and prudent measures to facilitate any transition required by the State. All State property, tangible and intangible, shall be returned to the State upon demand at no additional cost to the State in a format acceptable to the State.

28. Continuity of Performance: In the event of a dispute between the Party and the State, each party will continue to perform its obligations under this Agreement during the resolution of the dispute until this Agreement is terminated in accordance with its terms.

29. No Implied Waiver of Remedies: Either party's delay or failure to exercise any right, power or remedy under this Agreement shall not impair any such right, power or remedy, or be construed as a waiver of any such right, power or remedy. All waivers must be in writing.

30. State Facilities: If the State makes space available to the Party in any State facility during the term of this Agreement for purposes of the Party's performance under this Agreement, the Party shall only use the space in accordance with all policies and procedures governing access to and use of State facilities which shall be made available upon request. State facilities will be made available to Party on an "AS IS, WHERE IS" basis, with no warranties whatsoever.

31. Requirements Pertaining Only to Federal Grants and Subrecipient Agreements: If this Agreement is a grant that is funded in whole or in part by Federal funds:

- A. Requirement to Have a Single Audit:** The Subrecipient will complete the Subrecipient Annual Report annually within 45 days after its fiscal year end, informing the State of Vermont whether or not a Single Audit is required for the prior fiscal year. If a Single Audit is required, the Subrecipient will submit a copy of the audit report to the granting Party within 9 months. If a single audit is not required, only the Subrecipient Annual Report is required. For fiscal years ending before December 25, 2015, a Single Audit is required if the subrecipient expends \$500,000 or more in Federal assistance during its fiscal year and must be conducted in accordance with OMB Circular A-133. For fiscal years ending on or after December 25, 2015, a Single Audit is required if the subrecipient expends \$750,000 or more in Federal assistance during its fiscal year and must be conducted in accordance with 2 CFR Chapter I, Chapter II, Part 200, Subpart F. The Subrecipient Annual Report is required to be submitted within 45 days, whether or not a Single Audit is required.
- B. Internal Controls:** In accordance with 2 CFR Part II, §200.303, the Party must establish and maintain effective internal control over the Federal award to provide reasonable assurance that the Party is managing the Federal award in compliance with Federal statutes, regulations, and the terms and conditions of the award. These internal controls should be in compliance with guidance in "Standards for Internal Control in the Federal Government" issued by the Comptroller General of the United States and the "Internal Control Integrated Framework", issued by the Committee of Sponsoring Organizations of the Treadway Commission (COSO).
- C. Mandatory Disclosures:** In accordance with 2 CFR Part II, §200.113, Party must disclose, in a timely manner, in writing to the State, all violations of Federal criminal law involving fraud, bribery, or gratuity violations potentially affecting the Federal award. Failure to make required disclosures may result in the imposition of sanctions which may include disallowance of costs incurred, withholding of payments, termination of the Agreement, suspension/debarment, etc.

32. Requirements Pertaining Only to State-Funded Grants:

- A. Certification Regarding Use of State Funds:** If Party is an employer and this Agreement is a State-funded grant in excess of \$1,001, Party certifies that none of these State funds will be used to interfere with or restrain the exercise of Party's employee's rights with respect to unionization.
- B. Good Standing Certification (Act 154 of 2016):** If this Agreement is a State-funded grant, Party hereby represents: (i) that it has signed and provided to the State the form prescribed by the Secretary of Administration for purposes of certifying that it is in good standing (as provided in Section 13(a)(2) of Act 154) with the Agency of Natural Resources and the Agency of Agriculture, Food and Markets, or otherwise explaining the circumstances surrounding the inability to so certify, and (ii) that it will comply with the requirements stated therein.

(End of Standard Provisions)

Appendix F: Procurement RFPs

REQUEST FOR ELECTRIC SCHOOL BUS PROPOSALS

This is a procurement conducted by the Champlain Valley School District, with support from VEIC, referred to here as the “Procuring Agency,” for the purchase of two (2) battery electric school buses: 1 - 77 passenger Type C and 1 - 90 passenger Type D, that meet Federal Motor Vehicle Safety Standards (FMVSS), requirements of the State of Vermont and requirements of the National School Transportation Specifications and Procedures in effect on date of manufacture. All other specifications are attached.

The Procuring Agency is seeking proposals for the purchase of battery electric school buses as part of an electric bus pilot program, supported by the Volkswagen Environmental Mitigation Trust (EMT) and led by the Vermont Department of Environmental Conservation (DEC). The pilot, administered by VEIC, will evaluate: the feasibility and cost-effectiveness of electric buses and electric vehicle supply equipment (EVSE) operating under conditions comparable to conventional diesel-powered buses (i.e., year-round under a full range of route conditions and settings, such as rural and urban routes, dirt roads, hilly conditions, etc.) in the state; as well as quantify the reduction in NOX and greenhouse gas emissions as described in the state’s [Beneficiary Mitigation Plan](#) for the Volkswagen EMT. Findings from the pilot will be used to encourage and inform future electric school bus purchases by Vermont school districts and school bus contractors operating in Vermont.

The Procuring Agency will elect to purchase buses pursuant to this procurement and will enter into contracts or purchase orders directly with the successful proposer. Selected vendor must comply with the State of Vermont’s contract provisions included here as **Attachment C: Standard State Provisions**.

Procurement Schedule:

July 2, 2020	RFP Issued
July 16, 2020	Deadline for Receipt of Questions in Writing to VEIC
July 23, 2020	Questions Responses
August 6, 2020	Proposals Due (4:00pm)
August 27, 2020	Anticipated Contract Award

All questions and clarifications regarding this request for proposals (RFP) must be made in writing, via email. Telephone questions are not permitted. All questions must be received via email by **July 16, 2020**. All correspondence regarding this RFP shall be submitted via email to:

Kate Cahalane, VEIC
kcahalane@veic.org

Electronic copies of proposals (including scanned copies of any documents requiring signature of proposer) must be received by VEIC via email to Kate Cahalane (kcahalane@veic.org) by 4:00pm on **August 6, 2020**. Proposals received after the date and time specified above shall be considered late proposals and therefore, shall not be considered for award. Proposals should be sent with the subject line: *RFP for Battery Electric School Buses*.

Proposal Details

Selection

In determining the successful bidder, consideration will be given to: price; financial responsibility of the bidder; responsiveness to specifications; strength of warranties; proposed delivery date and ability to meet delivery schedule; and the bidder's experience with electric vehicle technology including ability to demonstrate experience manufacturing electric school buses and experience of those vehicles in operation, ability to offer fully manufactured vehicles, and proven ability with cold weather operations.

The Procuring Agency reserves the right to accept any bid or reject any bid or all bids or to award the contract on such basis as the Procuring Agency deems to be in its best interest.

Taxes

The Procuring Agency is exempt from payment of federal, state and local taxes. Therefore, taxes should not be included in the proposed prices that are submitted.

Workmanship

Workmanship throughout shall conform to the highest standard of commercially accepted practice for the class of work and shall result in a neat and finished appearance.

Bids

Bids will be accepted as follows:

Chassis and body combined: QTY: 1 - 77 passenger and 1 - 90 passenger

Submitted using the attached **Bid Form**.

Required Documents and Publications

Documents Furnished with Proposal

Bidders are **required** to furnish with their bids:

1. Description of Bidder's experience in production of electric school buses
2. Documentation of Bidder's electric school bus deployments including quantities deployed, years deployed, estimated total miles driven, and two references from customers operating in similar conditions to Vermont (dirt roads, hilly conditions, winter weather, etc.)
3. Two years of financial statements demonstrating Bidder's financial stability
4. Detailed specifications as requested in **Specifications**, including explanation of any deviations from stated specifications
5. Chassis/body layout drawings
6. Appropriate warranties
7. A list of all Special Equipment (including parts numbers, color code, etc.) used on the chassis/body
8. Option Pricing
9. Special Tool Information: Bidder shall provide a list of special test equipment and tools required to maintain and repair systems down to the component level. For each special tool, the bidder shall provide:
 - a. Manufacturer part number
 - b. Detail of use/function
 - c. Purchase price for tool/equipment
10. Description of Training and Support to be provided and available to the Procuring Agency

Documents Furnished with Vehicles

Successful bidder is **required** to furnish the following items for each chassis/body that is purchased:

1. Application for certificate of title

2. Manufacturer's Statement of Origin
3. Operators manual
4. Warranty certificate covering chassis/body/motors/batteries as described herein
5. One (1) Parts and Service Repair Manual for body/chassis as a downloadable PDF file containing the required information. These files must contain an index with page numbers. Manual shall include parts and service information for conventional bus components as well as components specific to electric vehicles, i.e. traction batteries, AC/DC and DC/DC converters, traction motor, battery management system, etc.
6. One build sheet (line-setting ticket) including: all parts information relating to the chassis/body, to include all motor and power converter information including serial numbers, software versions, and battery information (chemistry, manufacturer, cell type, cells per pack, pack locations, serial numbers).
7. One operator's manual shall be provided for any special tool or piece of diagnostic equipment provided by the Bidder.

Warranty

Bidders should provide the terms of the base warranty (see: Warranty) as well as pricing and terms for optional extended battery and powertrain warranties (see: WARRANTY OPTIONS)

Training

Bidders should describe training included with the buses, including driver and mechanical maintenance and repair training, and the number of hours anticipated to conduct the training.

At a minimum, training shall include:

- In-person, post-delivery driver training for safety, instruments, control systems and range maximization
- In-person, post-delivery mechanic training for electric-vehicle-specific systems. Mechanic training shall include high voltage safety training, component location, access, and identification, and diagnostic system interface.

Support

Bidders shall describe technical support resources that will be available to the Procuring Agency. Specifically, if a mechanic has technical questions about the bus, who will be available to answer those questions, at what times will that resource be available, and how quickly will calls be returned?

Bidders shall describe the physical location and expected travel time of its nearest available mechanics who are experienced with its electric bus products and can be dispatched in the event that dealer maintenance is required at the Procuring Agency's site.

Component Availability

Bidders shall guarantee that chassis offered are current models, that assembly parts are in production for use in new chassis/body and that their manufacture and sale through dealer source will not be discontinued within ten years.

Bidder shall describe the location of its nearest parts distributor that is capable of supplying EV-specific parts for the proposed buses.

Prior Experience

Bidders shall describe their experience in providing 70+ passenger electric school buses that comply with all applicable regulations and laws of the State of Vermont and the United States Department of Transportation.

The names, addresses, contact persons, email addresses and telephone numbers of at least two prior organizations that have purchased and presently operate one or more of the bidder's 70+ passenger electric school buses should be included in this proposal.

Weather Protection

All dash instruments, horn button, power switch, etc. of the chassis shall be adequately protected against weather while the chassis is in storage.

Bid Form

THIS FORM MUST BE SUBMITTED WITH THE BID AND SIGNED ACCORDINGLY

Date: _____

Proposal of: _____

Hereinafter called "Bidder", a (corporation) (partnership) (circle one)

Of the State of _____

To: Champlain Valley School District;

The Bidder, in compliance with the Request for Proposals, having examined the specifications hereby proposes to furnish the buses in accordance with the attached specifications, and any exceptions to the specifications will be clearly identified. The Bidder also understands that failure to adhere to these specifications unless otherwise noted, may result in the bid not being considered.

The undersigned, as Bidder, declare the only person or parties interested in this Proposal as principals are those named herein; that this Proposal is made without collusion with any other firm, and the undersigned will take in full payment.

Total Lump Sum Base Bid Amount for two buses: 1 - 77 passenger and 1 - 90 passenger

_____ Dollars

Base Bid Written Amount

_____ Dollars

Base Bid Numerical Amount

MODEL YEAR _____

Option Pricing

Please provide Option Pricing for the below components for each vehicle requested.

Chassis Options

ITEMIZED PRICE FOR OPTIONS (Enter \$0 if provided as standard.)

BATTERY, LOW VOLTAGE

Heavy duty package \$ _____

BATTERY, TRACTION

Up to three additional traction battery configuration options to provide extra range. Each option to specify increased usable traction battery capacity in kWh, increased traction battery weight, and estimated increased nominal range.

Expanded Traction Battery Option A \$ _____
Increased usable capacity (kWh) _____
Increased battery weight _____
Estimated increased nominal range _____

Expanded Traction Battery Option B \$ _____
Increased usable capacity (kWh) _____
Increased battery weight _____
Estimated increased nominal range _____

Expanded Traction Battery Option C \$ _____
Increased usable capacity (kWh) _____
Increased battery weight _____
Estimated increased nominal range _____

CHARGING, BIDIRECTIONAL

If bidirectional charging is available, bidder shall specify itemized costs. These additional costs include proprietary electric vehicle supply equipment (EVSE) or control software that is required for bidirectional charging and any subscription service required for bidirectional charging. If DC fast charging option is required for bidirectional charging, bidder should NOT include the cost of the separate DC fast charging option in the cost of the bidirectional charging option.

Vehicle Bidirectional Charging Capability \$ _____
Required Proprietary EVSE \$ _____
Required Proprietary Control Software \$ _____
Required Annual Subscription Costs \$ _____

Bidder shall also describe: EVSE requirements to allow for bidirectional charging; bidirectional charging power limitations in kilowatts; bidirectional charging implications for battery warranty; and bidirectional charging control system and options for integration with possible future Vermont utility programs.

CHARGING, DC

If a DC charging option(s) is available, specify maximum charge rate in kW and expected charge times from 20% SOC to 90% SOC for each charging option.

If proprietary EVSE is required for DC charging, bidder must provide complete pricing, technical specifications, and warranty information for required EVSE.

Vehicle DC charging capability via SAE-Combo \$ _____
Maximum charge rate, kW _____
Expected charge time (20% SOC to 90% SOC) _____

Vehicle DC charging capability via other plug type (if applicable) \$ _____
Maximum charge rate, kW _____
Expected charge time (20% SOC to 90% SOC) _____
Plug Standard _____
Required EVSE \$ _____

CROSSING ARM \$ _____

CRUISE CONTROL \$ _____

STEERING

Tilt or tilt/telescope option may be either manual or power activated (Please specify in price list)

Tilt steering only \$ _____
Manual or power activated _____

Tilt with telescoping column \$ _____
Manual or power activated _____

TELEMATICS

Cloud-connected telematics system with data export option in Excel format. Minimum of two user licenses. At a minimum, telematics system should record the following data summarized not less frequently than daily: odometer; energy received from EVSE (kWh); net energy discharged from battery after regenerative braking; time stamps for EVSE connection and disconnection; and fault codes.

Telematics system \$ _____

Bidder shall also describe: the mode of data transfer from bus to cloud (cellular network(s), WiFi, or other); the available data interval for each of the data points above, if more frequency intervals than daily; and a complete list of downloadable data points, if more data points than those listed above are recorded.

TIRES

Spare Tire \$ _____

WARRANTY OPTIONS

EXTENDED TRACTION BATTERY WARRANTY

Extended warranty for 12 years / 200,000 miles including extended warranted battery degradation curve, cycle limits, and any other conditions that may differ from standard warranty

\$ _____

EXTENDED TRACTION MOTOR WARRANTY

Extended warranty for 10 years / 100,000 miles

\$ _____

Body Options

ALTERNATIVE HEATING SYSTEM(S)

Up to three viable alternative heating system option(s) to replace the default oil-fired heat. For example, electric resistance, electric heat pump, propane, etc. At least one alternative is required. *Bidders are strongly encouraged to include a propane-fired heating alternative.*

For each option, provide details on heating capacity, fuel storage, expected bus range implications, direct Criteria Air Pollutant (NOx and PM) emissions per unit of fuel, and hourly energy or fuel consumption at varying low ambient temperatures.

Alternative systems are expected to meet all applicable specifications under HEATING SYSTEM below.

Alternative Heating System Option A \$ _____

Type _____

Heating capacity _____

Fuel storage _____

Expected bus range implications _____

NOx emissions per unit of fuel _____

PM emissions per unit of fuel _____

Energy or fuel consumption _____

Alternative Heating System Option B (If Applicable) \$ _____

Type _____

Heating capacity _____

Fuel storage _____

Expected bus range implications _____

NOx emissions per unit of fuel _____

PM emissions per unit of fuel _____

Energy or fuel consumption _____

Alternative Heating System Option C (If Applicable) \$ _____

Type _____

Heating capacity _____

Fuel storage _____

Expected bus range implications _____

NOx emissions per unit of fuel _____

PM emissions per unit of fuel _____

Energy or fuel consumption _____

AUDIO SYSTEM

One or more of Aux/USB/Bluetooth (include description)

Description _____ \$ _____

DRIVER'S SEAT STORAGE

Stanchion cover with pocket storage behind driver's seat \$ _____

PAINT COLOR

Wheels to be painted blue \$ _____
Roof to be painted white \$ _____

SECOND ROOF HATCH

With vent. Only if hatch not required to meet FMVSS formula. If required, include in base price and enter \$0 option price \$ _____

SEAT, DRIVER'S

Heavy Duty Driver's Seat \$ _____

SNOW RAIL

\$ _____

STORAGE COMPARTMENTS

Double luggage compartments between wheels, curb side, 16" high by 28" deep by 85" in length \$ _____

STORAGE RACKS

22" parcel racks. Must meet head protection requirements in FMVSS 222. Front half of bus only. \$ _____

WHEELCHAIR CONFIGURATION

Wheelchair lift capacity of 1,000 pounds with easy-to-use tie downs. Seat configuration for one wheelchair station. Also shoulder and seat belts for each station. Quick release system for each set and storage bags near each station. Lift door on right side. Bidder to specify lift make and model.

Lift make \$ _____
Lift model _____

WIPERS

Heated option \$ _____

Bidder Acknowledgement

If the successful bidder (Contractor) fails to deliver the bus within the time schedule specified herein, or if the Contractor delivers a bus that does not conform to all of the provisions of Specifications provided here, the Procuring Agency may, by written notice of default to the Contractor, terminate the whole or any part of agreed upon contract.

PLEASE SPECIFY YOUR ANTICIPATED DATE OF DELIVERY FOR THESE TWO UNITS:

The undersigned hereby acknowledges that he/she has read this proposal in its entirety and understands and agrees to all provisions contained herein.

Respectfully submitted:

(Firm Name)

By:

(Signature)

Firm Information

Company Name: _____

Contact Person: _____

Mailing Address: _____

Phone Number: _____

Fax Number: _____

Email Address: _____

NOTE: Bid Option Pricing for both vehicles should be attached to this sheet

Warranty

All warranty periods shall commence on date of acceptance of bus by the Procuring Agency.

Powertrain

Contractor shall warrant for five years or 100,000 miles (whichever comes first) the entire powertrain as applicable (traction motor(s), transmission, differential, drive shaft and bearings)

Traction Battery

Traction Battery shall be warranted for a minimum of six years or 100,000 miles (whichever comes first) against total failure or excessive capacity degradation.

Bidder shall provide a warranted Traction Battery capacity degradation curve for the duration of the warranty period. Warranted degradation curve shall indicate warranted capacity in kWh and in percent of initial rated capacity for each warranty year.

Bidder shall provide a comprehensive statement of the warranty terms relating to the Traction Battery, including explanation of all disclaimers within the warranty and procedures to determine battery degradation or failure for warranty claims.

Chassis

Contractor shall warrant onboard computer hardware and software systems, AC/DC, and DC/DC converters for five years and unlimited miles.

Contractor shall warrant all other chassis items for the manufacturer's standard warranty period.

Body

Contractor shall warrant heating systems and all interior and exterior paint for five years and unlimited miles.

Contractor shall warrant the body and all related items for the manufacturer's standard warranty period or two years, whichever is greater.

Specifications: Type C, 77-78 Passenger

NOTE: All School Buses as supplied must meet all relevant FMVSS, State of Vermont School Bus Standards, and Federal EPA Emissions Standards for the model year produced as a minimum unless a more stringent requirement is stated in the following specification.

Chassis Specifications

AXLE, FRONT

Min. 10,000 lbs. I-Beam type with 40-45 degree turning radius, parabolic front springs or equivalent, and oil bath hubs w/soft ride or equivalent as standard equipment. Springs to be equal in rating to axle.

AXLE, REAR

Certifiable for body configuration and capacity, 21,000 lbs. for 77 passengers; single speed only limited slip or traction control. Air ride if bus is equipped with an air compressor.

AXLE, REAR RATIO

Manufacturer's recommendation for range of service specified by Procuring Agency and for optimal performance of batteries/motor.

BATTERIES, LOW VOLTAGE

Minimum of one Group 31 battery shall be provided.

Low voltage battery system must be sized with sufficient reserve to allow operation of the 8-way warning light system, heating system, instrument cluster, and exterior lighting for 1 hour at 0 degrees Fahrenheit in the event of a failure of the of DC-DC converter or high voltage system.

Battery cables shall be long enough to allow full extension of battery tray. Battery cables to be color-coded red-positive/black-ground. NOTE: ANY WIRES PASSING THROUGH THE FRAME RAILS SHALL BE GROMMETED TO PREVENT CHAFING.

BRAKES

If hydraulic brakes are proposed, bidder shall provide detailed specifications of braking system components and a brief narrative explaining the reasoning behind the choice of hydraulic brakes.

If air brakes are proposed,

Dual air brake system with Bendix AD-9 Air Dryer with heater, 13.2 CFM Air Compressor. 15" x 4" Front and 16.5" x 7" rear.

Anti-Lock brake system, full vehicle wheel control system (4-channel), with dust shields front & rear.

BRAKING, REGENERATIVE

The bus shall employ a regenerative braking system to aid in the reduction of wear on the brakes and to help extend range through energy recapture.

The bus shall activate regenerative braking as the accelerator pedal is completely released. Regenerative braking shall be additionally increased as the brake pedal is applied.

Regenerative braking effort upon accelerator release and upon brake pedal pressure shall be independently adjustable.

Actuation of Anti-Lock Braking System (ABS) and / or Automatic Traction Control (ATC) shall override the operation of regenerative braking.

Driver shall be provided with a switch to disengage all regenerative braking.

The bus shall include a means of maintaining dynamic braking (braking retardation) as the ESS approaches 100% SOC.

CHARGING PORT

The bus shall accept a standard SAE J1772 or Type 1 CCS plug.

Bus shall not require use of proprietary EVSE or plug adapters unless DC charging option is selected.

DC/DC CONVERTER

The Traction Batteries shall maintain the charge on the low voltage batteries via a DC/DC converter. The bus shall be equipped with a 12 VDC DC-DC power converter with capacity suitably rated to handle all auxiliary electrical load requirements.

ENERGY STORAGE SYSTEM

The Energy Storage System (ESS) is comprised of the traction battery, high voltage wiring, traction battery charger, traction motor power supply, and all traction battery support and control systems.

The ESS design, including containers, module bracing systems, thermal-management systems, battery management systems, watering/venting systems, interconnections, fusing, and traction-controller and charger interfaces should be completely described in the proposal.

The ESS shall be capable of operating in ambient temperatures from -30F to 105F.

An overview of expected performance of the ESS at low ambient temperatures shall be provided, detailing expected bus range impacts of ambient temperatures down to -30F.

Traction Battery

Bidders should provide battery chemistry, make, and cell type information as well as the details below.

Performance

An overview of the design and performance of the Traction Battery shall be provided. This overview shall include manufacturer's predicted battery degradation curves, usable and total capacity, and battery cycle life. The traction battery shall employ established battery technology that has a field-proven track record of safe, reliable, and durable operation in similar applications.

Traction Battery Safety

The traction battery shall comply with UN/DOT 38.3 requirements for lithium batteries or similar standards for non-lithium batteries.

Proposals shall include descriptions of all safety standards followed in the design and manufacture of the battery system, safety testing procedures used to validate the safety of battery operation in this application, and documented results of safety testing to confirm that standards have been met. Bidders shall include certification of battery safety testing by independent testing agency.

The traction battery shall be located outside the passenger compartment and in a position outside of a direct side or rear impact zone. The traction battery shall be load distributed within the bus to equalize weight between the wheels on the same axles and to achieve appropriate weight distribution between axles so as not to adversely affect handling of the bus.

The bus body shall be purpose-designed and constructed to ensure passengers and the driver will not be exposed to electrical current either in normal operation or in the event of a collision. The ESS shall be designed and constructed to prevent gassing or fumes from the traction battery from entering the interior of the bus.

Traction Battery Life-Cycle

Proposals shall include descriptions of all life-cycle testing procedures used to validate the life of batteries used in this application at the proposed charging rates, charge durations, and expected ambient temperatures and operating profiles. Bidders shall include documented results of life cycle testing. Bidders shall include certification of battery life cycle testing by independent testing agency.

Bidder shall provide overview of battery life maximization strategies. This overview shall include automatic functions of the BMS that help to extend battery life, as well as recommended owner operation and maintenance practices that maximize battery life.

Traction Battery Charging System

Level 2 charging shall be accomplished without the need for a proprietary plug. (See CHARGING PORT)

DC charging to be provided as an option. (See CHARGING, DC)

Traction battery charging system shall be field-programmable by a mechanic to schedule charging hourly on a 7-day basis. I.e. the traction battery charging system may be programmed to not begin charging immediately upon connection to EVSE, but instead to charge on a scheduled basis.

All charging system components shall have UL approval certification or provide documentation that UL approval is in process. If UL approval is not available or process has not yet been begun, the bidder should provide documentation that UL certification process will be actively sought (i.e. demonstrate serious market intentions) during charging systems expected lifetime.

All charging system components, including the coupler/s, shall also meet or exceed the most current SAE Standards and comply with relevant IEEE standards.

Charging systems shall be capable of operating from -30F to 122F with no more than 10% degradation in specified performance.

Bidder shall provide documentation of peak and average power conversion efficiency for onboard inverter.

Bidder shall provide documentation of typical recharge time from 20% SOC to 90% SOC when connected to a 70- or 80-amp Level 2 EVSE.

Traction Battery Thermal Management

Battery thermal management must be powered from an onboard source. Thermal management must be continuously monitored with appropriate safety interlocks installed to react to adverse conditions.

Battery temperatures must never exceed the manufacturer's recommended range during operation in the design operating profile and specified ambient conditions. Battery cooling must prevent cell temperature from exceeding the battery manufacturer's recommended maximum when the ambient temperature is above 105F for a period of 16 hours.

Bidder shall provide an overview of the battery thermal management system, including design specifications, components, and theory of operation.

If batteries will be kept warm while the bus is connected to EVSE, bidder shall describe the controls for battery warming. Bidder shall describe the specific mode of warming, warming system capacity in BTU or kW, and estimated energy or fuel use per hour at 0F ambient temperature.

Traction Battery Management System (BMS)

At a minimum, the traction battery management system (BMS) must perform the following functions:

1. The BMS must be capable of monitoring the voltage level of cells within each battery pack. The BMS must read and store individual battery or block voltages at a frequency of 1 data point per block every 15 seconds. The system must also monitor battery pack temperatures using no fewer than 2 thermocouples placed in and around each battery pack sampled every 15 seconds.
2. The BMS must be capable of detecting when any battery fault (as defined by the battery manufacturer) has occurred, store data on the fault, and communicate this stored data to maintenance personnel.
3. The BMS must be capable of alerting the driver and engaging prudent safety interlocks when an unsafe battery condition has been detected.

4. The BMS must monitor the battery state-of charge and update a gauge on the dashboard at least once every 15 seconds.

FRAME

Manufacturer must certify frame dimensions and bending strength to body size and configurations.

FUEL TANK, AUXILIARY

15 gallons oil minimum, with locking access door. Fuel tank maintenance access panel in floor of cabin. Tank shall be equipped for at least a 93% draw.

HORN

Dual, electric.

INSTRUMENTS

At a minimum, the driver's instrument cluster shall include:

- Speedometer
- Odometer
- State of charge indicator
- Hour meter
- Auxiliary heater fuel tank gauge
- Estimated remaining range display
- Regenerative braking status indicator
- Warning light and buzzer for critical powertrain problems.
- No Child Left Behind (Alarm)

MOTOR, TRACTION

Bidder shall provide complete specifications for the traction motor.

When used in conjunction with the base traction battery option and the proposed wiring and power conversion systems, the traction motor shall be capable of achieving the vehicle performance requirements below.

Top Speed

Top bus speed must be governed and adjustable. The bus shall be mechanically capable of achieving a top speed of 70 mph on a straight, level road at GVWR with all accessories operating.

Acceleration

Acceleration requirements shall be met on dry commercial asphalt or concrete pavement at GVWR with all accessories operating.

The bus must accelerate to 10 miles per hour (mph) in four seconds; to 20 mph in 10 seconds; 30 mph in 20 seconds and 40 mph in 35 seconds.

Gradeability

Gradeability requirements shall be met on grades with a dry commercial asphalt or concrete pavement at GVWR with all accessories operating.

The bus must achieve a minimum speed of 40 mph on a 2.5% ascending grade and 15mph on a 10% ascending grade.

Maintenance

The traction motor shall be arranged so that accessibility for all routine maintenance is assured. No special tools, other than dollies and hoists, shall be required to remove the motor or any subsystems. Bidder shall describe all specialty tools and diagnostic equipment required for maintaining the traction motor.

Design Life

The traction motor shall be designed to operate for not less than 200,000 miles without major failure or significant deterioration. Components of the control system and power conversion system shall be designed to operate for not less than 100,000 miles without major failure.

PAINT

All paint shall be unleaded.

RANGE

Daily mileage requirement is expected to be approximately 40 miles in hilly terrain and sub-zero temperatures.

Bidder shall specify nominal bus range required to meet this operating profile, and the conditions under which this range would apply.

Bidder shall provide information to address the expected range impacts of hilly terrain, highway travel, and low-speed operation with frequent stops.

Bidder shall provide specific information on range loss in low ambient temperatures.

SHOCK ABSORBERS

Heavy duty, dual action rated to each axle.

STEERING

Full power steering.

SUSPENSION

Air ride if equipped with air compressor suspension, front, parabolic, taper: springs with shock absorbers.

TIRES

Six 10.R/22.5 tires. Tires provided installed. Full rated.

Front: 14 ply, Unisteel G-159 (or equivalent)

Rear: 14 ply Unisteel, G-124 traction tires, mud & snow (or equivalent)

TOW HOOKS

Two each, front and rear.

TRANSMISSION

If a transmission is used, synthetic fluid required. Fluid type must meet manufacturers specifications as contained in extended warranty requirements.

UNDERCOATING

Petroleum or wax base.

WHEELBASE

276 inches

WHEELS

20" cast wheels with 7.5" x 22.5" rims

YEAR, CURRENT MODEL

Bid must specify model year.

Body Specifications

BACK UP ALARM

Included. Must comply with published Back up Alarm Standards (SAE J994B) and provide a minimum of 107 dbA.

BODY STRUCTURE

If composite, aluminum, or other materials other than steel are proposed for body panels, bidder must provide justification for this choice and provide details of body construction.

Construction to meet or exceed FMVSS crash and rollover specifications. Construction must meet or exceed FMVSS and the National School Transportation Specifications & Procedures.

Steel body parts to be thoroughly rust proofed after fabrication.

For steel body panels: baked on polyurethane paint. Aluminized interior panels below side windows. 16-gauge steel side-walls.

Chip guard & door edge cowl skirt protection.

BUMPERS

Front and rear: blue (heavy duty)

COWLING MATERIAL

Fiberglass or equal. (May not be needed on all manufacturer. Bid according to manufacturer recommendation)

CRASH PADS/BARRIERS

Per FMVSS

DOORS, EMERGENCY AND EXIT

Latch buzzer rear.

Center mounted inside and outside handles.

Upper and lower panels of approved safety glass.

Number and design of all emergency exits must meet FMVSS No. 217.

Exterior access handles on all emergency doors must include a 6" directional arrow showing direction of movement to release/open the door.

Vandal lock and wired to prevent vehicle motion when locked.

See ROOF ESCAPE HATCH for additional emergency exit information.

DOOR, SERVICE

All doors shall be equipped with padding at the top edge of each door opening. Padding shall be at least three inches wide and one inch thick and extend the full width of the door opening. All door hinges must be equipped with grease fittings or lubrication ports.

Air operated with regulatory limiting valve.

Two leaf, outward opening, with windows top and bottom.

Entrance door equipped with security lock and entrance door windows to be thermo-pane standard. Red/Amber/Door opening switches mounted on left side of driver.

ENTRANCE

4-Step (3-steps & the 4th step is actually the floor inside of bus). Riser should be calculated by the mfg. consistent w/the related FMVSS, frame rail height and tire size.

FLOORS

Heavy Duty rubber covering, 16" ribbed tread on entrance steps, and 13" on aisles. Rear wheel houses and area under seats to be completely covered with smooth rubber mat. All seams to be bonded and smooth.

SUB-FLOOR: 5/8 inch marine or equivalent plywood. (Premium grade exterior plywood acceptable) Plywood to be screwed to sub-floor with all exposed edges sealed.

FUEL TANK ACCESS

Right side fill access, with spring loaded hinge and lock. Fuel tank sending unit access cover plate in bus floor.

HEADROOM

77" inches standard

HEATING SYSTEM

Bidder must include a complete description of the heating system, including heating source specifications, direct Criteria Air Pollutant (NOx and PM) emissions per unit of fuel, hourly fuel consumption at varying low ambient temperatures and emitter capacities and locations.

Heating system must maintain the bus interior temperatures as specified in SAE test procedure J2233 *without the use of supplemental electric resistance heat.*

System must include accessible bleeder valves appropriately placed in the return lines to remove air from hydronic heater lines.

Set of two (2) 6" overhead fans shall be provided to assist in both defrosting and cooling with installation not to restrict visibility.

Heat Source

Oil-fired heating system as standard (provide alternative(s) as options)

Rear exhaust. Top-rear exhaust preferred.

Emitters

All heater cores to be copper tube coil design with aluminum fins.

- Driver heater
- Stepwell heater/defroster
- Defroster with channel shall run full length of windshield
- Set of two 6" overhead fans shall be provided to assist in both defrosting and cooling w/ installation not to restrict visibility.
- Heating system must be of sufficient capability to maintain the bus interior temperatures as specified in SAE test procedure J2233.
- System must include accessible bleeder valves appropriately placed in the return lines to remove air from the heater fluid lines, if equipped.
- Must maintain comfortable interior temperatures in sub-zero weather.

INSULATION

Fire resistant and UL approved.

R factor of at least 6.25 in sidewall, roof, front and rear quarter sections including roof bows.

Insulate driver's area.

Acoustical ceiling panels full length of bus.

LETTERING

“School Bus” must be not less than 6” high, located between the warning signal lamps, front and rear. All other lettering will be placed on the left and right sides of the vehicle as specified by the Procuring Agency after award. Also, up to five (5) digit letter-number code will be placed on left and right front cowls, and rear of bus, 6” high.

LIGHTS, EXTERIOR

BACK-UP, WARNING: LED standard 7” dual clear.

WARNING: 8-light system/strobing LED with light monitoring system

LIGHTS, INTERIOR

Passenger & driver’s dome lights with separate switch for driver’s dome.

ADA Compliant walk and step well light to be wired to activate with entrance door control.

Red ICC tell-tale lights over emergency door loading areas.

MINIMUM SOUND

Vehicle shall adhere to minimum sound requirements for light vehicles as stated in FMVSS 141, unless that standard is superseded for vehicles of this weight class.

MIRRORS, INSIDE

6” x 30”; Rear View

MIRRORS, OUTSIDE

Two each left and right rear view mirrors.

All exterior mirrors heated as standard equipment.

MUD FLAPS

Front each wheel and rear each wheel.

PASSENGER CAPACITY

Within the 77-78 range. Reduced seating options must not exceed FMVSS maximum seat spacing and barrier requirements.

POWER PORT

12-volt DC power port in driver’s area

RADIOS

AM/FM/CD player/PA; inside/outside speaker; 6 roof-mounted speakers inside. Dash-mounted, hand-held microphone.

One AM/FM antenna on driver’s side.

Two-way radio option from dealer provided selection.

RAILS

Three exterior rails at or near bottom of window line, seat cushion line and floor line.

ROOF ESCAPE HATCH

Open-hatch warning buzzer as standard.

Minimum five (5) year warranty for installation, workmanship, materials and leaks.

One roof mounted, ventilated escape hatch; second roof escape hatch if required to meet FMVSS formula.

TRANSPEC models 1900, 1925 or Specialty model 8645, or equivalent

SAFETY EQUIPMENT

First Aid Kit per National School Transportation Specifications and Procedures Manual (NSTSP)

Body Fluid Kit

Three Safety Triangles with secure on-board storage

Belt Cutter: A Tie-Tech belt cutter shall be installed in the Safety Equipment storage box.

Fire Extinguisher: 5# min. dry type A-B-C

SEATING, DRIVER

If the bus is equipped with an air compressor, the driver's seat shall include air suspension.

The driver's seat shall be of a high-back type with a minimum seat back adjustment of fifteen (15) degrees and a head restraint accommodating sizes through ninety-five (95) percentile adult male (as defined in FMVSS 208).

The driver's seat shall have minimum distance between the steering wheel and the seat back not less than eleven inches (11") with a minimum aft adjustment of six inches (6").

The driver's seat shall provide for fore-and-aft and up and down adjustment and shall be contoured with adequate support on the sides, including but not limited to arm rests.

Driver's station should be rearward so the seat can be moved back further.

Driver's seat shall be Bostrum #2239488-A78 or National Air Model 195 with arm rests.

A Type II seat belt with adjustable lap-shoulder, ERL type w/3-point hitch.

SEATING, PASSENGER

Seat belts to be included and installed at time of manufacture. Forward facing, fully padded, 52 oz. upholstery. Not less than 13" per passenger seat width, sidewall to aisle. Minimum 12" aisle width per FMVSS.

SIGNAGE

Two inches wide by eight inches high reflective letters, front and rear school bus signs. 1.25 inch reflective tape to outline rear door, school bus sign and rear windows. Two-inch reflective stripe at top of floor level rub rail on each side of bus. Procuring Agency may request additional striping as an option not to exceed state or federal safety specifications and standards.

STOP SIGNAL ARM

One, driver controlled, hinged, swing-out type to meet FMVSS 131. Double faced, alternating flashing red lamps, one each mounted top and bottom of the stop sign. Sign(s) and lights automatically activate with the entrance door control.

SUNVISORS

Transparent plexiglass 6" x 30" front

WHEEL CHOCKS

Two each with tie downs and secure on-board storage

WINDOWS

Bids must meet or exceed State of Vermont Uniform School Bus Standard and bid specifications.

All passenger windows will be 12" minimum (both top and bottom). Side passenger windows (both top and bottom) will be minimum of 12" in height each.

Thermopane windows in the following locations:

- drivers sliding window
- service door windows
- first two passenger windows right side.

Only windshield shall be tinted. No side or door window tint options allowed.

WINDSHIELD

Standard flat, tinted (curved may be substituted if manufacturer's standard for the vehicle offered)

WIPERS

Both sides, electric, intermittent 2-speed, heavy duty motors, with washers.

Arctic all weather blades.

WIRING

All wiring shall conform to the standards of the Society of Automotive Engineers. It shall be color and number coded, insulated and protected by covering of fibrous loom, or equivalent covering. All fuse/circuit breaker blocks shall have circuit identification decals.

Wiring shall be clearly differentiated by color: 12VDC, high voltage DC, and AC.

Specifications: Type D, 90 Passenger

NOTE: All School Buses as supplied must meet all relevant FMVSS, State of Vermont School Bus Standards, and Federal EPA Emissions Standards for the model year produced as a minimum unless a more stringent requirement is stated in the following specification.

Chassis Specifications

AXLE, FRONT

Min. 13,200lbs. I-Beam type with 40-45 degree turning radius, parabolic front springs or equivalent & oil bath hubs w/soft ride or equivalent as standard equipment. Springs to be equal in rating to axle. Air ride front.

AXLE, REAR

Certifiable for body configuration and capacity, air ride (if equipped with air compressor) rear axle 23,000 lbs. for 90 passenger; single speed only, limited slip and/or traction control.

AXLE, REAR RATIO

Manufacturer's recommendation for range of service specified by Procuring Agency and for optimal performance of batteries/motor.

BATTERIES, LOW VOLTAGE

Minimum of one Group 31 battery shall be provided.

Low voltage battery system must be sized with sufficient reserve to allow operation of the 8-way warning light system, heating system, instrument cluster, and exterior lighting for 1 hour at 0 degrees Fahrenheit in the event of a failure of the of DC-DC converter or high voltage system.

Battery cables shall be long enough to allow full extension of battery tray. Battery cables to be color-coded red-positive/black-ground. NOTE: ANY WIRES PASSING THROUGH THE FRAME RAILS SHALL BE GROMMETED TO PREVENT CHAFING.

BRAKES

If hydraulic brakes are proposed, bidder shall provide detailed specifications of braking system components and a brief narrative explaining the reasoning behind the choice of hydraulic brakes.

If air brakes are proposed,

Dual air brake system with Bendix AD-9 Air Dryer with heater, 13.2 CFM Air Compressor. FRT air 6" wide. Front and 16.5" x 7" rear. Bendix Anti-Lock brake system, full vehicle wheel control system (4-channel). Dust shields front & rear.

BRAKING, REGENERATIVE

The bus shall employ a regenerative braking system to aid in the reduction of wear on the brakes and to help extend range through energy recapture.

The bus shall activate regenerative braking as the accelerator pedal is completely released. Regenerative braking shall be additionally increased as the brake pedal is applied.

Regenerative braking effort upon accelerator release and upon brake pedal pressure shall be independently adjustable.

Actuation of Anti-Lock Braking System (ABS) and / or Automatic Traction Control (ATC) shall override the operation of regenerative braking.

Driver shall be provided with a switch to disengage all regenerative braking.

The bus shall include a means of maintaining dynamic braking (braking retardation) as the ESS approaches 100% SOC.

CHARGING PORT

The bus shall accept a standard SAE J1772 or Type 1 CCS plug.

Bus shall not require use of proprietary EVSE or plug adapters unless DC charging option is selected.

DC/DC CONVERTER

The Traction Batteries shall maintain the charge on the low voltage batteries via a DC/DC converter. The bus shall be equipped with a 12 VDC DC-DC power converter with capacity suitably rated to handle all auxiliary electrical load requirements.

ENERGY STORAGE SYSTEM

The Energy Storage System (ESS) is comprised of the traction battery, high voltage wiring, traction battery charger, traction motor power supply, and all traction battery support and control systems.

The ESS design, including containers, module bracing systems, thermal-management systems, battery management systems, watering/venting systems, interconnections, fusing, and traction-controller and charger interfaces should be completely described in the proposal.

The ESS shall be capable of operating in ambient temperatures from -30F to 105F.

An overview of expected performance of the ESS at low ambient temperatures shall be provided, detailing expected bus range impacts of ambient temperatures down to -30F.

Traction Battery

Bidders should provide battery chemistry, make, and cell type information as well as the details below.

Performance

An overview of the design and performance of the Traction Battery shall be provided. This overview shall include manufacturer's predicted battery degradation curves, usable and total capacity, and battery cycle life. The traction battery shall employ established battery technology that has a field-proven track record of safe, reliable, and durable operation in similar applications.

Traction Battery Safety

The traction battery shall comply with UN/DOT 38.3 requirements for lithium batteries or similar standards for non-lithium batteries.

Proposals shall include descriptions of all safety standards followed in the design and manufacture of the battery system, safety testing procedures used to validate the safety of battery operation in this application, and documented results of safety testing to confirm that standards have been met. Bidders shall include certification of battery safety testing by independent testing agency.

The traction battery shall be located outside the passenger compartment and in a position outside of a direct side or rear impact zone. The traction battery shall be load distributed within the bus to equalize weight between the wheels on the same axles and to achieve appropriate weight distribution between axles so as not to adversely affect handling of the bus.

The bus body shall be purpose-designed and constructed to ensure passengers and the driver will not be exposed to electrical current either in normal operation or in the event of a collision. The ESS shall be designed and constructed to prevent gassing or fumes from the traction battery from entering the interior of the bus.

Traction Battery Life-Cycle

Proposals shall include descriptions of all life-cycle testing procedures used to validate the life of batteries used in this application at the proposed charging rates, charge durations, and expected ambient temperatures and operating profiles. Bidders shall include documented results of life cycle testing. Bidders shall include certification of battery life cycle testing by independent testing agency.

Bidder shall provide overview of battery life maximization strategies. This overview shall include automatic functions of the BMS that help to extend battery life, as well as recommended owner operation and maintenance practices that maximize battery life.

Traction Battery Charging System

Level 2 charging shall be accomplished without the need for a proprietary plug. (See CHARGING PORT)

DC charging to be provided as an option. (See CHARGING, DC)

Traction battery charging system shall be field-programmable by a mechanic to schedule charging hourly on a 7-day basis. I.e. the traction battery charging system may be programmed to not begin charging immediately upon connection to EVSE, but instead to charge on a scheduled basis.

All charging system components shall have UL approval certification or provide documentation that UL approval is in process. If UL approval is not available or process has not yet been begun, the bidder should provide documentation that UL certification process will be actively sought (i.e. demonstrate serious market intentions) during charging systems expected lifetime.

All charging system components, including the coupler/s, shall also meet or exceed the most current SAE Standards and comply with relevant IEEE standards.

Charging systems shall be capable of operating from -30F to 122F with no more than 10% degradation in specified performance.

Bidder shall provide documentation of peak and average power conversion efficiency for onboard inverter.

Bidder shall provide documentation of typical recharge time from 20% SOC to 90% SOC when connected to a 70- or 80-amp Level 2 EVSE.

Traction Battery Thermal Management

Battery thermal management must be powered from an onboard source. Thermal management must be continuously monitored with appropriate safety interlocks installed to react to adverse conditions.

Battery temperatures must never exceed the manufacturer's recommended range during operation in the design operating profile and specified ambient conditions. Battery cooling must prevent cell temperature from exceeding the battery manufacturer's recommended maximum when the ambient temperature is above 105F for a period of 16 hours.

Bidder shall provide an overview of the battery thermal management system, including design specifications, components, and theory of operation.

If batteries will be kept warm while the bus is connected to EVSE, bidder shall describe the controls for battery warming. Bidder shall describe the specific mode of warming, warming system capacity in BTU or kW, and estimated energy or fuel use per hour at 0F ambient temperature.

Traction Battery Management System (BMS)

At a minimum, the traction battery management system (BMS) must perform the following functions:

1. The BMS must be capable of monitoring the voltage level of cells within each battery pack. The BMS must read and store individual battery or block voltages at a frequency of 1 data point per block every 15 seconds. The system must also monitor battery pack temperatures using no fewer than 2 thermocouples placed in and around each battery pack sampled every 15 seconds.
2. The BMS must be capable of detecting when any battery fault (as defined by the battery manufacturer) has occurred, store data on the fault, and communicate this stored data to maintenance personnel.
3. The BMS must be capable of alerting the driver and engaging prudent safety interlocks when an unsafe battery condition has been detected.

4. The BMS must monitor the battery state-of charge and update a gauge on the dashboard at least once every 15 seconds.

FRAME

Manufacturer must certify frame dimensions and bending strength to body size and configurations.

FUEL TANK, AUXILIARY

15 gallons oil minimum, with locking access door. Fuel tank maintenance access panel in floor of cabin. Tank shall be equipped for at least a 93% draw.

HORN

Dual, electric.

INSTRUMENTS

At a minimum, the driver's instrument cluster shall include:

- Speedometer
- Odometer
- State of charge indicator
- Hour meter
- Auxiliary heater fuel tank gauge
- Estimated remaining range display
- Regenerative braking status indicator
- Warning light and buzzer for critical powertrain problems.
- No Child Left Behind (Alarm)

MOTOR, TRACTION

Bidder shall provide complete specifications for the traction motor.

When used in conjunction with the base traction battery option and the proposed wiring and power conversion systems, the traction motor shall be capable of achieving the vehicle performance requirements below.

Top Speed

Top bus speed must be governed and adjustable. The bus shall be mechanically capable of achieving a top speed of 70 mph on a straight, level road at GVWR with all accessories operating.

Acceleration

Acceleration requirements shall be met on dry commercial asphalt or concrete pavement at GVWR with all accessories operating.

The bus must accelerate to 10 miles per hour (mph) in four seconds; to 20 mph in 10 seconds; 30 mph in 20 seconds and 40 mph in 35 seconds.

Gradeability

Gradeability requirements shall be met on grades with a dry commercial asphalt or concrete pavement at GVWR with all accessories operating.

The bus must achieve a minimum speed of 40 mph on a 2.5% ascending grade and 15mph on a 10% ascending grade.

Maintenance

The traction motor shall be arranged so that accessibility for all routine maintenance is assured. No special tools, other than dollies and hoists, shall be required to remove the motor or any subsystems. Bidder shall describe all specialty tools and diagnostic equipment required for maintaining the traction motor.

Design Life

The traction motor shall be designed to operate for not less than 200,000 miles without major failure or significant deterioration. Components of the control system and power conversion system shall be designed to operate for not less than 100,000 miles without major failure.

PAINT

All paint shall be unleaded.

RANGE

Daily mileage requirement is expected to be approximately 40 miles in hilly terrain and sub-zero temperatures.

Bidder shall specify nominal bus range required to meet this operating profile, and the conditions under which this range would apply.

Bidder shall address the expected range impacts of hilly terrain, highway travel, and low-speed operation with frequent stops.

Bidder shall provide specific information on range loss in low ambient temperatures.

SHOCK ABSORBERS

Heavy duty, dual action rated to each axle.

STEERING

Full power steering.

SUSPENSION

Air ride (if equipped with air compressor), Front & Rear, parabolic, taper, leaf: springs with shock absorbers.

TIRES

Six tires 11.00R/22.5, Tires provided installed. Full rated.

Front: 14 ply, Unisteel G-159 (or equivalent)

Rear: 14 ply Unisteel, G-124 traction tires.

TOW HOOKS

Two each, front and rear.

TRANSMISSION

If a transmission is used, synthetic fluid required. Fluid type must meet manufacturers specifications as contained in extended warranty requirements.

UNDERCOATING

Petroleum or wax base.

WHEELBASE

276 inches

WHEELS

8.25 x 22.5 Steel wheels – disc hub-piloted.

YEAR, CURRENT MODEL

Bid must specify model year.

Body Specifications

BACK UP ALARM

Included. Must comply with published Back up Alarm Standards (SAE J994B) and provide a minimum of 107 dbA.

BODY STRUCTURE

If composite, aluminum, or other materials other than steel are proposed for body panels, bidder must provide justification for this choice and provide details of body construction.

Construction to meet or exceed FMVSS crash and rollover specifications. Construction must meet or exceed FMVSS and the National School Transportation Specifications & Procedures.

Steel body parts to be thoroughly rust proofed after fabrication.

For steel body panels: baked on polyurethane paint. Aluminized interior panels below side windows. 16-gauge steel side-walls.

Chip guard & door edge cowl skirt protection.

BUMPERS

Front and rear: blue (heavy duty)

COWLING MATERIAL

Fiberglass or equal. (May not be needed on all manufacturer. Bid according to manufacturer recommendation)

CRASH PADS/BARRIERS

Per FMVSS

Pro-foam II Gray Barriers

DOORS, EMERGENCY AND EXIT

Latch buzzer rear.

Center mounted inside and outside handles.

Upper and lower panels of approved safety glass.

Number and design of all emergency exits must meet FMVSS No. 217.

Exterior access handles on all emergency doors must include a 6" directional arrow showing direction of movement to release/open the door.

Vandal lock and wired to prevent vehicle motion when locked.

See ROOF ESCAPE HATCH for additional emergency exit information.

DOOR, SERVICE

All doors shall be equipped with padding at the top edge of each door opening. Padding shall be at least three inches wide and one inch thick and extend the full width of the door opening. All door hinges must be equipped with grease fittings or lubrication ports.

Air operated with regulatory limiting valve.

Two leaf, outward opening, with windows top and bottom.

Entrance door equipped with security lock and entrance door windows to be thermo-pane standard. Red/Amber/Door opening switches mounted on left side of driver.

ENTRANCE

4-Step stainless steel step well (3-steps & the 4th step is actually the floor inside of bus). Riser should be calculated by the mfg. consistent w/the related FMVSS, frame rail height and tire size.

FLOORS

Heavy Duty rubber covering, 16" ribbed tread on entrance steps, and 13" on aisles. Rear wheel houses and area under seats to be completely covered with smooth rubber mat. All seams to be bonded and smooth.

SUB-FLOOR: 5/8 inch marine or equivalent plywood. (Premium grade exterior plywood acceptable) Plywood to be screwed to sub-floor with all exposed edges sealed.

FUEL TANK ACCESS

Right side fill access, with spring loaded hinge and lock. Fuel tank sending unit access cover plate in bus floor.

HEADROOM

77 or 78" inches standard.

HEATING SYSTEM

Bidder must include a complete description of the heating system, including heating source specifications, direct Criteria Air Pollutant (NO_x and PM) emissions per unit of fuel, hourly fuel consumption at varying low ambient temperatures and emitter capacities and locations.

Heating system must maintain the bus interior temperatures as specified in SAE test procedure J2233 *without the use of supplemental electric resistance heat.*

System must include accessible bleeder valves appropriately placed in the return lines to remove air from hydronic heater lines.

Set of two (2) 6" overhead fans shall be provided to assist in both defrosting and cooling with installation not to restrict visibility.

Heat Source

Oil-fired heating system as standard (provide alternative(s) as options)

Rear exhaust. Top-rear exhaust preferred.

Emitters

All heater cores to be copper tube coil design with aluminum fins.

- Driver heater
- Stepwell heater/defroster
- Defroster with channel shall run full length of windshield
- Set of two 6" overhead fans shall be provided to assist in both defrosting and cooling w/ installation not to restrict visibility.
- Heating system must be of sufficient capability to maintain the bus interior temperatures as specified in SAE test procedure J2233.
- System must include accessible bleeder valves appropriately placed in the return lines to remove air from the heater fluid lines, if equipped.
- Must maintain comfortable interior temperatures in sub-zero weather.

INSULATION

Fire resistant and UL approved.

R factor of at least 6.25 in sidewall, roof, front and rear quarter sections including roof bows.

Insulate driver's area.

Acoustical ceiling panels full length of bus.

LETTERING

“School Bus” must be not less than 6” high, located between the warning signal lamps, front and rear. All other lettering will be placed on the left and right sides of the vehicle as specified by the Procuring Agency after award. Also, up to five (5) digit letter-number code will be placed on left and right front cowls, and rear of bus, 6” high.

LIGHTS, EXTERIOR

BACK-UP, WARNING: LED standard 7” dual clear.

WARNING: 8-light system/strobing LED with light monitoring system

LIGHTS, INTERIOR

Passenger & driver’s dome lights with separate switch for driver’s dome.

ADA Compliant walk and step well light to be wired to activate with entrance door control.

Red ICC tell-tale lights over emergency door loading areas.

MINIMUM SOUND

Vehicle shall adhere to minimum sound requirements for light vehicles as stated in FMVSS 141, unless that standard is superseded for vehicles of this weight class.

MIRRORS, INSIDE

6” x 30”; Rear View

MIRRORS, OUTSIDE

Two each left and right rear view mirrors.

All exterior mirrors heated as standard equipment.

MUD FLAPS

Front each wheel and rear each wheel.

Fender rubbers on front and rear wheel well extensions

PASSENGER CAPACITY

Bid mfg. Equivalent within the 90 passenger. May offer reduced seating option with price reduction. Reduced seating options must not exceed FMVSS maximum seat spacing and barrier requirements.

POWER PORT

12-volt DC power port in driver’s area

RADIOS

AM/FM/CD player/PA; inside/outside speaker; 6 roof-mounted speakers inside. Dash-mounted, hand-held microphone.

One AM/FM antenna on driver’s side.

Two-way radio option from dealer provided selection.

RAILS

Three exterior rails at or near bottom of window line, seat cushion line and floor line.

ROOF ESCAPE HATCH

Open-hatch warning buzzer as standard.

Minimum five (5) year warranty for installation, workmanship, materials and leaks.

One roof mounted, ventilated escape hatch; second roof escape hatch if required to meet FMVSS formula.

TRANSPEC models 1900, 1925 or Specialty model 8645, or equivalent

SAFETY EQUIPMENT

First Aid Kit per National School Transportation Specifications and Procedures Manual (NSTSP)

Body Fluid Kit

Three Safety Triangles with secure on-board storage

Belt Cutter: A Tie-Tech belt cutter shall be installed in the Safety Equipment storage box.

Fire Extinguisher: 5# min. dry type A-B-C

SEATING, DRIVER

If the bus is equipped with an air compressor, the driver's seat shall include air suspension.

The driver's seat shall be of a high-back type with a minimum seat back adjustment of fifteen (15) degrees and a head restraint accommodating sizes through ninety-five (95) percentile adult male (as defined in FMVSS 208).

The driver's seat shall have minimum distance between the steering wheel and the seat back not less than eleven inches (11") with a minimum aft adjustment of six inches (6").

The driver's seat shall provide for fore-and-aft and up and down adjustment and shall be contoured with adequate support on the sides, including but not limited to arm rests.

Driver's station should be rearward so the seat can be moved back further.

Driver's seat shall be Bostrum #2239488-A78 or National Air Model 195 with arm rests.

A Type II seat belt with adjustable lap-shoulder, ERL type w/3-point hitch.

SEATING, PASSENGER

Seat belts to be included and installed at time of manufacture. Forward facing, fully padded, 52 oz. upholstery. Not less than 13" per passenger seat width, sidewall to aisle. Minimum 12" aisle width per FMVSS.

pro-foam II

SIGNAGE

Two inches wide by eight inches high reflective letters, front and rear school bus signs. 1.25 inch reflective tape to outline rear door, school bus sign and rear windows. Two-inch reflective stripe at top of floor level rub rail on each side of bus. Procuring Agency may request additional striping as an option not to exceed state or federal safety specifications and standards.

STOP SIGNAL ARM

One, driver controlled, hinged, swing-out type to meet FMVSS 131. Double faced, alternating flashing red lamps, one each mounted top and bottom of the stop sign. Sign(s) and lights automatically activate with the entrance door control.

SUNVISORS

Transparent plexiglass 6" x 30" front

WHEEL CHOCKS

Two each with tie downs and secure on-board storage

WINDOWS

Bids must meet or exceed State of Vermont Uniform School Bus Standard and bid specifications.

All passenger windows will be 12" minimum (both top and bottom). Side passenger windows (both top and bottom) will be minimum of 12" in height each.

Thermopane windows in the following locations:

- drivers sliding window
- service door windows
- first two passenger windows right side.

Driver's window and entrance door glass tinted green, side windows tinted.

WINDSHIELD

Standard flat, tinted (curved may be substituted if manufacturer's standard for the vehicle offered)

WIPERS

Both sides, electric, intermittent 2-speed, heavy duty motors, with washers.

Arctic all weather blades.

WIRING

All wiring shall conform to the standards of the Society of Automotive Engineers. It shall be color and number coded, insulated and protected by covering of fibrous loom, or equivalent covering. All fuse/circuit breaker blocks shall have circuit identification decals.

Wiring shall be clearly differentiated by color: 12VDC, high voltage DC, and AC.

REQUEST FOR PROPOSALS

RFP #: MVRTD 07.02.2020

GENERAL REQUIREMENTS AND SPECIFICATIONS Heavy Duty Battery Electric Transit Buses

Procurement Schedule

Release Date:	July 2, 2020
Deadline to Submit Approved Equal Requests and Questions:	July 30, 2020
Procuring Agency Response To Approved Equal Requests and Questions:	August 13, 2020
Proposals Due:	August 27, 2020 (4:00pm)
Anticipated Contract Award:	September 17, 2020

VEIC
20 Winooski Falls Way, Suite 500
Winooski, VT 05404

On behalf of:
MARBLE VALLEY REGIONAL TRANSIT DISTRICT

158 Spruce Street
Rutland, VT 05701

thebus.com



TABLE OF CONTENTS

Heavy Duty Battery Electric Transit Buses

July 2, 2020

1.0 GENERAL TERMS

- 1.1 INTRODUCTION
- 1.2 PROCUREMENT SCHEDULE
- 1.3 GUIDELINES FOR SUBMITTING APPROVED EQUAL REQUESTS
- 1.4 SUBMISSION OF PROPOSALS
- 1.5 REQUIRED PROPOSAL CONTENTS
- 1.6 PRICE
- 1.7 PROPOSAL EVALUATION CRITERIA
- 1.8 SINGLE PROPOSAL RESPONSE
- 1.9 PERIOD OF PROPOSAL VALIDITY
- 1.10 CHANGE ORDER PROCEDURE
- 1.11 DELIVERY REQUIREMENTS

2.0 TECHNICAL SPECIFICATIONS

- 2.1 GENERAL DESIGN REQUIREMENTS
- 2.2 SPECIFIC DESIGN REQUIREMENTS
- 2.3 CHASSIS/POWER PLANT
- 2.4 ELECTRICAL, ELECTRONIC AND DATA COMMUNICATION SYSTEMS
- 2.5 VEHICLE CHARGING REQUIREMENTS
- 2.6 QUALITY ASSURANCE PROVISIONS
- 2.7 WARRANTY PROVISIONS
- 2.8 TRAINING, MANUALS, AND PARTS LIST
- 2.9 OPTIONS/ALTERNATES

3.0 PRICE FORM

4.0 CONTRACT PROVISIONS

- 1. GENERAL CONTRACT PROVISIONS
- 2. SPECIAL CONTRACT PROVISIONS
- 3. OTHER FEDERAL REQUIREMENTS
- 4. ATTACHMENT C: STANDARD STATE PROVISIONS

1.0 GENERAL TERMS

1.1 Introduction

This is a procurement conducted by the Marble Valley Regional Transit District of Rutland, Vermont, referred to here as the “Procuring Agency,” with support from VEIC.

The Procuring Agency provides public transportation services in Rutland County, Vermont and surrounding communities. The mission of the Procuring Agency is to improve the well-being of individuals and communities by providing and promoting outstanding bus service.

The Procuring Agency, and their respective successors, members and service area municipalities, and assignees; and any current or future entities operating transit service in their respective current or future service area shall be allowed to purchase buses off the base pricing of the successful proposer.

The Procuring Agency will elect to purchase buses pursuant to this procurement and will enter into contracts or purchase orders (sometimes referred to as the “Contract”) directly with the successful proposer (sometimes referred to as the “Vendor” or “Contractor”) on the terms and conditions contained in this Request for Proposals (RFP) with the base pricing of the Contractor proposal.

The Procuring Agency is seeking proposals for the purchase of Heavy-Duty Battery Electric Transit Buses and associated equipment, as part of an electric bus pilot program, supported by the Volkswagen Environmental Mitigation Trust and led by the Vermont Department of Environmental Conservation.

1.2 Procurement Schedule

July 2, 2020	RFP Issued
July 30, 2020	Deadline for Receipt of Approved Equal Requests and Questions in Writing to VEIC
August 13, 2020	Approved Equal and Questions Responses
August 27, 2020	Proposals Due (4:00pm)
September 17, 2020	Anticipated Contract Award

VEIC and the Procuring Agency reserve the right to revise or amend the RFP including specifications, general contract provisions, and special contract provisions up to the time set for Proposals Due. Such revisions and amendments, if any, will be announced by addenda to this RFP. If the revisions require significant changes, the date set for Proposals Due may, at VEIC and the Procuring Agency's discretion, be

postponed. The Proposals Due date will be at least five working days after the last addendum, and the addenda will include the new date, if applicable.

1.3 Guidelines for Submitting Approved Equal Requests

All questions and clarifications regarding this RFP must be made in writing, via email. Telephone questions are not permitted. All requests for approved equals must be made on the form included in **4.2 Special Contract Provisions, Attachment 18**. No other form will be accepted. Approved equal requests must be received via email by **July 30, 2020**. All correspondence regarding this RFP shall be submitted via email to:

Kate Cahalane, VEIC
kcahalane@veic.org

All addenda items will be sent via email to each vendor receiving this document.

1.4 Submission of Proposals

Electronic copies of proposals (including scanned copies of any documents requiring signature of proposer) must be received by VEIC via email to Kate Cahalane (kcahalane@veic.org) by 4:00pm on **August 27, 2020**. Proposals received after the date and time specified above shall be considered late proposals and therefore, shall not be considered for award. Proposals should be sent with the subject line: *RFP for Heavy-Duty Battery Electric Transit Buses*.

1.5 Required Proposal Contents

- A. Complete bus build detail showing compliance with all areas of Section 2 “Technical Specifications”. Proposals shall include, but are not limited to, the following: plan and elevation views, turning radius diagrams, external and internal dimension diagrams, underbody vertical clearance, seating chart layouts, description of bus structure, description of how vehicle weight is minimized, manufacturer detail for all major components, manufacturer’s information on required lubrication and coolant, outline of how corrosion resistance requirements are met, description of accessibility to routinely serviced components, operating range and performance degradation information, diagram of operator’s controls, complete system detail of the propulsion system and energy storage system, description of regenerative braking operation, detailed analysis of expected battery performance, complete description of on-board bus charging systems, description of all warranties, information about offered training, description of required special equipment and tools, etc.

- B. A list of all similar buses delivered by the Proposer in the last five (5) years. Proposal should contain the following information: model number, vehicle length, quantity, year of delivery, type of energy storage system, name and location of receiving transit property, name and phone number of contact person at receiving transit property.
- C. A list of any late delivery occurring in the last three (3) years including the number of buses and number of days late, the reasons for late delivery, and the name and phone number of the contact person at the receiving transit property.
- D. Confirmation that the proposed bus has not been involved in any structurally-related fleet defects at any transit property in the United States or Canada in the last five (5) years. Fleet defects are defined as cumulative failures in the same components in the same or similar application occurring within the warranty period for 10% of the vehicles in a single order. All failures involving the body structure, axles, and suspension are considered structurally-related failures. If the proposed bus has been involved in a structurally-related fleet defect, proposal shall include a description of the failure, the results of a detailed investigation of the failure, detailed structural analysis, and information regarding corrective actions, including repair, re-design, and finite element analysis of the complete structure.
- E. Description and mean repair time of routine maintenance activities including preventive maintenance (PM) inspections, brake relining, small component replacement, and any other frequent maintenance task.
- F. A description of Proposer's parts supply system including locations of parts warehouses, percentage of parts regularly stocked in the U.S., and average time from receipt of orders to shipment of orders.
- G. Description of bus charging equipment including layout drawings, dimensions, and weights of major components. Include bus charging connection equipment and power conditioning equipment such as transformers, disconnect switches, control electronics, and any other supporting devices.
- H. A proposed schedule of events from purchase order to delivery of buses.
- I. A copy of Altoona Test Report(s) for all buses proposed.
- J. Identification of exceptions to any section of the RFP including explanation for the exception. If no exceptions are taken, this should be stated in the proposal.

1.6 Price

The prices shall be quoted on the required form (**3.0 Price Form**) and shall include all vehicle delivery costs to any location requested within the area of the Procuring Agency.

The Procuring Agency is generally exempt from payment of federal, state, and local taxes and taxes must not be included in proposed prices. The Procuring Agency will furnish necessary exemption certificates to the Vendor prior to ordering vehicles.

1.7 Proposal Evaluation Criteria

Proposals will be evaluated on the following criteria:

- I. Price – 30%
 - a. Total price of two (2) base buses assuming 35' buses for evaluation purposes.
 - b. For price, the proposer with the lowest overall price, as defined above, will receive all points in that category. The second lowest proposer's amount for that category will be divided into the lowest proposer's amount and the product multiplied by the maximum number of points to arrive at a point total, and so on for the other proposals. VEIC and the Procuring Agency will calculate cost as indicated above based on pricing provided by proposers.

- II. Ability to meet specifications, delivery dates, and contract documents – 25%
 - a. Proposer must request approved equals for any deviation from the specifications, all contract documents (General Terms, 4.1 General Contract Provisions, 4.2 Special Contract Provisions, 4.3 Other Federal Requirements, and all attachments/addenda), and must state delivery date for initial buses in terms of number of months after receipt of order.

- III. Reputation of Buses Proposed – 25%
 - a. Performance, Longevity, Standardization, Structural Integrity and Corrosion Resistance. Ability to meet operating criteria in Procuring Agency's service area must be demonstrated.

- IV. Vendor support, service and parts availability, length and quality of warranty – 20%
 - a. Proposer must demonstrate service reputation, the ability to customize options, vendor network, and warranty detail.

The State of Vermont Department of Environmental Conservation must provide approval of the selected vendor(s).

1.8 Single Proposal Response

If only one proposal is received in response to the Request for Proposals, detailed pricing analysis may be required of the single proposer. This analysis will likely include the proposer researching sales for similar vehicles by the manufacturer, provision of information of local dealers and purchasers of such vehicles. Direct access to the bus manufacturer shall be arranged and provided to VEIC and Procuring Agency. By submitting a proposal, the proposer agrees to this potentially burdensome requirement.

1.9 Period of Proposal Validity

The proposed pricing will not change for a period of one-hundred twenty (120) days, beginning from the Proposal Due date, unless VEIC or Procuring Agency decides, at their discretion, to negotiate price.

1.10 Change Order Procedure (after award)

- a. Contractor Changes: Any proposed change in this Contract will be submitted, for approval, to VEIC and Procuring Agency.
- b. Written Change Orders: Oral change orders are not permitted. No change in this Contract shall be made unless VEIC and Procuring Agency give prior written approval therefore. The Contractor will be liable for all costs resulting from, and/or for satisfactorily correcting, any specification changes not properly ordered by written modification to the Contract and signed by the Procuring Agency.
- c. Change Order Procedure: Within 15 days after receipt of the written change order to modify the Contract, the Contractor shall submit to VEIC and Procuring Agency a detailed price and schedule proposal for the vehicle to be delivered or work to be performed. This proposal will be accepted or modified by negotiations between the Contractor and VEIC and Procuring Agency. At that time a detailed modification shall be executed in writing by the Contractor and the Procuring Agency. Disagreements that cannot be resolved within negotiations will be resolved in accordance with the Contract dispute resolution clause. Regardless of any disputes, the Contractor shall proceed with the delivery of the bus and the work ordered.

1.11 Delivery Requirements

Manufacturers shall include a proposed delivery date in their proposal (**3.0 Price Form**) for an initial order placed shortly after contract award. Delivery date shall be shown in months following receipt of purchase order. It is the preference of the Procuring Agency that buses are delivered no later than twelve (12) months following issuance of a purchase order.

After contract award, Procuring Agency and Manufacturer shall determine a mutually agreed upon schedule for delivery of the order of buses. Failure to deliver the buses within the timeframe stipulated in the mutually agreed upon schedule may result in liquidated damages being assessed by the Procuring Agency. Assessed Liquidated damages may also be applied to subsequent orders which follow the initial order, with subsequent delivery schedules agreed upon by both parties prior to execution of purchase orders. Assessed liquidated damages shall be in the amount of \$100 per calendar day of delay per bus delayed.

The Contractor's responsibilities in the provision of any required proprietary charging infrastructure shall also be considered a key component of meeting the delivery schedule. Buses shall not be considered delivered until any required proprietary charging infrastructure is delivered. If delays in the configuration of charging infrastructure are the fault of the Contractor and result in buses not being fully operational by the deadline established in the schedule, liquidated damages may be assessed by the Procuring Agency.

At the discretion of VEIC and the Procuring Agency, the Contractor will be granted an extension of time and will not be assessed with liquidated damages for any delay beyond the time periods described in these specifications for delays caused by acts of God or of the public enemy, fire, floods, epidemics, quarantine, restrictions, strikes, labor disputes, shortage of materials and freight embargoes, or other causes deemed by VEIC and the Procuring Agency to be beyond the reasonable control of the Contractor, provided Contractor notifies VEIC and the Procuring Agency in writing of the causes of delay within five (5) calendar days from the beginning of any such delay. VEIC and the Procuring Agency shall ascertain the nature of the delay and determine whether an extension of time is warranted, which determination shall be final and conclusive. The Contractor has the burden of proof that the delay was beyond its control.

2.0 TECHNICAL SPECIFICATIONS

2.1 General Design Requirements

2.1.1 SCOPE OF WORK

These Technical Specifications describe the requirements of the Marble Valley Regional Transit District (MVRTD) as described in Section I “General Terms”, herein described as the “Procuring Agency”, for the purchase and delivery of Heavy-Duty Battery Electric Transit vehicles. These technical specifications cover air conditioned Electric Battery powered buses intended for use by all types of passengers, including passengers using a mobility device. The buses will have zero emissions through the use of a propulsion system operated by batteries with stored electric energy on the vehicle. All buses will be constructed with a low floor design profile. The low floor buses will be wheelchair lift-equipped as required and have kneeling capabilities to meet all ADA accessibility requirements. The manufacturer shall certify that each coach meets all Federal and State Vehicle Safety Standards and performance specifications for crash worthiness. Each coach shall be designed and constructed to ensure a minimum service life of at least (12) years or 500,000 miles in revenue service life.

These Technical Specifications also include the provision of any required proprietary charging infrastructure. Charging infrastructure includes charging equipment (EVSE), control and data system needed to recharge vehicle traction batteries.

The Procuring Agency shall have the right to add or remove components as provided in this specification, including the optional equipment list, as well as having rights of approval pertaining to their individual orders.

2.1.1.1 Service Proven Coach

Contractor shall not make any substantive or material changes that would differentiate one bus from another bus within an individual procurement. If the Contractor identifies a change during the manufacturing process that would materially improve the design, safety and/or performance of the bus, this change must (1) be discussed with the Procuring Agency and (2) be considered as a retrofit (if possible) to any previous buses manufactured or assembled. Any such changes must be approved by the Procuring Agency in accordance with the communications requirements of the RFP.

The Procuring Agency is willing to take advantage of new technologies when practical and risks are low. Proposer shall demonstrate the benefit of using any new technology being proposed and provide assurances that the Procuring Agency will not end up with

a problematic design. Procuring Agency requires that all coaches; coach systems and component designs shall be service-proven. A service-proven design shall meet all the following criteria:

- a) Used in revenue service for at least 3 years.
- b) Used in revenue operation for at least 5,000,000 miles with at least 100,000 miles per coach.
- c) Demonstrated as reliable with appropriate quality service history that includes documentation reflecting performance in previous applications. Procuring Agency will make all appropriate determinations in regard to acceptable service history.

Notwithstanding the above, Procuring Agency recognizes that electric buses are a new and evolving technology. Procuring Agency will accept proposals for buses with propulsion, energy storage system, and battery management system designs that do not meet the above requirements so long as Proposer demonstrates strong reliability, quality control and rigorous testing of new technology, and a timeline for when these systems are expected to meet the service-proven benchmarks.

Proposals shall highlight any proposed system or component that is not service-proven and include the above documentation. Preference will be given to proposed buses with the fewest systems or components that fail to meet the service-proven criteria.

2.1.1.2 Service Proven Coach Structure

To demonstrate that the coach structure will survive in the Procuring Agency's operating environment, the Proposer shall submit a test report from a reputable laboratory, describing a shaker table fatigue test of the Proposer's bus structure, verifying the 12-year life, and strength and fatigue life requirements. In the absence of the Shaker Table Test, the Proposer shall prepare a Structural Analysis Report (SAR) for the bus body structure. The SAR will demonstrate that the structure has sufficient strength to meet the 12-year life requirement.

2.1.1.3 Fire Safety

The bus shall be designed and manufactured in accordance with all applicable fire safety and smoke emissions regulations. These provisions shall include the use of fire-retardant/low-smoke materials, fire detection systems, firewalls, and facilitation of passenger evacuation.

All materials used in the construction of the passenger compartment of the bus are in accordance with the Recommended Fire Safety Practices defined in FMVSS 302.

Contractor, upon request, shall provide for review the smoke and flammability characteristics certification for all material used in the construction of the passenger compartment.

2.1.1.4 Approved Equals

In some instances, components and equipment are specified by brand name to ensure compatibility with member agencies' current vehicle fleets. Proposers may submit requests for approved equals for any brand name listed in this specification, regardless of whether it is accompanied by an expressed "or approved equal" statement. Requests for approved equal should be submitted in accordance with the requirements in **Section 20 of 4.2 Special Contract Provisions**, using the form provided in **Attachment 18**.

2.1.2 DEFINITIONS

The following are definitions of special terms used in the specifications:

Alternative: An alternative specification to the standard configuration coach may be considered by the Procuring Agency provided all details are submitted for approval.

Ambient Temperature: The temperature of the surrounding air. For testing purposes, ambient temperature must be between + 16° C (+50° F) and +38° C (+100° F).

Analog Signals: A continuously-variable signal that is solely dependent upon magnitude to express information content. Note: Analog signals are used to represent the state of variable devices such as rheostats, potentiometers, temperature probes, etc.

Audible Discrete Frequency: An audible discrete frequency is determined to exist if the sound power level in any 1/3-octave band exceeds the average of the sound power levels of the two adjacent 1/3-octave bands by 4 decibels (db) or more.

Baseline Configuration Bus: The bus described by the technical specifications. Signing, colors, and the destination sign reading list will be supplied by the Procuring Agency.

Battery Compartments: Designated area for placement of high- or low-voltage energy storage i.e., 12/24 VDC batteries. Battery Compartments shall be separately

designated as High Voltage Compartments, Low Voltage Compartment and Back-up Battery Compartment.

Battery Management System (BMS): Monitors energy, as well as temperature, cell or module voltages, and total pack voltage. The BMS adjusts the control strategy algorithms to maintain the batteries at uniform state of charge and optimal temperatures.

Capacity (electrical energy storage device): Two levels of capacity shall be defined, gross and useable. Gross Capacity shall be the capacity energy (kWh) of the entire battery pack and shall include usable, unusable, and/or reserve capacity energy. Useable Capacity shall be the battery kWh energy available for normal operation that is required for the bus to meet its' design operating range under normal battery management system operation.

Cells: Individual components (i.e., battery or capacitor cells).

Classes of Failures: Classes of failures are described below:

- (a) Class 1 (Physical Safety): A failure that could lead directly to a passenger or driver injury and represents a severe crash situation.
- (b) Class 2 (Road Call): A failure resulting in an en route interruption of revenue service. Service is discontinued until the coach is replaced or repaired at the point of failure.
- (c) Class 3 (Coach Change): A failure that requires removal of the coach from service during its assignments. The coach is operable to a rendezvous point with a replacement coach.
- (d) Class 4 (Bad Order): A failure that does not require removal of the coach from service during its assignments but does degrade coach operation. The failure shall be reported by driver, inspector, or hostler.

Code of Federal Regulations (CFR): A legal requirement.

Conductive Charging Interface: A charging interface that creates a physical connection between the electric vehicle supply equipment and vehicle's energy storage system to recharge the vehicle.

Curb Weight: Weight of vehicle, including maximum fuel oil and coolant and all equipment required for operation, but without passengers or driver.

dBA: Decibels with reference to 0.0002 microbar as measured on the "A" scale.

DC to DC Converter: A module that converts a source of direct current from one voltage level to another.

Design Operating Profile: The operating profile or design purposes shall consist of simulated transit type service. The duty cycle consists of three phases to be repeated in sequence: a central business district (CBD) phase of 2 miles with 7 stops per mile and a top speed of 20 mph, an arterial route phase of 2 miles with 2 stops per mile and a top speed of 40 mph, and a maximum speed of **65 mph** and a commuter phase of 40 miles with 2 stops and a maximum speed of **70 mph**.

The coach shall be loaded to Seated Load Weight (SLW) and shall average approximately 18 mph while operating on this duty cycle. Operation shall continue regardless of the ambient temperature or weather conditions. The passenger doors shall be opened and closed at each stop, and the coach shall be knelt at each stop during the CBD phase. The braking profile shall be:

16 percent of the stops at 3 fpsps
50 percent of the stops at 6 fpsps
26 percent of the stops at 9 fpsps
8 percent of the stops at 12 fpsps.

These percentages of stops shall be evenly distributed over the three phases of the duty cycle. For scheduling purposes, the average deceleration rate is assumed.

Discrete Signals: A signal which can take only pre-defined values, usually of a binary 0 or 1 nature where 0 is battery ground potential and 1 is a defined battery positive potential.

Drive System: Consists of Traction Motor, Traction Motor Controller (Inverter), gearbox or drive train and drive shaft along with related mounting hardware.

Driver's Eye Range: The 95th-percentile ellipse defined in SAE Recommended Practice J941, except that the height of the ellipse shall be determined from the seat at its reference height.

Energy Storage System (ESS): A component or system of components that allows for storage and retrieval of energy which is rechargeable by the on-vehicle system (engine/regenerative braking/ generator) or an off-vehicle energy source.

This includes a traction battery, battery management system, all power conversion electronics, and thermal management of these systems.

Electric Vehicle Supply Equipment (EVSE): The conductors, including the ungrounded, grounded and equipment grounding conductors, power conversion systems, the electric vehicle connectors, attachment plugs and all other fittings, devices, power outlets or apparatuses installed specifically for the purpose of delivering energy from the premises wiring to the battery electric vehicle.

Equal: Whenever the words “equal”, “equivalent” or “approved equal” are used in connection with make or quality of material or equipment, the proposed alternative shall be functionally compatible with and of equal or better quality than the item it is proposed to replace.

Failure Rate: The frequency of failure, expressed as failures per mile. Failure rate is the mathematical reciprocal of Mean Mileage Between Failures (MMBF).

Finite Element Analysis (FEA): A structural analysis model using a recognized computer program that will be utilized to establish the structural adequacy of the coach body, chassis, frame and other structural parts.

Fireproof Materials: Materials that will not burn or melt at temperatures less than 2,000 degrees Fahrenheit (2000°F).

Fire-Resistant Materials: Materials that have a flame spread index less than 150, as measured in a radiant panel flame test per ASTM-E 162-90.

Fire Retardant Materials: Materials that have a flame-spread index less than 35, as measured in a radiant panel flame test per ASTM-E-162-90.

Free Floor Space: Floor area available to standees, excluding ingress/egress areas, area under the seats, area occupied by the feet of seated passengers, and the vestibule area.

Gross Load: One-Hundred Fifty pounds (150 lbs.) for every designed passenger seating position, for the driver, and for each 1.5 square feet of free floor space.

Gross Vehicle Weight (GVW): Curb Weight plus Gross Load.

Gross Vehicle Weight Rating (GVWR): The maximum total weight as determined by the vehicle manufacturer, at which the vehicle can be safely and reliably operated for its intended purpose.

Gross Axle Weight Rated (GAWR): The maximum total weight as determined by the axle manufacturer, at which the axle can be safely and reliably operated for its intended purpose.

Head Injury Criterion (HIC). The following equation presents the definition of Head Injury Criterion:

$$HIC = \left\{ \left[\frac{1}{t_2 - t_1} \int_{t_1}^{t_2} a(t) dt \right]^{2.5} (t_2 - t_1) \right\}_{max}$$

Where:

a = the resultant acceleration at the center of gravity of the head form expressed as a multiple of g, the acceleration of gravity.

t₁ and t₂ = any two points in time during the impact.

Human Dimensions: The dimensions used in the Technical Specifications are defined in SAE Recommended Practice J833.

Inspector: The person or firm designated by Procuring Agency as its quality assurance representative. A representative(s) of Procuring Agency assigned to inspect materials and workmanship.

Jerk Rate: Time rate of change of acceleration and deceleration, equal to the second time derivative of velocity.

Labeled: Equipment or materials to which has been attached a label, symbol, or other identifying mark of an organization, that is acceptable to the authority having jurisdiction and concerned with product evaluation, that maintains periodic inspection of production labeled equipment or materials, and by whose labeling the manufacturer indicates compliance with appropriate standards or performance in a specified manner.

Leakage: Release of contents through a defect or crack. See "Rupture."

Low Floor Bus: A bus which, between at least the front (entrance) and rear (exit) doors, has a floor sufficiently low and level so as to remove the need for steps in the aisle between the doors and in the vicinity of these doors.

Maintenance Personnel Skill Levels: The following are definitions of maintenance personnel skill levels use in the technical specification:

- (a) 5M: Specialist Mechanic or Class A Mechanic leader
- (b) 4M: Journeyman or Class A Mechanic
- (c) 3M: Service Mechanic or Class B serviceman
- (d) 2M: Mechanic Helper or coach serviceman
- (e) 1M: Cleaner, fueler, oiler, hostler, or shifter.

In these Technical Specifications, the Procuring Agency may relate the skill levels and rating of mechanics in its operation to the above definitions.

Mean Mileage Between Failures (MMBF): The mean operating mileage between independent failures.

Metallic Hose: A hose whose strength depends primarily on the strength of its metallic parts; it can have metallic liners or covers, or both.

Minimum Standard Operating State of Charge: The minimum design operating state of charge as specified by the propulsion system integrator and battery manufacturer.

Motor (Electric): A device that converts electrical energy into mechanical energy.

Motor (Traction): An electric motor used to power the driving wheels of the bus.

Operator's Eye Range: The 95th-percentile ellipse defined in SAE recommended practice J941, except that the height of the ellipse shall be determined from the seat at its reference height.

Physical Layer: The first layer of the seven-layer International Standards Organization (ISO) Open Systems Interconnect (OSI) reference model. This provides the mechanical, electrical, functional and procedural characteristics required to gain access to the drive train and is responsible for transporting binary information between computerized systems.

Power: Work or energy divided by time.

Power Density: Power divided by mass, volume or area.

Proof (used as a suffix): Apparatus is designated as “splash proof,” “dustproof,” etc., when so constructed, protected, or treated that its successful operation is not interfered with when subjected to the specified material or condition.

Propulsion System: System that provides kinetic energy to move the vehicle proportional to operator commands. Includes, as applicable, engine, drive train, traction motors, the hybrid drive system, (HDS), energy storage system (ESS), and system controllers including all wiring and converter/inverter.

Real-Time Clock (RTC): Computer clock that keeps track of the current time.

Regenerative Braking: Deceleration of the bus by switching traction motors to act as generators, which return vehicle kinetic energy to the energy storage system.

Reliability: The probability of performing a specified function without failure and within design parameters for the distance, under actual operating conditions.

Safe: The condition in which passengers, operators, or maintenance personnel are secure from threat or danger, harm, or loss arising from improper design, manufacture, assembly, malfunction, or failure of the coach or any of its components or systems.

Seated Load: One-Hundred Fifty pounds (150 lbs) for every designed passenger seating position and the driver.

Seated Load Weight (SLW): Curb Weight plus Seated Load.

Self-Extinguishing: Materials in which flame propagation is limited to 4.0 inches when tested in accordance to FMVSS 302.

Serial Data Signals: Serial data signals are a current loop based representation of ASCII or Alphanumeric data used for transferring information between devices by transmitting a sequence of individual bits in a prearranged order of significance. Note: An example is the communication that takes place between two or more electronic components with the ability to process and store information.

Special Listings: Technical Documentation regarding the Operation and Maintenance of a vehicle or the vehicle subcomponents which is not provided as part of the OEM or OEM vendor Maintenance and Parts Manuals.

Standard(s): A firm guideline from a consensus group. Standards referenced in these Technical Specifications are the latest revisions unless otherwise stated.

State of Charge (SOC): Quantity of electric energy remaining in the battery relative to the maximum rated Amp hour (Ah) capacity of the battery expressed in percent. This is a dynamic measurement used for the energy storage system. An absolute SOC is based on total battery capacity at the beginning of useful life. A relative SOC is based on total degraded capacity at the time of measurement. The actual relationship between the SOC and energy stored expressed as a percentage shall be linear.

Standee Line: A two-inch wide line across the coach aisle in line with the front curb-side modesty panel to designate the forward area which passengers may not occupy when the coach is moving.

Stress Loops: The "pig-tails" commonly used to absorb flexing in piping.

Structure: The basic body, including floor deck material and installation, load bearing external panels, structural components, axle mounting provisions, and suspension beams and attachment points.

Subcontractor: An individual, firm, partnership, corporation, or joint venture to whom the Contractor sublets any part, subsystem, component or hardware for the Contract.

Supplier (or Sub-supplier): Person(s), firm, partnership, corporation or combination thereof who builds, produces, services, or supplies materials, equipment or apparatus for installation on the vehicle. Supplier-furnished materials or services shall comply with all contract requirements.

Tamperproof: Fasteners are designated as tamperproof when they are selected so that they cannot be easily loosened by hand or with common tools such as a flat blade or cross-recessed head screwdriver or pliers. Tamperproof Fasteners shall be tamper resistant Torx type.

Tight (used as a suffix): Apparatus is designated as "watertight," "dust-tight," etc., when so constructed that the enclosing case will exclude the specified material.

Time Down: The lapsed time during which equipment is not capable of doing useful work because of maladjustment, malfunction, or maintenance-in-progress.

Usable Battery Capacity: Usable Battery capacity is measured in kWh and is the energy available for normal operations. Usable Battery Capacity is the usable

energy from the ESS as managed through the BMS, assumed to be less than the gross capacity. It is calculated based on a useful range of something above 0% SOC and something less than 100% SOC, i.e., as an example, if the range was between 10% and 90% SOC, then the usable battery capacity would be 80% of gross battery capacity.

Warrantable End of Life (WEOL): WEOL is measure of battery degradation determined as the point at which the batteries can no longer provide the energy or power required to meet the design operating profile. It is expressed as a percentage of remaining usable battery capacity as compared to usable capacity at the beginning of useful life. For purposes of this specification, WEOL shall be a measure of the useful and intended life of the energy storage device. This measure shall be a percentage of remaining usable battery capacity based on degradation from the beginning capacity, i.e. kWh and is used in the overall calculation of mileage range. WEOL shall be used as a condition for battery replacement and to potentially initiate warranty claims.

Wheelchair: A mobility aid belonging to any class of three- or four-wheeled devices, usable indoors, designed for and used by individuals with mobility impairments, whether operated manually or powered. A “common wheelchair” is such a device that does not exceed 30 in. in width and 48 in. in length measured in. above the ground, and does not weigh more than 600 lbs. when occupied.

2.1.3 ABBREVIATIONS

The following is a list of abbreviations used in these Technical Specifications:

°F	Degrees Fahrenheit
°C	Degrees Celsius
ABS	Anti-lock Braking System
ABT	Averaging, Banking, and Trading
AllnGaP	Aluminum Indium Gallium Phosphide
ATC	Automatic Traction Control
AWG	American Wire Gauge
BRT	Bus Rapid Transit
CCD	Charge-Coupled Device
cfm	Cubic Feet Per Minute
CNG	Compressed Natural Gas
DC	Direct Current
EEPROM	Electrically Erasable Programmable Read-Only Memory
EMI	Electromagnetic Interference
ESC	Electronic Stability Control

FFY	Federal Fiscal Year (October 1-September 30)
FIP	Female Iron Pipe
fpm	Feet Per Minute
FPS	Frames Per Second
fpsps	Feet Per Second Per Second
FOB	Free On Board
FRP	Fiber reinforced plastic
g	Acceleration of Gravity
g/s	'g' per second
GVWR	Gross Vehicle Weight, Rated
HP	Horsepower
HVAC	Heating Ventilation and Air Conditioning
Hz	Hertz
IBIS	Input/Output Buffer Information Specification
ITS	Intelligent Transportation System
kHz	Kilohertz
kVArh	Reactive Power
LED	Light Emitting Diode
lbs	Pounds
LPG	Liquid Propane Gas
mA	milli-ampere
MHz	Megahertz
mph	Miles Per Hour
mphps	Miles Per Hour Per Second
MMBF	Mean Mileage Between Failures
MTTR	Mean Time To Repair
NTP	Notice to Proceed
OEM	Original Equipment Manufacturer
PA	Passenger Announcements
PDA	Personal Digital Assistant
PLC	Programmable Logic Controller
psi	Pounds Per Square Inch
psig	Pounds Per Square Inch, Gauge
RF	Radio Frequency
RFI	Radio Frequency Interference
rpm	Revolutions Per Minute
scf	standard cubic feet
SLW	Seated Load Weight
UL	Underwriters' Laboratories
ULC	Underwriters' Laboratories of Canada
VMS	Vehicle Messaging System

2.1.4 ACRONYMS, STANDARDS, AND CODES

The following is a list of acronyms, standards and codes used in these Technical Specifications. All standards and codes that are specified in these Technical Specifications are the latest revisions unless otherwise noted. The latest revision in effect for each standard at the time of Notice to Proceed (NTP) shall be used in conjunction with the Technical Specifications. The Contractor shall be responsible for obtaining all applicable standards and for supplying copies to all subcontractors/sub-suppliers. If the Contractor proposes to use a substitute standard (i.e., international standard), the Contractor is required to provide proof-of-equivalency for the Procuring Agency's review and approval for each substituted standard. The following is a list of standards and codes that must be met, whether or not they are specifically referenced in these Technical Specifications:

ADA	Americans with Disabilities Act
ANSI	American National Standards Institute
APA	American Plywood Association
APTA	American Public Transit Association
ASHRAE	American Society of Heating, Refrigeration and Air Conditioning Engineers
ASCII	American Standard Code for Information Interchange
ASME	American Society of Mechanical Engineers
ASTM	American Society for Testing and Materials
ATA	Air Transport Association of America
AWG	American Wire Gauge
AWS	American Welding Society
BMCS	Bureau of Motor Carrier Safety
CFR	Code of Federal Regulations
DOT	United States Department of Transportation
EIA	Electronic Industries Association
EPA	Environmental Protection Agency
FCC	Federal Communications Commission
FMCSR	Federal Motor Carrier Safety Regulations
FMVSS	Federal Motor Vehicle Safety Standards
FTA	Federal Transit Administration (formerly UMTA), an agency within the
DOT	Department of Transportation
IEEE	Institute of Electrical and Electronics Engineers
ISO	International Standards Organization
JIC	Joint Industrial Council
MIL	Military Specification
NEC	National Electrical Code
NEMA	National Electrical Manufacturers' Association
NFPA	National Fire Protection Association

NHTSA	National Highway Traffic Safety Administration
PTI	Pennsylvania Testing Institute at Altoona, PA
SAE	Society of Automotive Engineers
SPI	Society of the Plastics Industry
UL	Underwriters Laboratories Incorporated
USDOT	United States Department of Transportation

2.1.5 LEGAL REQUIREMENTS

The coach shall meet and the Contractor shall comply with all applicable Federal, state and local regulations in effect for the motorbuses at the date of manufacture. These may include but may not be limited to FMVSS, ADA, EPA, and all applicable FMCSR and NFPA regulations in effect at the time the notice to proceed is issued. Local regulations are defined as those below the state level. These shall include, but limit to, Federal ADA as well as state and local accessibility, safety and security requirements.

The Contractor shall submit FMVSS certificates of compliance or waiver from appropriate regulatory agency before delivery of the first bus. The Contractor must comply with all provisions of CFR 49, including Buy America Pre Award and Post Delivery requirements.

Notwithstanding anything in the Contract to the contrary, it is understood and agreed to by the Contractor that the Procuring Agency provided these Technical Specifications for the sole purpose of describing in general terms the performance required from each coach, each coach's systems, and the discrete subsystems that make up the coach. The specifications provided by the Procuring Agency do not in any way constitute a design of the coach or such subsystems or discrete components. It is further understood that Procuring Agency makes no representations regarding these Technical Specifications. It shall be incumbent on the Contractor to verify the accuracy of the Technical Specifications prior to submission of proposals.

This Technical Specification is intended to leave the Contractor free to provide its own detailed design for the basic vehicle and the vehicle's ancillary equipment. The Contractor shall assume complete and overall responsibility for the design and satisfactory operation of the vehicle and the vehicle's subsystems or components parts. The Contractor's responsibility includes, but is in no way limited to, ensuring that the design and manufacture of the vehicle and the vehicle component parts are appropriate, coordinated, compatible, and that they perform correctly throughout the life of the vehicle, whether together or individually.

In the event of any conflict between the requirements of these specifications and any applicable legal requirement, the legal requirement will prevail. Technical requirements that exceed the legal requirements are not considered to conflict.

2.1.5.1 Buy America Certification

The Contractor shall, prior to award, submit data, information, and documentation that will assist Procuring Agency in certifying that the Contractor's manufacturing plan meets or exceeds the requirements of the "Buy America" requirement in accordance with 49 CFR Part 661 and 49 USC Part 5323(j), as amended by Section 3011 of the FAST Act. The Contractor shall also submit a detailed manufacturing plan. It shall include final assembly that would typically include, at a minimum, the installation and interconnection of the electric drive train, transmission, and axles, including the cooling and braking systems; and the installation and interconnection of heating and air conditioning equipment. In addition, the installation of pneumatic and electrical systems, door systems, passenger seats, passenger assists, destination signs, mobility aid ramps, and road testing, as well as final inspections, repairs, and preparation of the coach delivery.

Note that the above section is merely additional guidance on Buy America. See **Section 2 of 4.2 Special Contract Provisions** for general information on Buy America. **Attachment 3: Buy America Certificate of Compliance (of 4.2 Special Contract Provisions)** must be submitted with proposal.

2.1.6 OVERALL REQUIREMENTS

The contractor shall ensure that the application and installation of major bus subcomponents and systems are compliant with all such subcomponent vendor requirements and recommendations. Components used in the vehicle shall be of heavy duty design and proven in transit service.

2.1.6.1 Dimensions

With the exceptions of exterior mirrors, marker and signal lights, bumpers, fender skirts, washers, wipers, ad frames, cameras, object detection systems, bicycle racks, feelers, and rub rail, the bus shall have the following overall dimensions as shown in **Figure 1** at static conditions and design height:

Figure 1
Transit Bus Exterior Dimensions

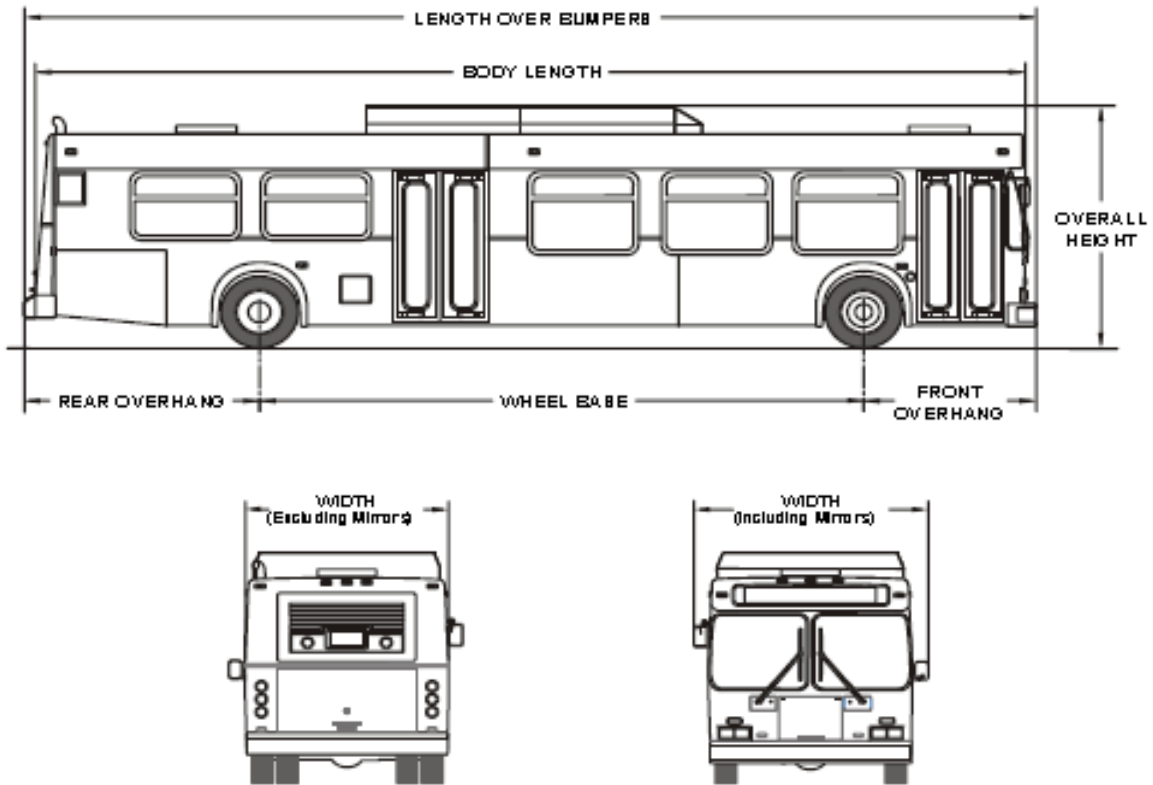

2.1.6.1.1 Bus Length

For ease of use, the following tolerances will be allowable for the given bus length. Bus length is determined as the measurement from bumper to bumper.

35-ft bus: 35-37 feet (+/- 1 in.)

2.1.6.1.2 Bus Width

The following tolerances will be allowable for the body width for the bus length:

35-ft bus: up to 102 inches

2.1.6.1.3 Bus Height

Maximum overall height shall be 141 in., including all rigid, roof-mounted items such as HVAC, current collection system, energy storage systems, etc.

2.1.6.1.4 Underbody Clearance

The bus maintains the minimum clearance dimensions as defined and shown in Figure 2 of SAE Standard J689, regardless of load up to the gross vehicle weight rating. This is accomplished with height sensors at all four corners of the vehicle.

Non-compliant clearances must be identified to Procuring Agency. Non-compliant clearances will not be considered without appropriate protection for all non-compliant structure and components.

Ramp Clearances

- a. Approach angle shall be no less than 8.5°. The approach angle is the angle measured between a line tangent to the front tire static loaded radius arc and the initial point of structural interference forward of the front tire to the ground.
- b. Departure angle shall be no less than 8°. The departure angle is the angle measured between a line tangent to the rear tire static loaded radius arc and the initial point of structural interference rearward of the rear tire to the ground.
- c. Break-over angle shall be no less than 8°. The break-over angle is the angle measured between two lines tangent to the front and rear tire static loaded radius and intersecting at a point on the underside of the vehicle that defines the largest ramp over which the vehicle can roll.

Ground Clearance

- d. Ground Clearance: Ground clearance shall be no less than 10 inches, except within the axle zone and wheel area.
- e. Axle Clearance: Axle zone clearance, which is the projected area between tires and wheels on the same axial centerline, shall be no less than 5 1/2 inches.
- f. Wheel Area Clearance: Wheel area clearance, shall be no less than 8 inches for parts fixed to the bus body and 6 inches for parts that move vertically with the axles.

2.1.6.2 Weight

It will be a design goal to construct each bus as light in weight as possible without degradation of safety, appearance, comfort, traction or performance. The curb weight for each vehicle type (length) shall not exceed 31,000 lbs.

All equipment shall be arranged so that its weight is distributed to equalize tire loading not in excess of tire rating, and maximize adhesion braking and propulsion. The tire loading on opposite sides of an axle shall be within 5% of each other. Buses at a capacity load will not exceed the tire factor limits, brake test criteria or structural design criteria.

2.1.6.3 Capacity

Proposals shall provide the following seating capacity for the following type and size vehicle:

Minimum seating capacity for 35 Foot transit Bus (with front door lift only) is 32 passengers.

The vehicle shall be designed to carry the Gross Vehicle Weight, which shall not exceed the bus Gross Vehicle Weight Rating (GVWR). The vehicle shall not exceed the individual Gross Axle Weight Rating (GAWR) at curb weight plus gross load.

2.1.6.4 Service Life and Maintenance

2.1.6.4.1 Service Life

The bus shall be designed to operate in transit service for twelve (12) years or 500,000 miles. It shall be capable of operating at least 40,000 miles per year including year twelve.

2.1.6.4.2 Maintenance and Inspection

Scheduled maintenance tasks shall be related and grouped in maximum mileage intervals in accordance with the manufacturer's recommended preventative maintenance schedule. To the extent feasible, routine scheduled maintenance actions shall not be required at intervals of less than 6,000 miles. Higher levels of scheduled maintenance tasks shall occur at even multiples of mileage for lower level tasks. Scheduled maintenance or inspection tasks as specified by the contractor shall require a skill level of 3M or less.

Diagnostic test ports, as required, will be provided for commonly checked functions on the bus, such as hydraulic, pneumatic, and cooling systems.

Each bus will be designed to facilitate the disassembly, reassembly, servicing or maintenance, using tools and equipment that are normally available as standard commercial items. Requirements for the use of unique specialized tools will be minimized. The body and structure of the bus will be designed for ease of maintenance and repair. Individual panels or sections of a monocoque composite body or other equipment that may be damaged in normal service shall be easily repairable or replaceable. Ease of repair will be related to the vulnerability of the item to damage in service.

Proposer will provide a list of all special tools and pricing required for maintaining this equipment. Said list will be submitted as a supplement to the Optional Equipment List.

2.1.6.4.3 Mean Mileage between Failures

The following are design goals for mean mileage between failures by failure class, provided that all specified preventive maintenance procedures are followed.

- Class 1: Physical Safety. Mean mileage shall be greater than 1,000,000 miles.
- Class 2: Road Call. Mean mileage shall be greater than 20,000 miles.
- Class 3: Coach Change. Mean mileage shall be greater than 16,000 miles.
- Class 4: Bad Order. Mean mileage shall be greater than 10,000 miles.

2.1.6.4.4 Mean Time to Repair

Repair time and skill levels required for various repairs to coach components shall not exceed mean time or skill levels typically required by the Procuring Agency to repair current generation transit coaches.

2.1.6.4.5 Accessibility

The bus manufacturer will give prime consideration to the routine problems of maintaining the vehicle. All bus components and systems, both mechanical and electrical, which will require periodic physical work or inspection processes are installed so that a minimum of time is consumed in gaining access to the critical repair areas. It will not be necessary to disassemble portions of the bus structure and/or equipment such as seats and flooring under seats in order to gain access to these areas.

All systems or components serviced as part of periodic maintenance or whose failure may result in Class 1 or Class 2 failures shall be readily accessible for service and inspection. Relative accessibility of components, measured in time required to gain access, shall be inversely proportional to frequency of maintenance or repair of the components.

2.1.6.5 Operating Environment

The coach shall be capable of being operated at the specified performance levels, and stored and maintained without impairment resulting from the natural or induced environmental conditions within which the Procuring Agency intends to operate the coach in revenue service.

The following climatic factors shall be used as design guidelines and shall be considered as operational requirements:

- a) Temperature and Solar Load:
Ambient air temperature:

Minimum -30°F
Maximum 120°F

Humidity:
Minimum 5%
Maximum 100%

- b) Precipitation:
Maximum rainfall rate 4 inches per hour
Maximum snowfall rate 5 inches per hour
Maximum snow accumulation 18 inches
- c) Wind:
Maximum sustained speed 40 mph
Maximum gust speed 70 mph
- d) Altitude: Up to 3,000ft above sea level.
- e) Air contamination: The vehicle shall operate as specified under air contamination levels that exist in the Procuring Agency's service area.
- f) Road contamination: The vehicle shall operate as specified under the dust, trash, and leaf accumulation conditions experienced in the Procuring Agency's service area. Salt and other chemicals are frequently applied to streets during adverse winter weather conditions.

Degradation of performance due to atmospheric conditions is minimized at temperatures below -20 °F, above 115 °F or at altitudes above 3,000 ft. Speed, gradeability and acceleration performance requirements are met at, or corrected to, 77°F, 29.31 in. Hg, dry air per SAEJ1995.

Actual localized temperatures and conditions within and under the coach body may be more severe than those listed. The Contractor shall be responsible for evaluating and advising the Procuring Agency if there are any special environmental factors to which its equipment may be sensitive, and that are not listed in this section. Performance degradation at conditions other than the test standard shall not exceed one percent for each 3°F and four percent for each 1,000 feet of altitude above the standard.

If performance degradation standards cannot be met, Proposals shall illustrate the performance degradation of the buses at the same parameters outlined above.

2.1.6.6 Vibration

The Contractor shall design components-electrical, mechanical, and other connections to operate without degradation during and after exposure to vibration as encountered in normal service. Mechanical components shall be mounted to minimize transfer of vibrations to passengers.

2.1.6.7 Ride Quality

The coach shall be free from objectionable vibration and shock. All equipment mounted in the passenger area shall be free from resonance to avoid annoying audible and visual distraction. On poor road surfaces, the ride quality shall not contain excessive instability or bottoming when the coach is driven at prudent speed.

2.1.6.8 Interchangeability

Unless otherwise agreed, all units and components procured under this Contract, whether provided by Suppliers or manufactured by the Contractor, shall be duplicates in design, manufacture, and installation to ensure interchangeability among buses in each order group in this procurement. This interchangeability extends to the individual components as well as to their locations in the buses. These components include, but are not limited to, passenger window hardware, interior trim, lamps, lamp lenses and seat assemblies. Components with non-identical functions will not be, or appear to be, interchangeable.

Any one component or unit used in the construction of these buses will be an exact duplicate in design, manufacture and assembly for each bus in each order group in this Contract. Contractor will identify and secure approval for any changes in components or unit construction provided within a Contract.

In the event that the Contractor is unable to comply with the interchangeability requirement, the Contractor will notify the Procuring Agency and obtain prior written approval, including any changes in pricing.

Procuring Agency will review proposed product changes on a case-by-case basis and has the right to require extended warranties to ensure that product changes perform at least as well as the originally supplied products.

2.1.7 MISCELLANEOUS REQUIREMENTS

2.1.7.1 Guards

Piping, pumps, wiring, control rods, and equipment located within the coach shall be adequately protected against damage or interference by, or hazard to, passengers or the operator. Inclusive of this requirement shall be fluids and other related materials.

When a shield or guard is placed around a unit requiring inspection and/or lubrication, the shield shall be so secured as to provide for easy access to the unit.

All electronic and electrical systems shall function properly without degradation from electromagnetic sources and without degrading the electromagnetic environment. All electronic and electrical systems shall not be susceptible to temporary or permanent malfunctions subject to electromagnetic sources, either transient or steady state in nature. Electromagnetic interference arising from sources such as transmitters or other equipment located either on-board or adjacent to the coach or from component parts of the coach's ignition or electrical power supply system shall not degrade the operating life expectancy of the on-board electronic equipment.

2.1.7.2 Materials

Upon request of the Procuring Agency, the Contractor shall submit samples of materials for examination, tests, and concurrence. All samples requested in this Specification to be sent to the Procuring Agency, shall be delivered F.O.B. to a destination as designated by the Procuring Agency.

All parts shall be new and in no case will used, reconditioned, obsolete or discontinued parts be used. Repairs or corrective actions to parts and components supplied under this Technical Specification shall be agreed upon in advance by the Procuring Agency. Any one part or unit used in the construction of these buses shall be an exact duplicate in manufacture, design and construction of each of the base order buses. Optional buses may incorporate product improvements and upgrades with Procuring Agency approval.

Fiber reinforced components shall not have sections that are fiber or matrix rich, or fiber or matrix poor. Plastic components shall not have resin rich, or resin poor sections.

2.1.7.3 General Conditions

All piping, pumps, tubing, cables, and wiring shall be properly bracketed. All pass through holes for piping, tubing, cables, and wires shall be free of sharp and rough edges, protected by grommets, solid sleeve P-clamps, or other means to prevent damage over the life of the coaches. To the maximum extent possible all piping, tubing, and cables located underneath the bus shall have provisions to protect the systems from road debris, salt, and sand via a protective plate or other suitable means.

All mounting of assemblies and subassemblies including the traction motor and accessories shall be mechanically isolated to minimize the transmission of vibration of the body structure.

All pipe fittings shall be of heavy-duty type and shall be designed to withstand the maximum pressure that could be generated under normal or overload conditions, within the air or fluid system of which they are a component.

All coolant and water lines routed through the interior of the bus will be done in a method that prevents leaks into the interior of the bus. Provisions shall be made to retain all fluid leaks, which have the potential of entering the passenger and driver's area of the bus.

All burrs and sharp edges shall be dressed so as to prevent injury to passengers, operators, and maintenance personnel.

All clevises shall be removable and not welded to the rods.

All painted aluminum sheets shall be thoroughly cleaned and coated on the outside with zinc-chromate protective paint, or approved equal, prior to installation on the coach. All aluminum surfaces not otherwise protected and installed in areas subject to corrosion shall be anodized.

The structure shall be assembled by bolting, riveting, welding, or adhesive bonding. All welding connections shall conform to AWS standards for quality and fitness for purpose. Welding procedures, welding materials, and qualifications of welding operators and inspectors shall be in accordance with AWS and ASTM standards. Welds shall have a finished appearance where visible. For all welded connections, the contact surfaces shall be free of scale, grease, and paint. All surfaces to which springs are attached shall be of such a pattern as to prevent excessive grooving or wear of the parts.

All joints shall be protected by application of zinc-chromate metallic compound, butyl tape sealer, or approved equal, at assembly. All bolts, nuts, washers, and exposed linkage shall be zinc- or cadmium-plated carbon steel, or stainless steel. Zinc plating shall conform to the latest revision of ASTM-B-633, Type II, SC3 or SC4. Cadmium plating shall conform to the latest revision of Federal Specification QQ-P-416b, Class 2 or 3, Type II.

All bolted connections shall be designed to a minimum strength value of SAE Grade 5 or metric equivalent nuts and bolts using a minimum design margin of 1.5 based on proof load of the bolt. Bolts and nuts shall be SAE Grade 5 or better and marked according to SAE Standards J429 and J995 or metric equivalent.

Bolt projections through nuts shall exceed 1-½ threads and shall not exceed thickness of a standard nut. Should there be a reason for excessive bolt projection, the bolts shall be double-nutted.

All sheet metal screws shall comply with ASTM and SAE recommendations relative to quality and installation. Phillips headed, self-tapping, blind rivets, and “rivet nut” type fasteners shall not be used.

Specific manufacturer's recommendations as to the adjustment and settings of components shall be provided to the Procuring Agency before delivery of the first coach. Items such as air spring heights, voltage regulator, governors, electric drive train tune-up data and any other pertinent data shall be furnished to allow time to prepare service and inspection forms for initial coach inspection.

All air, oil, and water lines and openings into equipment units shall be sealed, plugged, or adequately protected against entrance of contaminants until connected.

Mounting of major assemblies including traction batteries, traction motor(s), transmission, axles, power steering and suspension components shall be such that dismounting shall be easily carried out by conventional shop methods.

Drainage shall be provided in all body structure members. Enclosed structural cavities shall be vented to prevent condense build up. Any enclosed structural cavities of steel members shall be treated with a rust-inhibiting coating.

2.1.7.4 Lubrication

A lubrication list will be provided to Procuring Agency indicating the Contractor's standard lubricants. If any lubricants used on the coach are not compatible with the Procuring Agency's lubricants, the Contractor shall be notified of any deviation, and such lubricants shall require the concurrence of the Procuring Agency prior to fabrication of the first bus.

All lubrication fittings shall be masked in order to keep them free from paint and undercoating. All lubricant sumps shall be fitted with magnetic-type, drain plugs of a standard inch-size. Fittings shall be located to be conveniently reached from a pit and/or hoist. All grease fittings shall be of the threaded type without using special adapters.

2.1.8 BODY

2.1.8.1 Design

The bus shall have a clean, smooth, simple design, primarily derived from bus performance requirements and passenger service criteria. The exterior and body features, including grilles and louvers, shall be shaped to allow complete and easy cleaning by automatic bus washers, without snagging washer brushes. Water and dirt shall not be retained in or on any body feature to freeze or bleed out onto the bus after leaving the washer.

The body and windows shall be sealed to prevent leaking of air, dust, or water under normal operating conditions and during cleaning in automatic bus washers for the service life of the bus. Exterior panels shall be sufficiently stiff to minimize vibration, drumming or flexing while the bus is in service. When panels are lapped, the upper and forward panels shall act as a watershed. The windows, hatches, and doors shall be sealed. Accumulation on any window of the bus of spray and splash generated by the bus wheels on a wet road shall be minimized.

The lower side body of the bus shall be easily repairable by either applying common composite body repair techniques or by having lower side exterior panels that are made of impact-resistant material and easily and quickly replaceable.

2.1.8.2 Materials

Body materials shall be selected and the body fabricated to reduce maintenance, extend durability, and provide consistency of appearance throughout the service life of the bus. Detailing shall be kept simple; add-on devices and trim, where necessary, shall be minimized and integrated into the basic design.

The body material shall be treated to protect them against graffiti and vandalism.

2.1.8.3 Finish and Color

All exterior surfaces shall be smooth and free of visible wrinkles and dents. Exterior surfaces to be painted shall be properly prepared as required by the paint system supplier, prior to application of paint to assure a proper bond between the basic surface and successive coats of original paint for the service life of the bus. Drilled holes and cutouts in exterior surfaces shall be made prior to cleaning, priming and painting to prevent corrosion. The bus shall be completely painted prior to installation of exterior light, windows, mirrors and other items which are applied to the exterior of the bus.

Paint shall be applied smoothly and evenly with the finished surface free of dirt and the following imperfections:

- A. Blisters or bubbles in the topcoat film.

- B. Chips, scratches, or gouges of the surface finish.
- C. Cracks in the paint.
- D. Craters where paint failed to cover due to surface contamination.
- E. Overspray.
- F. Peeling.
- G. Runs or sags from excessive flow and failures to adhere uniformly to the surface.
- H. Chemical stains and water spots.

All exterior finished surfaces shall be impervious to diesel fuel, gasoline, and commercial cleaning agents. Finished surfaces shall resist damage by controlled applications of commonly used graffiti removing chemicals. The entire bus shall be clear coated. Paint scheme to be determined at the time of award.

Base bus paint color is red, white, and black.

2.1.8.4 Numbering and Signing

Monograms, numbers, and other special signing specified by the Procuring Agency shall be applied to the inside and outside of the bus as required. Signs shall be durable and fade, chip, and peel resistant; they may be painted signs, decals, or pressure sensitive appliqué. All decals shall be sealed with clear, waterproof sealant around the edges and on all exposed edges if required by the decal supplier. Signs shall be provided in compliance with the ADA requirements defined in 49 CFR Part 38, Subpart B.

The exact wording, size, color, and locations for these signs will be provided by Procuring Agency prior to order of first vehicle.

2.1.8.5 Pedestrian Safety

Exterior protrusions along the side and front of the bus greater than ½ in. and within 80 in. of the ground shall have a radius no less than the amount of the protrusion. The exterior rearview mirrors, cameras and required lights and reflectors shall be exempt from the protrusion requirement. When used, advertising frames shall not protrude more than ⅞ in. from the body surface. Grilles, doors, bumpers and other features on the sides and rear of the bus shall be designed to minimize toeholds or handholds.

Exterior protrusions shall not cause a line-of-sight blockage for the driver.

2.1.9 STRUCTURE

2.1.9.1 Altoona Testing

The structure shall be designed to withstand the transit service conditions typical of an urban duty cycle throughout its service life. The structure of the bus shall have undergone appropriate structural testing and /or analysis to ensure adequacy of design for the urban transit service. At a minimum, appropriate structural testing and analysis shall include Altoona testing and/or Finite Element Analysis (FEA). Any items that required repeated repairs or replacement will undergo corrective action with supporting test and analysis. A report clearly describing and explaining the failures and corrective actions taken to ensure that any and all such failures will not occur will be submitted to the Procuring Agency.

The Altoona Test Report shall be provided to the Procuring Agency with the Proposal submittal. If not available, the report shall be provided prior to acceptance of first bus. Proposals that do not contain a completed Altoona Test Report must include, at a minimum:

- (1) An explanation of why the Altoona Test Report is not available.
- (2) A detailed schedule outlining when the bus will be submitted for testing and when the Altoona Test Report is expected be completed.
- (3) Information about the scope of testing (partial or full test) including component and/or material changes to be tested.

Preference will be given to proposals containing a completed Altoona Test Report.

2.1.9.2 Strength & Fatigue

The structure of the bus shall withstand the transit service conditions found in the Procuring Agency's service area throughout its service life and shall operate with minimal maintenance for a minimum of 12 years. Under normal conditions of transit service, the structure shall withstand fatigue damage that is sufficient to cause Class 1 and Class 2 failure. The structure shall also withstand impact and inertial loads due to normal street travel throughout the coach's service life without permanent deformation or damage. The Design Operating Profile shall be considered for this purpose.

2.1.9.3 Distortion

The coach, loaded to GVMR and under static conditions, shall not exhibit deflection or deformation that impairs the operation of steering mechanism, doors, windows, passenger escape mechanisms and service doors. Static conditions shall include the vehicle at rest with any one wheel or dual set of wheels on a 6-inch curb or a 6-inch deep hole.

2.1.9.4 Resonance and Vibration

All structure, body, and panel-bending mode frequencies, including vertical, lateral, and torsional modes, shall be sufficiently removed from all primary excitation frequencies to minimize audible, visible, or sensible resonant vibrations during normal service.

2.1.9.5 Material

The chassis frame rails shall be a minimum high-strength, low-alloy stainless steel (50,000 PSI yield) all chassis cross-members shall be fasted with Grade-8 equivalent high-strength steel fasteners understructure/chassis with stainless steel used in select places.

All welded and bolted construction with Grade-8 bolts and nuts. The main frame shall be a continuous section from the front of the vehicle to the aft of the rear axle. Frame rails shall not be notched, tapered, or cutout to provide clearance for electric drive train or step well installation, if high floor bus.

The bus body shall be constructed using only inherently corrosion resistant materials and fasteners to minimize deterioration. The structure and any applied panels shall not require corrosion preventative coating or after treatment either during construction or throughout the service life of the bus. Detailing shall be simple; add-on devices and trim, where necessary, shall be minimized and integrated into the basic design.

2.1.9.6 Corrosion

The coach shall resist corrosion from atmospheric conditions and road salts. The coach understructure and exterior shall maintain structural integrity and nearly maintain original appearance throughout its service life, provided it is maintained by the Procuring Agency in accordance with the procedures specified in the service manual. Metallic materials exposed to the elements and all joints and connections of dissimilar metals shall be corrosion resistant and shall be protected from galvanic corrosion. Representative samples shall withstand a two-week salt spray test in accordance with ASTM Procedure B-117 with no visual or structural detrimental effects to normally visible surfaces, and no significant structural degradation or weight loss over one percent (1%). For other members or components, all exposed surfaces under the finished coach shall be generously sprayed with non-flammable resin type undercoating.

All underbody material and steel shall be undercoated to protect against corrosion and provide additional sound deadening. The material shall be formulated with corrosion inhibitors. All mechanisms (moving or stationary parts) that are affected or rendered useless by an application of a sealant or insulation shall be protected, including vent canisters and drain pipes prior to under coating.

2.1.9.6.1 Rust Proofing

Vehicles shall adopt rust proofing techniques to protect the body of the vehicle.

Materials furnished shall be approved for use on U.S. Government vehicles (Ziebart, Poly-oleum, Corashield, or approved equal).

The compound used for rust-proofing shall be of the highest quality available for the purpose. Application methods, techniques and tooling shall provide expert workmanship in accordance with the highest standards of the trade.

The rust-proofing materials and workmanship shall be guaranteed for a minimum life expectancy of five (5) years from application date.

All surfaces requiring protection (i.e. metal, not fiberglass or aluminum) shall be completely covered by means of a not less than 2,000 p.s.i. spray.

Spray tools shall be inserted into closed areas through drilled access holes of ½" diameter maximum. After application, the holes shall be sealed with plastic or rubber caps. The rust-proofing material shall be forced into crevices, cracks, and seams. Drain holes shall not be blocked. Excess rust-proofing shall be removed from the exterior of the vehicle and the upholstery shall be clean.

2.1.9.7 Towing

Towing devices shall be provided on each end of the bus. Each towing device shall withstand, without permanent deformation, tension loads up to 1.2 times the curb weight of the bus, within 20 degrees of the longitudinal axis of the coach. The rear towing device(s) shall not provide a toehold for unauthorized riders.

The front towing devices shall allow attachment of a rigid tow bar and shall permit lifting and towing of the bus, at curb weight, by the towing devices and the tow bar until the front wheels are clear of the ground. Towing device shall accommodate flat bedding. The tow eyes shall permit lifting and towing of the bus for a short distance, such as in case of an emergency. The method of attaching the tow bar shall require the specific approval of the Procuring Agency. At a minimum, the method of attachment shall not require the removal or disconnection of front suspension or steering components. Each towing device shall accommodate a crane hook with a 1-inch throat. Two rear-mount Tow Eye Skids shall be installed.

2.1.9.8 Jacking

It shall be possible to safely jack up the bus, at curb weight, with a common 10-ton bottle or floor jack with or without special adapter, when a tire or dual set is completely

flat and the bus is on a level, hard surface, without crawling under any portion of the bus. Jacking from a single point shall permit raising the bus sufficiently high to remove and reinstall a wheel and tire assembly.

Jacking pads located on the axle or suspension near the wheels shall permit easy and safe jacking with the flat tire or dual set on a 6-inch high run up block not wider than a single tire. Jacking and changing any one tire shall be completed by a 2M serviceman in less than 30 minutes from the time the bus is approached. The coach shall withstand such jacking at any one or any combination of wheel locations without permanent deformation or damage.

2.1.9.9 Hoisting

The bus axles or jacking plates shall accommodate the lifting pads of a 2-post hoist system. Jacking plates, if used as hoisting pads, shall be designed to prevent the bus from falling off the hoist. Other pads or the bus structure shall support the bus on jack stands independent of the hoist.

The vehicle shall be capable of being lifting by the wheels.

2.1.9.10 Fire Protection

The passenger and motor compartment shall be separated by fire-resistant bulkheads. This bulkhead shall preclude or retard propagation of a motor compartment fire into the passenger compartment and is in accordance with the Recommended Fire Safety Practices defined in FTA Docket 90A, dated October 20, 1993. Only necessary openings are allowed in the bulkhead, and these must be fire-resistant. Climate controlled air shall not pass through the motor compartment. Wiring passing through the bulkhead must use connectors or other means to prevent or retard fire propagation through the bulkhead. No motor access panels shall be required in the bulkhead.

Wiring may pass through the bulkhead only if connectors or other means are provided to prevent or retard fire propagation through the bulkhead. Motor compartment access panels in the bulkhead shall be fabricated of fire-resistant material and secured with fire-resistant fasteners. These panels, their fasteners and the bulkhead shall be constructed and reinforced to minimize warping of the panels during a fire that will compromise the integrity of the bulkhead.

Vehicle shall be fully compliant with standards outlined in FMVSS 302.

Manufacturer shall supply and install the following items in each bus:

- (1) (1) 5 lb. ABC type fire extinguisher.
- (2) 2 wheel chocks.

- (3) 1 set of safety triangles complying with FMVSS 125.
- (4) 10 unit first aid kit.
- (5) Blood Borne Pathogen Kit

2.1.9.10.1 Fire Suppression

No fire suppression system shall be required so long as the battery management system is capable of thermally monitoring the internal temperature with redundant sensors internal to the battery packs. If the temperatures become high enough to affect performance, the Battery Management System shall be required to de-rate power until the temperature is reduced. If the temperatures were to continue rising, the control system shall be required to disable the vehicle.

An AMEREX V-25 Fire Suppression System shall be priced as an option

2.1.9.11 Crashworthiness

The bus body and roof structure shall withstand a static load equal to 150 percent of the curb weight evenly distributed on the roof with no more than a 6-inch reduction in any interior dimension. Windows shall remain in place and shall not open under such a load. These requirements must be met without the roof-mounted equipment installed.

The bus shall withstand a 25-mph impact by a 4000-pound automobile at any point, excluding doorways, along either side of the coach with no more than 3 inches of permanent structural deformation at seated passenger hip height. This impact shall not result in sharp edges or protrusions in the coach interior.

Exterior panels and their supporting structural members below 35" from ground shall withstand a static load of 2,000 pounds applied perpendicular to the bus anywhere below the rub rail by a pad no larger than 5 in². The load shall not result in deformation that prevents installation of new exterior panels to restore the original appearance of the bus.

The crashworthiness requirements may be met by either test or Finite Element Analysis (FEA). In addition to the above requirements, NFPA Standard 52 must be met.

2.2 Specific Design Requirements

2.2.1 EXTERIOR PANELS AND FINISHES

2.2.1.1 Strength & Installation

Only exterior panels that are above the rub rail may be structural components. Exterior surface panels shall not be installed or retained with visible rivets or fasteners.

2.2.1.2 Repair and Replacement

Exterior panels below the rub rail shall be divided into sections that are repairable or replaceable by a 3M mechanic in less than 30 minutes for a section up to 5 feet long (excludes painting).

Exterior side panels above the rub rail, where used, and below the lower daylight opening shall be repairable or replaceable by a 5M mechanic in less than 1 1/2 hours for a section up to 5 feet long (excludes painting).

2.2.1.3 Rain Gutters

Rain gutters shall either be provided or designed as an integral part of the bus body. The rain gutters shall prevent water flowing from the roof onto side windows and passenger doors. When the bus is decelerated, the gutters shall not drain onto the windshield, or the driver's side window, or onto the door boarding area. Cross sections of the gutters shall be no less than 0.25 square inches.

2.2.1.4 License Plate Provisions

Provisions shall be made to mount standard size U.S. license plates per SAE J686 on the front and rear of the bus. These provisions shall direct mount or recess the license plates so that they can be cleaned by automatic bus washing equipment without being caught by the brushes. License plates shall be mounted at the lower center or lower street side of the bus center and shall not allow a toehold or handhold for unauthorized riders.

Front license plate shall not be obstructed by bike rack or mounting bracket.

2.2.1.5 Advertising

Provisions shall be made to integrate advertising in to the exterior design of the bus. Advertising media, frames, or supporting structures shall not compromise passenger's visibility. Advertising provisions shall not cause pedestrian hazards or foul automatic bus washing equipment, and shall not cover or interfere with doors, air passages, vehicle fittings, or in any other manner restrict the operation or serviceability of the bus.

The contractor shall provide Yarder Manufacturing Stylemaster 5-67-ck, 18x45 o.d. ad sign frames (or approved equal). Four sign frames shall be provided, shipped loose inside the bus.

Procuring Agency shall have the option to delete Advertising signs.

2.2.1.6 Bike Rack

Provide and install a Sportworks model DL-2 Stainless Steel bike rack. Bike Rack shall be mounted on front bumper such that it does not block license plate or headlights.

Procuring Agency shall have the option to delete bike rack.

2.2.2 INTERIOR PANELS AND FINISHES

2.2.2.1 General

Materials shall be selected on the basis of maintenance, durability, appearance, safety, flammability, and tactile qualities. Trim and attachment details shall be kept simple and unobtrusive. Materials shall be strong enough to resist everyday abuse from vandalism; they shall be resistant to scratches and markings. Interior trim shall be secure to avoid resonant vibrations under normal operational conditions. The interior shall be generally pleasing, simple, modern, and free from superficial motifs. It shall have no sharp depressions or inaccessible areas and shall be easy to clean and maintain. To the extent practical, all interior surfaces more than 10 inches below the lower edge of the side windows or windshield shall be shaped so that objects placed on them fall to the floor when the coach is parked on a level surface.

Water and soap should not normally be sprayed directly on the instrument and switch panels. Handhold, lights, air vents, armrests, and other interior fittings shall appear to be integral with the coach interior. There shall be no sharp, abrasive edges and surfaces, and no unnecessary hazardous protuberances.

All plastic and synthetic materials used inside the coach shall be fire resistant, except vinyl seat coverings, which shall meet the requirements of FMVSS 302.

Colors, patterns, and materials for the interior trim are to be determined at the time of award.

Proposers must submit as a Request for Approval a description and samples of materials proposed. Only materials approved by the Procuring Agency shall be used.

2.2.2.2 Headroom

Headroom above the aisle and at the centerline of the aisle seats shall be no less than 78 inches and may taper in the rear portion of the bus to no less than 74 inches at the forward edge of the rear bench seat. At the centerline of the window seats, headroom shall be no less than 62 inches or no lower than the required top of the side window. Headroom at the back of the rear bench seat may be reduced to a minimum of 56 inches, but it shall increase to normal ceiling height at the front of the seat cushion.

2.2.2.3 Trim Panels

Interior side trim panels and driver's barrier shall be melamine or other approved composite plastic trim panel material that meet Docket 90A requirements and are graffiti resistant. Material shall permit easy removal of paint, greasy fingerprints, and ink from felt tip pens. Panels shall be easily replaceable and tamper-resistant. They shall be reinforced, as necessary, to resist vandalism and other rigors of transit coach service. Interior mullion trim, moldings, and trim strips shall be stainless steel, or anodized aluminum. Individual trim panels and parts shall be interchangeable to the extent practical. Untrimmed areas shall be painted and finished to exterior quality. Samples and color chips shall be supplied by the Contractor.

2.2.2.4 Driver Barrier

An opaque barrier or bulkhead between the operator and the street-side front wheelhouse or passenger seat shall be provided. The barrier shall minimize glare and reflections in the windshield directly in front of the barrier from interior lighting during night operation. The driver barrier shall be positioned to allow full adjustment of the driver's seat, which requires 45 inches from the heel point.

The barrier shall extend from below the level of the passenger or driver's seat cushion, whichever is lower, to above the level of the seated driver's head and shall fit to the bus side windows and wall to prevent passengers from reaching the driver or their personal effects. A sturdy coat hook shall be located in the street side rear corner of the driver's area. **Design of the driver's barrier, driver's locker, and location of the hook is subject to Procuring Agency approval.**

A sign frame of 21" x 22" dimensions shall be mounted on the Driver's barrier, facing the passenger compartment of the bus.

2.2.2.5 Modesty Panels

Sturdy divider panels constructed of durable, corrosion-resistant material complementing the interior trim shall be provided at the forward most seats in the high floor area of the bus. Design and installation of modesty panels located in front of forward-facing seats shall include a handhold or grab handle along its top edge. These dividers shall be mounted on the coach wall and shall project toward the aisle no further

than passenger knee projection in longitudinal seats or the aisle side of the transverse seats. Modesty panels shall extend no higher than the lower daylight opening of the side windows. Those panels forward of transverse seats shall extend to within 1 ¼ inches (+/- ¼") of the floor. Modesty panels installed at doorways shall be equipped with grab rails if passenger assists are not provided by other means.

Panels forward of longitudinal seats shall extend to below the level of the seat cushion. Dividers positioned at the doorway shall provide no less than 2 ¼ inches clearance between the modesty panel and a fully open, inward opening door, or the path of a deploying flip-out ramp to protect passengers from being pinched. The modesty panel and its mounting shall withstand normal kicking, pushing, and pull loads by 200 pound passengers without permanent visible deformation.

2.2.2.6 Headlining

Ceiling panels shall be made of durable, corrosion resistant, easily cleanable material. Headlining shall be supported to prevent buckling, drumming, or flexing, and shall be secured without loose edges. Headlining materials shall be treated or insulated to prevent marks due to condensation where panels are in contact with metal body members. Moldings and trim strips, as required to make the edges tamperproof, shall be stainless steel or aluminum. Headlining panels covering operational equipment that is mounted above the ceiling shall be on hinges for ease of service, but retained to prevent inadvertent opening. Samples and color chips shall be supplied by the Contractor.

2.2.2.7 Front End

The entire front end of the coach shall be sealed to prevent debris accumulation behind the dash and to prevent the driver from kicking or fouling wiring and other equipment with his feet. The front end shall be free of protrusions that are hazardous to passengers standing or walking in the front of the coach during rapid decelerations. Paneling across the front of the bus and any trim around the driver's compartment shall be formed metal or composite material. Formed metal dash panels shall be painted and finished to exterior quality. Composite dash panels shall be reinforced, as necessary, vandal resistant, and replaceable. All colored, painted, and plated parts forward of the driver's barrier shall be finished with a dull dark gray or black matte surface to reduce glare. Colors shall match or coordinate with the balance of the coach interior. Color chips shall be supplied by the Contractor for approval by the Procuring Agency. Any mounted equipment must have provision to support the weight of equipment.

2.2.2.8 Rear Bulkhead

The rear bulkhead and rear interior surfaces shall be composed of material suitable for exterior skin, painted and finished to exterior quality; or paneled with melamine-type

material, composite, or scratch-resistant plastic and trimmed with stainless steel, aluminum, or composite. Colors shall match or coordinate with the balance of the coach.

The rear bulkhead paneling shall be contoured to fit the ceiling, side walls, and seat backs so that any litter will tend to fall to the floor or seating surface when the bus is on a level surface. Any air vents in this area shall be louvered to reduce airflow noise and to reduce the probability of trash or litter being thrown or drawn through the grille. The panel, or sections thereof, shall be easily and quickly removable to service components located on the rear bulkhead. Grilles where access to or adjustment of equipment is required shall be heavy-duty and designed to minimize damage and limit unauthorized access.

2.2.2.9 Fastening

Interior panels shall be attached so that there are no exposed or unfinished edges or rough surfaces. Fasteners shall be corrosion resistant. Panels and fasteners shall not be easily removable by passengers. Interior trim fasteners, where required, shall be rivets or tamper-proof fasteners requiring the same tool as all other fasteners inside the bus.

2.2.3 FLOOR

2.2.3.1 Floor Design

The floor may be inclined only along the longitudinal axis of the bus, and the incline shall be less than $3\frac{1}{2}^{\circ}$ of the horizontal except locally at the doors where a 2° slope toward the door is allowed. All floor measurements shall be made with the bus at the design running height and on a level surface with the standard tires.

The floor design shall consist of two levels (bi-level construction). Aft of the rear axle extending to the rear settee riser, the floor height may be raised to a height approximately 21 in. above the lower level. An increased slope shall be allowed on the upper level not to exceed $3\frac{1}{2}^{\circ}$ off the horizontal.

2.2.3.2 Strength

The floor deck may be integral with the basic structure or securely mounted on the structure securely to prevent chafing or horizontal movement and shall be designed to last the life of the bus. Corrosion-resistant fasteners shall be used to retain the floor and all floor fasteners shall be serviceable from one side only. Tapping plates used for the floor fasteners shall be no less than the same thickness as a standard nut, and all floor fasteners shall be secured and protected from corrosion for the service life of the coach.

Any adhesives, bolts, or screws used to secure the floor to the structure shall last and remain effective throughout the life of the bus.

The floor deck shall be reinforced as needed to support passenger loads. At GVWR, the floor will have an elastic deflection of no more than 0.60 inches from the normal plane. The floor shall withstand the application of 2.5 times gross load weight without permanent detrimental deformation.

2.2.3.3 Edges

The floor shall be essentially a continuous flat plane, except at the rear steps, if applicable, and wheel housing. Where the floor meets the walls of the coach or heating ducts, the surface edges shall be blended with a circular section of radius not less than ¼ inch and a molding or cove shall prevent debris accumulation between the floor and wheel housing. If floor level heating ducts are utilized, the top of the duct shall be blended with the wall with a molding or cover to prevent debris accumulation.

2.2.3.4 Floor Protection

The floor (including flooring in the high floor area), as assembled (including the sealer, attachments, and covering), shall be waterproof, non-hygroscopic, resistant to wet and dry rot, resistant to mold growth, and impervious to insects.

Sub Floor shall be of lightweight composite material. The sub floor shall be finished and filled as necessary with a waterproof filler after installation in the manner prescribed by the manufacturer of the floor covering so that no sub floor irregularities and/or seams are visible after installation of the finish flooring. All sub-flooring seams and/or joints will be totally supported by structural framing. No transverse joints shall be used in the entrance and exit ways. To the extent possible, floor panels shall be comprised of pieces as large as possible and shall extend the full width of the vehicle. All exposed edges of the floor panels, including openings for ducts and conduits, and joints between panels shall be waterproofed and sealed prior to installation. Before applying the floor covering, all voids, fastener heads, and cracks between floor panels shall be filled with a fire-retardant, two-part epoxy, leveling compound, with the floor finished smooth and true within 1/16 inch in 3 feet in any direction. Composite flooring material shall last throughout the life of the bus.

2.2.3.5 Floor Covering

The floor covering shall be Altro Transflor or approved equal. The flooring shall have a non-skid-walking surface that remains effective in all weather conditions and complies with all ADA requirements. The floor covering, as well as transitions of flooring material to the main floor and to the stepwell area, shall be smooth and present no tripping hazards. The floor in the operator's compartment shall be easily cleaned and shall be

arranged to minimize debris accumulation. Color shall be consistent throughout the floor covering.

Bus floor shall be plainly marked with a line of contrasting color, typically matching the line on the edge of the steps, at least 2-inches wide or equipped with some other means to indicate to any person that he/she is prohibited from occupying a space forward of a perpendicular plane drawn through the rear of the driver's seat and perpendicular to the longitudinal axis of the bus. The standee line shall extend across the bus aisle.

A one-piece center strip shall extend from the vertical wall of the rear settee between the aisle sides of transverse seats to the standee line. The covering between the center strip and the wheel housing may be separate pieces. All seams and edges of the floor covering shall be sealed to prevent water from entering between the floor and covering. The floor covering shall extend up the sidewall and be held in place with aluminum strip.

Color of the floor covering will be approved by Procuring Agency at the time of award.

2.2.3.6 Driver's Platform

The operator's platform shall be of a height that, in a seated position, the driver can see an object located at an elevation of 42" above the road surface, 24" from the leading edge of the bumper. Notwithstanding this requirement, the platform height shall not position the operator such that the operator's vertical upward view is less than 15 degrees. A warning decal or sign shall be provided to alert operator to the change in floor level. The following schematic diagram illustrates a means by which the platform height can be determined, using the Critical Line of Sight. **Figure 2** illustrates the means by which this requirement was determined.

The covering of platform surfaces and risers, except where otherwise indicated, shall be the same material as specified for floor covering. Trim is provided along top edges of platforms unless integral nosing is provided.

Figure 2
Determining Platform Height

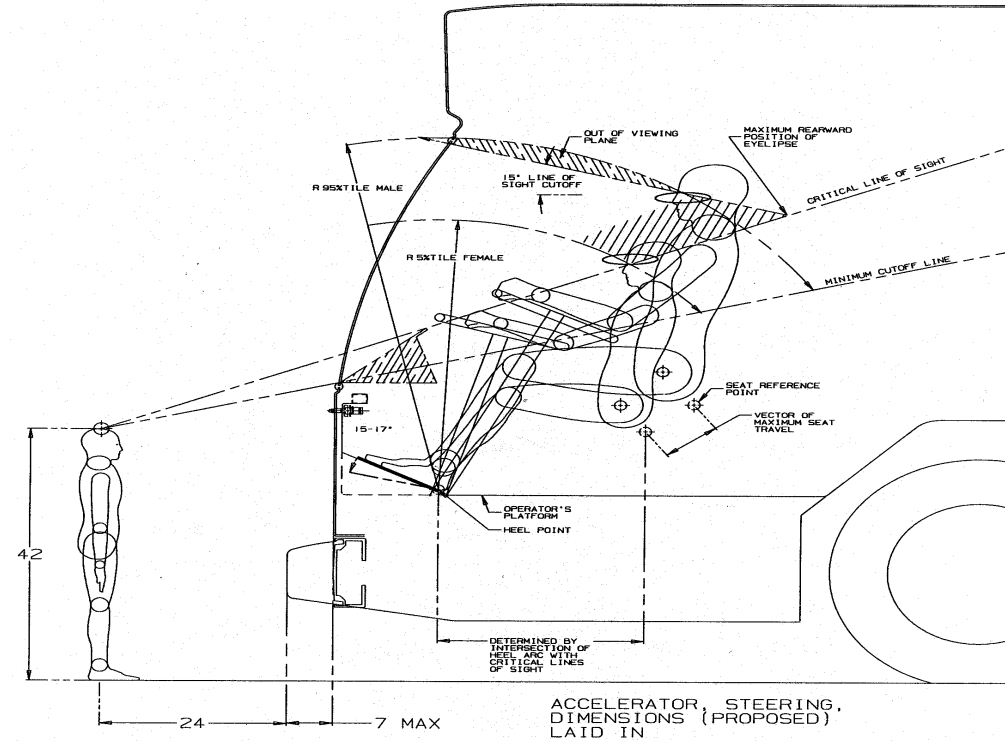

2.2.4 STEPS

2.2.4.1 Boarding Step

A maximum of one step shall be required for passenger ingress and egress from the coach. The step in each doorway shall be in a fixed location relative to the floor of the coach. At the front door, the step up from street level shall not exceed 15 1/2 inches with the coach at the design height.

2.2.4.2 Interior Step Structure

A maximum of two steps, with not more than 10-inch risers of uniform height may be provided in the aisle leading to a high-floor area in the rear of the bus. Steps shall be cut into the rear platform and be the width of the aisle as determined by the seating in the immediate area of the steps. Step structure shall be corrosion-resistant throughout the life of the coach. Each step shall simultaneously support 300-pound loads evenly distributed over any 6-inch wide section of the tread without permanent deformation and with elastic deflection of no more than 0.125 inches. Each step shall support a load of 500 pounds evenly distributed over the center half of the tread without permanent deformation. The steps shall slope only sufficient to preclude water accumulation on the

steps. All corners in the step area shall have radii no less than ¼ inches to facilitate cleaning.

All step treads shall be uniform depth, which shall be no less than 11 inches, and the plane of the step treads shall be parallel to the plane of the floor. Treads shall be covered with nonskid, heavy duty composition material that shall remain effective in all weather conditions. Color of the tread covering shall match the vestibule flooring. The edge of the high floor shall have no overhang at the step riser. The edge of the high floor and the end of the step tread shall have a bright, contrasting white band no less than two inches wide in the full width of the step. The color shall be permanently blended into the tread covering.

Front Stepwell/Threshold heater is required.

2.2.5 WHEEL HOUSING

2.2.5.1 Construction

Wheel housing shall be constructed of stainless steel material and shall be no less than 14 gauge (0.0125-inch). The wheel housing shall be securely mounted and sealed to the coach body structure and shall be isolated from dissimilar metals to prevent galvanic corrosion. Wheel housings, as installed, shall withstand impacts of a tire tread dislodging or a stone throw at 55 mph without penetration or visual deformation, which is simulated by impacts of a 2-inch steel ball with at least 200 foot-pounds of energy.

2.2.5.2 Finish

The interior of each front wheel housing shall be covered with a single FRP panel with a 25% gloss black gel coat finish. The FRP cover shall be securely mounted to the bus structure and shall withstand kicking and other abuse by boarding passengers and shall carry the structural loads of the attached passenger assists and electrical locker without visual or sensual deformation.

The rear wheel housing interior shall be covered with the same material as the bus flooring. Edges shall be trimmed with stainless steel or aluminum.

2.2.5.3 Clearance

Sufficient clearance and air circulation shall be provided around the tire, wheels, and brakes to preclude overheating when the coach is operating on the design operating profile.

2.2.5.4 Fender Skirts

Features to minimize water spray from the coach in wet conditions shall be included in wheel housing design. Any fender skirts shall be durable and easily replaceable. They shall be flexible if they extend beyond the allowable body width and shall be installed without ripples and buckles. Wheels and tires shall be removable without disturbing the fender skirts. Mud flaps shall be provided for the rear wheels and be sized effectively to protect the body and not rub on the chassis, tires or the ground.

2.2.5.5 Splash Aprons

Splash aprons, composed of ¼ inch minimum composition or rubberized fabric, shall be installed behind each wheel and shall extend downward to within 3 inches of the road surface. Apron widths shall extend across the width of the coach. Splash aprons and their attachments shall be inherently weaker than the structure to which they are attached. Splash aprons and their attachments shall not be included in the road clearance measurement. Other splash aprons shall be installed where necessary to protect coach equipment. One static strap shall be installed and properly fastened to the body.

2.2.6 PASSENGER DOORS

2.2.6.1 General

Two doors shall be provided in the right side of the bus for passenger ingress and egress. Passenger door designs shall conform to the ADA minimum clearance requirements from 49 CFR38.25(c). Doors shall be manufactured by Vapor Bus International or approved equal.

2.2.6.2 Front Door

The front door shall be forward of the front wheels and located so that the driver is able to collect or monitor the collection of fares. The front door shall be of the slide guide two-section, inward opening design.

2.2.6.3 Materials

Structure of the doors, their attachments, inside and outside trim panels, and any mechanism exposed to the elements shall be durable and constructed of inherently corrosion resistant materials (stainless steel, aluminum, or FRP). The doors, when fully opened, shall provide a firm support and shall not be damaged if used as an assist by passengers during ingress or egress.

2.2.6.4 Dimensions

FIGURE 3

Transit Bus Minimum Door Opening

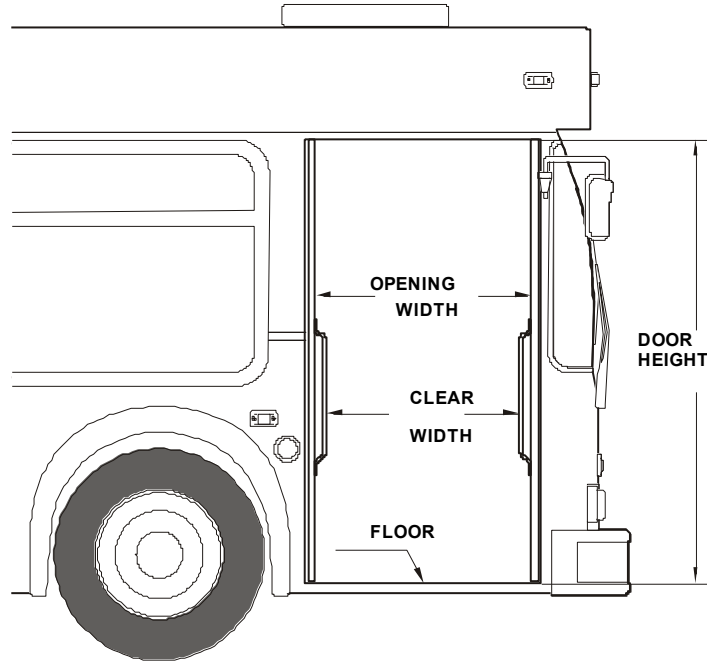

When opened, the doors shall leave an opening no less than 76 inches in height. The clear opening width, measured inside the grab rails shall be no less than 36 inches for the front door.

2.2.6.5 Door Glazing

The upper section (half of the door height) of doors shall be glazed for no less than 45 percent of the respective door opening area of each section. The lower section of the front door shall be glazed for no less than 25 percent of the door opening area of the section. The edge of a 6-inch high curb shall be visible to the seated driver through the closed front door when the coach is more than 12 inches from the curb.

2.2.6.6 Door Projection

Exterior projection of the doors shall be minimized and shall not exceed 8 inches during the opening or closing cycles or when doors are fully opened. Projection inside the coach shall not exceed 20 inches. The closing edge of each door panel shall have no less than 2 inches of soft weather stripping. The doors, when closed, shall be effectively sealed and the hard surfaces of the doors shall be at least 4 inches apart.

2.2.6.7 Door Height above Pavement

It shall be possible to open and close either passenger door when the bus is loaded to GVWR, is not kneeled, and is parked with the tires touching an 8-inch high curb on a street sloping toward the curb so that the street side wheels are 5 inches higher than the curb side wheels.

2.2.7 SERVICE COMPARTMENT AND ACCESS DOORS

2.2.7.1 Interior Access Doors

Access for maintenance and replacement of equipment shall be provided by panels and doors that appear to be an integral part of the interior. Removal of fixtures or equipment unrelated to the repair task to gain access shall be minimized. Access doors shall be hinged with props, if required, to hold the doors out of the mechanic's way. Retention of all interior access panels, except on the door actuator compartments, shall be with cross recessed head screws or tamper proof screws. Panel fasteners shall be standardized so that only one tool is required to service all special fasteners within the coach. Access doors for the door actuator compartments shall be secured with hand screws, latches, or cross recessed head screws, and shall prevent entry of mechanism lubricant into the coach interior. All fasteners that retain access panels shall be captive in the cover.

Any specified access openings in the floor shall be sealed to prevent entry of fumes, dirt and water into the bus interior. Flooring material shall be flush with the floor and shall be edge bound with stainless steel to prevent the edges from coming loose. Access openings shall be asymmetrical so that the ribs of reinstalled flooring shall be properly aligned. Fasteners shall tighten flush with the floor. Contractor shall provide a removable access section in the rear floor for maintenance access of rear suspension components.

Emergency equipment shall be provided with each bus, which shall include triangle flares. The equipment shall be mounted out of the way but still be readily accessible. Access for maintenance and replacement shall be provided by panels and doors and shall be an integral part of the interior. Access doors shall be hinged with positively retained props, as necessary, to hold the doors out of the mechanic's way. All fasteners that retain access panels shall be captive in the cover.

2.2.7.2 Exterior Access Doors

Conventional or pantograph hinged doors shall be used for all equipment requiring access from outside of the bus body. Access panels shall include, but not be limited to:

- (1) Propulsion System Component Access

- (2) Low Voltage Battery Compartment
- (3) Electrical Panel
- (4) HVAC
- (5) Energy Storage System (ESS)
- (6) Drive Shaft Access
- (7) Propulsion System Component Cooling
- (8) Drive Train Fluid
- (9) Power Steering Fluid
- (10) Windshield Washer Reservoir

Access openings shall be sized for easy performance of tasks within the compartment, including tool operating space. Access doors shall be of rugged construction, shall maintain mechanical integrity, and function under normal operations throughout the service life of the coach. Doors shall close flush with the body surface. All doors shall be hinged at the top or on the forward edge and shall be prevented from coming loose or opening during transit service or in coach washing operations. Doors with top hinges shall have safety props stored behind the door or on the door frame. All access doors shall be retained in the open position by props or counterbalancing with over-center gas-filled springs. The retaining props or springs shall be safety-latched to prevent accidental door closure in the event of a prop or spring failure. Springs and hinges shall be corrosion resistant and shall last for the service life of the coach.

Latch handles shall be flush with, or recessed behind, the body contour and shall be sized to provide adequate grip for opening. Large access doors shall be hinged up and out of the way or folded flat against the coach body and shall be easily opened by one person. These doors, when opened, shall not restrict access for servicing other components or systems. Side doors shall be equipped with plastic latches. The latches shall be standardized and shall be operable without the use of a key or tool.

Access doors larger than 100 sq. in. shall be equipped with corrosion-resistant flush-mounted latches or locks. All such access doors that require a tool to open are standardized throughout the vehicle and will require a nominal 5/16 in. square male tool to open or lock.

Service compartments for tanks or reservoirs shall not require the removal of the tank for refilling/refueling.

2.2.8 ROOF

2.2.8.1 Structure

All parts of the roof structure and skin, roof-mounted equipment, equipment covers, roof walkway, screens, and other guards shall have sufficient strength to withstand, without permanent deformation, the loads imposed by a mechanical coach washer and/or mechanic, assuming concentrated loads of 300 pounds spaced 30 inches apart (assume size 14 work boot). The roof shall be reinforced with supports integral to the roof structure to withstand the stress imposed during normal operating and maintenance conditions. Any mechanical fasteners penetrating the roof skin shall be permanently leak proof.

2.2.8.2 Roof Openings

The roof shall be framed and reinforced around the openings for air inlets and roof ventilators. Reinforcements on the roof shall be made watertight by welding or by a suitable sealing technique.

One roof ventilator and emergency escape hatch shall be installed over rear axle. The hatch shall be captive to the coach roof and reset-able by one person from inside the coach when opened or released. When opened with the coach in motion, the hatch shall provide fresh air to the coach. The hatch shall be capable of being positioned as an air scoop with either the front or rear edge open no less than 4 inches or with all four edges raised to a height of 3 ½ inches. A decal giving operating instructions shall be affixed to the interior of the hatch, and emergency instructions for opening from the exterior shall be affixed to the outside of the hatch. The hatch shall provide a clear open area for egress with a minimum opening of 425 square inches.

2.2.8.3 Access to Roof-Mounted Equipment

A non-skid, clearly marked walkway or steps shall be incorporated on the roof to provide access to equipment by service personnel without damaging any system or bus paneling. Non-skid surface treatment shall be provided around the escape hatches.

2.2.9 OPERATING COMPONENTS

2.2.9.1 Passenger Door Controls

Operation of, and power to, the passenger doors shall be completely controlled by the driver. A two-position roller switch type door control handle shall be provided to allow operator to open/close all doors. The door control shall be located in the operator's area within the hand reach envelope described in SAE Recommended Practice J287, "Driver Hand Control Reach." The driver's door control shall provide tactile feedback to indicate commanded door position and resist inadvertent door actuation. The door control handle shall be normal to the operator's straight-ahead alignment, and shall operate in accordance with the following:

- | | |
|-----------------------|------------------|
| a) Normal to bus axis | All doors closed |
| b) One notch forward | Front door open |

Door control system, including mounting and location of door control handle, requires the review and concurrence of the Procuring Agency. Operation of the door control handle shall not require the operator to stretch or lean forward in the seat, and its operation shall be free from interference by other equipment. The setting of the control shall be easily determined by position and touch.

The front door shall be equipped with a switch or valve, to allow manual manipulation of the front door by exhausting all air from the door motors to below the floor. This control shall be installed at a convenient location to the left of the operator and shall not be easily reached by passengers.

2.2.9.2 Interlocks

To preclude movement of the coach during passenger alighting, an accelerator interlock shall disable or lock the accelerator in the closed position and a brake interlock shall engage the service brake system to stop movement of the bus when the driver's door control is moved to an open position. The interlock engagement shall bring the bus to a smooth stop and be capable of holding a fully loaded bus on a 6 percent grade, until the interlocks are released. The air pressure applied to the rear axle brakes when the interlock is applied shall be adjustable from outside the bus and shall require hand tools. These interlock functions shall be active whenever the vehicle Master Run Switch is in any run position.

All door systems employing brake and accelerator interlocks shall be supplied with supporting Failure Mode Effects Analysis (FMEA) documentation, which demonstrates that failure modes are of a failsafe type, thereby never allowing the possibility of release of interlock while an interlocked door is in an unsecured condition, unless the door master switch has been actuated to intentionally release the interlocks.

The brake interlock regulator shall be non-adjustable.

2.2.9.3 Closing Force

Closing door edge speed shall not exceed 12 in. per second, and opening door speed shall not exceed 19 in. per second. Power doors shall not slam closed under any circumstance, even if the door is obstructed during the closing cycle. If a door is obstructed during the closing cycle, the pressure exerted on the obstruction shall not increase once initial contact has been made.

2.2.9.4 Actuators and Warning Chime

Doors shall open or close completely in 1.5 to 3.0 seconds from the time of control actuation. Door actuators shall be adjustable so that the speed of door opening and closing can be independently adjusted from 1 second up to 3 seconds. Actuators and the door mechanism shall be concealed from passengers but shall be easily accessible for servicing. All elements of the door and actuator system shall operate without a Class 3 failure for 50,000 miles on the design operating profile. The door actuators shall be rebuildable. Compressed air exhausted from the door system shall be routed under the floor level.

2.2.9.5 Emergency Operation

Air pressure on the door motors may provide a secondary force holding the doors closed but shall not be the primary lock. When the locked doors are manually forced open, damage shall be limited to the bending or breaking of door linkage with no resulting damage to the doors, motors, or mechanism.

In the event of an emergency, it shall be possible to open the front doors manually from inside the coach using a force of no more than 25 pounds after actuating an unlocking device at each door. The unlocking devices shall be clearly marked as an emergency device and shall require two distinct actions for activation to occur. The door emergency unlocking devices shall be accessible from the door egress area and shall be protected by a clear breakaway plastic cover. The devices shall be encased in a hinged compartment and retained by an approved latch. A decal with operational instructions shall be provided at each emergency door unlocking device. The decal shall have red text stating "TO OPEN DOOR MANUALLY BREAK TURN HANDLE". When the rear door emergency device is actuated, the interlock system shall be activated.

2.2.9.6 Manual Operator's Vent

The coach shall be equipped with a manually-operated air vent located in the driver's area. The vent shall be opened and closed by a mechanical lever and shall not be operated by a cable mechanism.

2.2.10 WINDSHIELD WIPERS AND WASHERS

2.2.10.1 Windshield Wipers

The windshield wiper system shall conform to the applicable sections of SAE Specification J198. The coach shall be equipped with a variable-speed electric-operated windshield wiper for each half of the windshield. The wiper shall be capable of clearing the streetside and curbside windshield to ensure the operator's field of view to the outside mirrors is not obstructed. The wipers shall have high and low operating speeds and intermittent wipe settings.

No part of the windshield wiper mechanism shall be damaged by manual manipulation of the arms. At 60 mph, no more than ten percent of the wiped area shall be lost due to windshield wiper lift. Both wipers shall park along the center edge of the windshield glass. Windshield wiper motors and mechanisms shall be easily accessible for repairs or service from inside or outside the coach and shall be removable as complete units. All exterior parts shall be of rust proof metal or material and shall not deposit rust residue on exterior surfaces of the coach after continued exposure to weather, coach washing, and the environment.

2.2.10.2 Windshield Washers

The windshield washer system shall, when used with the wipers, evenly and completely wet the entire wiped area. Wiper fluid lines shall be designed so that unspent fluid is drained back into the reservoir as much as possible. Two spray nozzles shall be mounted over the windshield. Hose connections and hose routing shall be approved by Procuring Agency during the pre-production meeting. Wet-arm type system is acceptable.

The windshield washer system shall have a minimum three-gallon reservoir, located for easy refilling from outside the bus and insulated to protect from freezing as much as possible. Reservoir pumps, lines, and fittings shall be corrosion-resistant, and the reservoir itself shall be translucent for easy determination of fluid level if visible from the fill location or a fluid level indicator shall be provided. Excess fluids shall drain to the coach exterior.

2.2.11 EXTERIOR LIGHTING

2.2.11.1 General

All exterior lighting, including headlights, shall be Dialight Light Emitting Diode (LED) or approved equal and shall be a nominal 12 or 24 Vdc. Lights shall be sealed to prevent entry and accumulation of moisture or dust, and each lamp shall be replaceable in less than 5 minutes by a 2M mechanic. LED lights shall be utilized for all applications where certified LED lights are available. LED lights shall be constructed with a single piece lens with the cavity seal accomplished via a potting process. A welded lens to housing construction is not allowed. All electrical connections to the LED light shall be by wire coming directly from the light housing and terminated with a weather proof connector. No interim connector shall be allowed on the body of the light. Exterior surfaces of light lenses shall be smooth to prevent dirt accumulation and ease the washing process. Light lenses shall be designed and located to prevent damage when running the vehicle through an automatic bus washer. Lights mounted on the roof or upper sections of the

bus shall have protective shields, armored, or be flush mounted to protect the lens. LED's shall be protected from chemical and abrasion degradation.

All exterior lighting and reflectors shall comply, as applicable, with FMVSS 108.

All exterior lighting shall have lifetime warranty

2.2.11.2 Clearance Marker and I.D. Lights

All clearance marker and I.D. lights shall be flush mounted LED type with smooth lenses to prevent the collection of dirt and damage during washing.

2.2.11.3 Reverse / Back-up Lights and Alarms

The reverse lights shall be 4" round, white LEDs. Visible and audible warning shall inform following vehicles or pedestrians of reverse operation. Visible reverse operation warning shall conform to SAE Standard J593. Audible reverse operation warning shall conform to SAE Recommended Practice J994-Type C or D.

2.2.11.4 Brake Lights

Four (4) 4"-round Brake LED lights shall be mounted at the rear of bus. Two of the four brake lights shall be mounted on the rear center of the bus and the remaining two lights shall be mounted near the reverse and turn signal lights.

2.2.11.5 Turn Signals

Turn-signal lights shall be provided on the front, rear, curb and street sides of the bus in accordance with federal regulations. Each side of the bus (front, rear, curb, and street) shall contain two (2) amber turn signals.

The turn signals shall be guarded for protection, and installed rearward of the front axle and forward of the rear axle as close to the axles as possible. Side turn signal lamps shall be visible from the front and rear as well as outward.

2.2.11.6 Door Lights

Lamps at the front and rear passenger doorways shall comply with ADA requirements and shall activate only when the door opens and shall illuminate the street surface to a level of no less than 1 foot-candle for a distance of 3 feet outward from the floor edge. The LEDs shall be positioned above the lower daylight opening of the windows.

2.2.11.7 Hazard Lights

The rear turn signal lights shall also serve as hazard lamps when activated by Operator and when the propulsion system compartment door is opened. Hazard lights shall not

be obstructed or hidden when the propulsion system compartment door is open. These lights shall be activated by the 4-way flasher control switch.

2.2.11.8 Service Area Lighting

LED lights shall be provided in all service compartments to generally illuminate the area for night emergency repairs or adjustments. Adequate light shall be provided to illuminate the space of the service areas to levels needed to complete typical emergency repairs and adjustments. LEDs shall be controlled by a toggle switch located inside of the service compartment. Service lighting shall shut off when the multiplexing system enters into "sleep mode". The multiplexing system shall turn on the sleep mode timer upon the activation of a service light switch. Lights mounted on service compartment doors shall be protected from the impact shock of door opening and closing the doors.

2.2.12 INTERIOR LIGHTING, CONTROLS & INSTRUMENTS

2.2.12.1 Passenger Interior Lighting

2.2.12.1.1 Lighting Controls

All interior lighting shall be I/O Control LED or approved equal. Overhead lighting shall provide general illumination in the passenger compartment and shall be controlled by a three-position switch convenient to the driver with the following functions:

- UP – All passenger lights on
- CENTER – All passenger lights off
- DOWN – Roadside Lights on

The interior lighting system shall be extinguished when the drive train selector is in reverse.

Doorway and rear step lighting system shall be illuminated when the master switch is in the RUN and NIGHT RUN positions, except the front doorway which shall be extinguished when the front door is closed.

The operator shall be able to select either dim, off or bright for interior lighting. A separate switch from the chassis lights shall operate the passenger compartment interior lights. Interior lights shall be operative without the electric drive train running.

2.2.12.1.2 Interior Lighting

The system shall provide no less than 15 foot-candles of illumination on a 1-square-foot plane at an angle of 45° centered 33 inches above the floor and 24 inches in front of the seat back at each seating position except at the rear cross seat where the illumination may be decreased to 7 foot-candles. Floor surface in the aisle shall be illuminated to no less than 10 foot-candles. The floor surface in the vestibule shall be illuminated to no less than 4 foot-candles when the front door is open and to no less than 2 foot-candles when the front door is closed.

The two forward-most lights on the curbside of the coach shall be extinguished when the front door is closed to reduce driver windshield glare with lower light intensities permitted for the curbside front aisle facing seats.

LED light fixtures shall be located above the side windows at or near the juncture of the coach ceiling and the sidewall. Safety mechanism shall prevent fixtures from falling more than 8 inches upon occurrence of a mounting failure.

Lamp fixtures and lenses shall be fire-resistant and compliant to NFPA130 requirement for lighting fixtures and shall not drip flaming material onto seats or interior trim if burned. Advertising media located in this area shall be illuminated by direct lighting. No advertisement frames shall be illuminated from behind the media.

The fixtures shall be sealed to prevent accumulation of dust and insects but shall be easily opened on hinges for cleaning and service. The lenses shall be retained in a closed position with fasteners captive in the lens that are tamper-proof consistent with all other fasteners within the bus.

2.2.12.1.3 Seating Area Lighting

The interior lighting system shall provide a minimum 15 foot-candle illumination on a 1 sq. ft. plane at an angle of 45 degrees from horizontal, centered 33 in. above the floor and 24 in. in front of the seat back at each seat position. Allowable average light level for the rear bench seats shall be 7 foot-candles.

2.2.12.1.4 Entry and Ramp Lighting

Illumination shall be provided by LED strip lighting at both locations. The system shall provide no less than 2 foot-candles of illumination on the steps and in the entry and exit areas or on the ramp when deployed. These lights shall be shielded to protect passengers' eyes from glare. Light fixtures shall be totally enclosed, watertight, and manufactured from a non-corrosive material designed to provide ease of cleaning as well as lamp and housing removal. Light fixtures shall not be easily removable by passengers. Doorway and step lights shall be protected from damage caused by passengers kicking lenses or fixtures and shall not be a hazard to passengers.

Step lighting for the intermediate steps between lower and upper floor levels shall be a minimum of 4 foot-candles and shall illuminate in all electric drive train run positions. The step lighting shall be low-profile to minimize tripping and snagging hazards for passengers and shall be shielded as necessary to protect passengers' eyes from glare.

Sufficient farebox lighting shall be provided and automatically come on whenever the front doors are opened and the run switch is in the "night run" or "night park" position.

Exterior and interior ramp lighting shall comply with CFR Part 49, Sections 19.29 and 19.31.

2.2.12.2 Driver's Lighting

The driver's area shall have a light to provide general illumination and shall illuminate the half of the steering wheel nearest the driver to a level of 10 to 15 foot-candles. The light shall be controlled by a switch conveniently located on the driver's switch panel.

2.2.12.3 Driver Controls

All switches and controls necessary for the operation of the coach shall be conveniently located in the driver's area and shall provide for ease of operation. Switches and controls shall be essentially within the hand reach envelope described in SAE Recommended Practice J287, "Driver Hand Control Reach". Controls shall be located so that boarding passengers may not easily tamper with control settings.

Instruments, switches, and controls shall be mounted in sturdy and durable panels that are fade, scratch, and chip resistant for the life of the bus. Switch and control identifiers shall be permanent for the life of the bus. All panel-mounted instruments, switches, and controls shall be easily accessible for service or replaceable, and the wiring at these controls shall be serviceable from the vestibule, the driver's seat, or the top of the panel. Wiring shall have sufficient length and be routed to permit service without stretching or chafing the wires.

Controls for electric drive train operations shall be closely grouped within the driver's compartment. These controls include the master run switch, start switch or button. The master run switch shall be a four-position rotary moisture resistant switch, approved by the Procuring Agency, with the following functions:

OFF — All electrical systems off, except power available for the passenger interior lighting, stoplights, hazard lights, radio, silent alarm, horn, fare box, driver's light, fire detection and suppression equipment (if used), compartment lights, and electronic equipment that requires continuous energizing. Idle and not connected to EVSE for a period of 14 days, the total electric load due to devices

that require continuous energizing shall not cause the traction battery to be discharged below the level necessary to propel the vehicle for ½ mile at 5MPH. Electrical loads resulting from Procuring Agency specified devices such as the fare box, radio, etc., shall not exceed 1.5 amps with the master run switch in the OFF position.

RUN — All electrical systems and electric drive train on, except the headlights, parking lights, and marker lights.

NIGHT RUN — All electrical systems and electric drive train on.

CL LPS OR PARK — All electrical systems off, except those listed in OFF, and power to destination sign, interior lights, and marker lights.

The Procuring Agency is willing to consider alternative proposals for switch functions. The labeling and functions for the master run switch shall be reviewed in detail to ensure reliability and that the switch configuration will meet the Procuring Agency's operational needs.

The door control, kneel control, windshield wiper/washer controls, and master run switch shall be in the most convenient driver locations. They shall be identifiable by shape, touch, and markings. Markings are not required for the door control. Doors shall be operated by a single control. Turn signal controls shall be floor-mounted, foot-controlled, waterproof, heavy-duty, momentary contact switches. The hazard-warning switch shall be a toggle switch with a yellow-colored handle and a minimum of 1 7/8 inches long.

All switches and controls shall be heavy-duty, premium toggle, rotary or foot operated, and marked (where required) with easily read permanent identifiers. Procuring Agency may accept devices other than toggle switches for driver controls at their sole discretion. If such alternatives are not approved during Pre-Production design review, toggle switches will be used. Configuration of switches and controls shall be consistent with function with no superfluous, unused or dual functions. Switches, controls, and instruments shall be shock-, dust-, and water-resistant consistent with the coach washing practice. Required switches and controls are:

SWITCHES:

- Master run (four-position rotary)
- Start button or switch (waterproof, rubber cap required)
- Kneel (guarded)
- Turn signal (foot operated, no identifier required)
- Interior lighting switch (NORMAL-OFF-ON)

- Climate Control (2 – position toggle switch)
- Driver's heater and defroster fan speed
- Driver's blower
- Instrument panel lighting intensity
- Driver's area light
- Hazard warning (toggle with extended yellow colored handle)
- Horn button in steering wheel hub (no identifier required)
- Headlight dimmer (foot operated, waterproof, no identifier required)
- Regenerative Braking
- Diagnostic light panel test (if not automatic)
- Electric drive train/Transmission diagnostic code
- Electric drive train shut-down override (guarded)
- Passenger exit signal (ON-OFF)
- Emergency alarm (foot operated, silent, momentary contact, no identifier required)
- Mirror control (four-way or joy stick)
- Mobility ramp master (guarded)
- Mobility ramp deploy/store
- Fire extinguisher deploy (if applicable)
- Emergency release valve (green handle)

CONTROLS:

- Accelerator pedal (no identifier required)
- Brake pedal (no identifier required)
- Door control (no identifier required)
- Windshield wipers
- Windshield washers (may be common with wiper control)
- Driver's heater & defroster controls
- Parking/emergency brake (actuation of brake, not control, shall be indicated to the driver)
- Transmission control
- Front door dump valve (no identifier required)
- Public address system
- Destination sign
- Mobile Radio
- Driver's fresh air vent

2.2.12.3.1 Foot Pedals

Accelerator and brake pedals shall be designed for ankle motion and shall meet the requirements of SAE J1516. Foot surfaces of the pedals shall be faced with wear-resistant, nonskid, replaceable material. Pedal travel shall be limited by stops under the pedals.

The vertical angle of the accelerator and brake pedals shall be determined from a horizontal plane regardless of the slope of the cab floor. The accelerator and brake pedals shall be positioned at an angle of 40-45° at the point of initiation of contact and extend downward to an angle of 20-25° at full throttle.

The location of the brake and accelerator pedals shall be determined by the manufacturer, based on space needs, visibility, lower edge of windshield, and vertical H-point. The angle of the accelerator pedal shall be determined from a horizontal plane regardless of the slope of the cab floor.

2.2.12.4 Instrumentation

The speedometer; air pressure gauge(s); Energy Storage System (ESS) state of charge (SOC) display; active charge, regeneration, and power draw display; and certain indicator lights shall be located on the front panel immediately ahead of the steering wheel. The steering wheel spokes or rim shall not obstruct the driver's vision of the instruments when the steering wheel is in the straight-ahead position. Illumination of the instruments shall be simultaneous with the marker lamps. Glare or reflection in the windshield, side window, or front door windows from the instruments, indicators, or other controls shall be minimized. Instruments and indicators shall be easily readable in direct sunlight. Indicator lights immediately in front of the driver shall include:

- a) High beam
- b) Right turn
- c) Left turn
- d) Hazard warning (may be common with turn signal indicators).
- e) Exit door open
- f) Kneel
- g) Parking brake applied
- h) Service brakes applied (may be common with parking brake indicator)

The instrument panel shall include a speedometer indicating no less than 80 mph and calibrated in maximum increments of 5 mph. The speedometer shall be a rotating pointer type, with a dial deflection of 220° to 270° degrees and 40 mph near the top of the dial. It shall be equipped with an odometer. The speedometer shall be sized and accurate in accordance with SAE Recommended Practice J678.

The instrument panel shall also include a dash mounted gauge reading from 0 to 100% of available energy storage system state of charge; and showing the state of charge available to the operator before a recharge is necessary. An additional display shall be provided showing active charge status, regeneration, and power draw.

Dash mounted air brake reservoir pressure gauge(s) with indicators for primary and secondary air tanks shall also be provided on the instrument panel.

In addition, there must be a red LED lamp located on driver's left-hand front dash panel centered in the gauge cluster area for a "Stop Requested" indicator. Also required is a "Stop Requested" sign to be located in the front vestibule with a lens area approximately 20 inches wide and 3 inches high. Sign reading is to be red text on black background and shall not be readable until the sign is illuminated. Procuring Agency may make changes to color scheme of text and background for sign at pre-production meeting. Sign shall be positioned so that both driver and passengers are visibly notified when a stop is requested. Light shall be wired so that once the light is activated, the chime shall be deactivated until after doors are opened and closed. A dash indicator light shall be activated when stop is requested. A separate indicator light and distinct chime shall be provided for the wheelchair securement positions.

2.2.12.5 Onboard Diagnostics Indicators

Critical systems or components shall be monitored with a built-in diagnostic system. This diagnostic system shall have visual and audible indicators. The diagnostic indicator lamp panel shall be located in clear sight of the driver but need not be immediately in front of the driver. The intensity of indicator lamps shall permit easy determination of on/off status in bright sunlight but shall not cause a distraction or visibility problem at night. All indicators shall have a method of momentarily testing the operation of the lamp. Whenever possible, sensors shall be of the closed circuit type, so that failure of the circuit and/or sensor shall activate the malfunction indicator.

An audible alarm shall sound when certain malfunctions are detected by the diagnostic system. The audible alarm shall be loud enough for the driver to be aware of its operation and to be inclined to discontinue operation of the coach. The following malfunction and other indicators listed shall be supplied on all coaches:

Visible Indicator	Audible Alarm	Function
Fire	Yes	Propulsion system fire alarm
Check Engine	Yes	Any electric drive train code
Charging System Indicator (12/24V)	No	Detect charging system status
Discharge	Yes	DC/DC Converter not charging
Regenerative Braking	No	Regenerative Braking ON
Anti-skid Braking	No	Not operating
Air Conditioning	No	Air conditioning fault
Low air pressure	Yes	Air system pressure low in primary or secondary reservoirs
Hydraulic	No	Hydraulic system malfunction
HVAC Fuel	No	HVAC Fuel Low (if used)
Headlight Hi-beam	No	Headlight hi-beam action
Stop Lamp	No	Stop light action
Directional Signal–left	Click	Turn indicator
Directional Signal–right	Click	Turn indicator
Kneel	Yes	Kneeling system activated
Stop Request	Dink	Activated passenger signal
Persons with Disabilities Stop Request	Double Dink	Activated at mobility aid location
Exit Door	No	Exit door open
Door Interlock Bypass	No	Door interlock disabled
Speed Switch	No	Speed above 3mph, rear doors disabled
J1939 Communication Failure	No	Indicates communication failure occurred between the Multiplex systems Main Bus Controller and control module

Procuring Agency shall have the opportunity to revise the inclusion and location of all sensors, indicators (including icons and colors), audible alarms, instrumentation, and Operator controls during pre-production meeting.

2.2.13 INTERIOR SEATING

2.2.13.1 Passenger Seats

2.2.13.1.1 Arrangement

At all transverse seating positions, hip to knee room, measured from the front of one seat back cushion (horizontally across the highest part of the seat cushion) to the seat or panel immediately in front, shall be no less than 26.5 inches. Foot room, measured at the floor forward from a point vertically below the front of the seat cushion, shall be no less than 14 inches. Seats immediately behind the wheel housings may have less than 14 inches if the seating is designed to allow the passenger to rest their feet on an angled portion of the wheel housing, but shall have foot room of no less than nine inches. Thickness of the transverse seat backs shall be designed to allow optimum passenger knee room and coach capacity.

The aisle between the seats for a “2 plus 2” arrangement shall be no less than 24” inches wide at seated passenger hip height. Seat backs shall be shaped to increase this dimension to no less than 30 inches at standing passenger hip height.

Longitudinal seats shall be of the same general design as transverse seats and the area between the longitudinal seat backs and the attachment to the sidewall of the coach shall be designed to prevent debris accumulation.

The center three rear bench seats shall be hinged at the top of the seat back, allowing the entire assembly to lift out of the way for servicing the electric drive train compartment if access through the passenger compartment is required. The two remaining rear bench seats shall be fixed in position. Hinged seat assembly shall be equipped with locks requiring a nominal 5/16” square end tool to open and a prop rod to hold the seat assembly in an open position.

The two forward-most seating positions on both sides shall be designated as priority seating for elderly and persons with disabilities and appropriately labeled with a priority seating decal approved by the Procuring Agency. Signs designating ADA priority seating shall comply with 49 CFR Part 38.27.

Seating Configurations are to be determined by Procuring Agency after award.

2.2.13.1.2 Dimensions

Seats for the various seating arrangements shall be in accordance with SAE Standard J826 and have the dimensions as follows:

Width:	17 inches-minimum
Length:	16 to 18 inches
Back Height:	15 inches-minimum
Seat Height:	17 to 18 inches
Seat Cushion Slope:	5 to 11 degrees
Seat Back Slope	8 to 17 degrees

Hip to Knee Room: 26.5 inches-minimum

2.2.13.1.3 Structure and Design

Passenger seat frame shall be American Seating Insight Prime 989 Blue or approved equal. Seating type and material shall be selected so that bus weight is minimized. Its supporting structure shall be constructed and mounted so that space under the seat is maximized to increase wheelchair maneuvering room, and is completely free of obstructions to facilitate cleaning. The structure shall be fully cantilevered from the sidewall with sufficient strength for the intended service. The lowest part of the seat assembly that is within 12 inches of the aisle shall be at least 10 inches above the floor.

In locations at which cantilevered installation is precluded by design and/or structure, other seat mounting may be allowed.

The back side of the longitudinal seat shall be closed out to prevent debris accumulation, and the underside of the seats and the sidewall shall be configured to prevent debris accumulation. The transition from the seat underside to the coach sidewall to the floor cover radius shall be smooth. All transverse objects, including seat backs, modesty panels, and longitudinal seats, in front of forward facing seats shall not impart a compressive load in excess of 1,000 pounds onto the femur of passengers ranging in size from a 5th percentile female to a 95th percentile male during a log deceleration of the coach.

This deceleration shall peak at 0.05 to 0.015 seconds from initiation. Permanent deformation of the seat resulting from two 95th percentile males striking the seat back during this 10g deceleration shall not exceed 2 inches, measured at the aisle side of the seat frame from floor to seat frame. Seat should not deflect more than 14 inches, measured at the top of the seat back, in a controlled manner to minimize passenger injury. Structural failure of any part of the seat or sidewall shall not introduce a laceration hazard.

The seat assembly shall withstand static vertical forces of 500 pounds applied to the top of the seat cushion in each seating position with less than 1/4-inch permanent deformation in the seat or its mountings. The seat assembly shall withstand static horizontal forces of 500 pounds evenly distributed along the top of the seat back with less than 1/4-inch permanent deformation in the seat or its mountings. The seat backs at the aisle position and at the window position shall withstand repeated impacts of two 40-pound sandbags without visible deterioration. One sandbag shall strike the front 40,000 times and the other sandbag shall strike the rear 40,000 times. Each sandbag shall be suspended on a 36-inch pendulum and shall strike the seat back 10,000 times each from distances of 6,8,10, and 12 inches. Seats at both seating positions shall withstand 4,000 vertical drops of a 40-pound sandbag without visible deterioration.

The sandbag shall be dropped 1,000 times each from heights of 6,8,10, and 12 inches. Seat cushions shall withstand 100,000 randomly positioned 3 1/2 inch drops of a squirting, 150 pound, smooth surfaced, buttocks-shaped striker with only minimal wear on the seat covering and no failures to the seat structure or cushioned suspension components.

The back of each transverse seat shall incorporate a handhold no less than 7/8 inch in diameter for standees and seat access/egress. The handhold shall not be a safety hazard during rapid decelerations. The handhold shall extend above the seat back near the aisle so that standees shall have a convenient vertical assist, no less than 4 inches long that may be grasped with the full hand. The handhold shall not cause a standee using this assist to interfere with seated 50th percentile male passenger. The handhold shall also be usable by a 5th-percentile female, as well as by larger passengers, to assist with seat/egress for either transverse seating position. The rear upper portion of the seat back handhold immediately forward of the transverse seats shall be padded and/or constructed of energy absorbing materials. During 10g deceleration of the bus, the HIC number (as defined by SAE Standard J211(a) and 49 CFR 571.202(a)) shall not exceed 400 for passengers ranging in size from a 6-year old child through a 95th percentile male. The seatback handhold may be deleted from the seats that do not have another transverse seat directly behind and where vertical assist is provided. Armrest shall not be included with transverse seats.

Longitudinal seats shall be the same general design as transverse seats but without seat back handholds. Longitudinal seats may be mounted on the wheelhouses.

Seat back handholds shall withstand static horizontal and vertical forces of 250 pounds applied anywhere along their length with less than 1/4-inch permanent deformation. Seat back handholds shall withstand 25,000 impacts in each direction of a horizontal force of 125 pounds with less than 1/4-inch permanent deformation and without visible deterioration.

The contractor shall be capable of providing a test report fully documenting compliance with all the requirements defined above upon request. The test report shall contain a record of all testing activities, test diagrams, testing equipment, as well as test data related to loads, deflections, and permanent deformation of the seat assembly. The report shall include a statement of compliance with the requirements.

2.2.13.2 Driver's Seat

The driver's seat shall be a USSC 9100ALX (or approved equal) black vinyl with curbside fold-down armrest, quick change seat bottom and back cushions with removable shoulder belt, protective back shell, and mechanical lumbar. The driver's

seat shall be comfortable and adjustable so that persons ranging in size from a 95th percentile male to a 5th percentile female may operate the coach. The driver's seat cushion shall have a minimum width of 18 inches, a length of 16 to 18 inches, and rearward slope of 5°. The driver's seat back height, measured from the point of intersection of the uncompressed seat cushion with the seat back to the top of the back, shall be 20 (+/- 2) inches.

The angle formed between the seat back and the seat cushion shall be adjustable in the range of 95 to 110°. Height of the seat shall be adjustable so that the distance between the top of the uncompressed seat cushion and the floor may vary between 17 and 21 inches. The seat shall be adjustable forward and rearward for minimum travel of 6 inches. While seated, the driver shall be able to make all of these adjustments by hand without complexity, excessive effort, or being pinched. Adjustment mechanisms shall hold the adjustments and shall not be subject to inadvertent changes.

Air seat: The driver's seat shall have supplemental cushioning powered by an air cylinder or diaphragm. These devices may also provide seat height adjustments. Damping shall be provided as required. The air supply hose to the driver's seat shall have Amflo (or approved equal) cp-21 male and cp-21 female quick disconnect fitting located to the left of the seat at the floor.

2.2.13.3 Driver's Seat Belt

The belt assembly should be an auto-locking retractor (ALR). All seat belts should be stored in automatic retractors. The belts shall be mounted to the seat frame so that the driver may adjust the seat without resetting the seat belt. The seat and seat belt assemblies as installed in the bus shall withstand static horizontal forces as required in FMVSS 207 and 210.

2.2.14 WINDOWS

The windows, including frames, sashes, seals, handles, glazing, and other window hardware shall be designed to last the service life of the coach.

2.2.14.1 Driver's Windows

2.2.14.1.1 Windshield

Windshield shall be in two pieces.

The windshield shall permit a driver's field of view as referenced in SAE Recommended Practice J1050. The vertically upward view shall be a minimum of 15 degrees, measured above the horizontal and excluding any shaded band. The vertically

downward view shall permit detection of an object 3 1/2 feet high no more than 2 feet in front of the coach. The horizontal view shall be a minimum of 90° about the line of sight. Any binocular obscuration due to a center divider may be ignored when determining the 90° requirement provided that the divider does not exceed a 3° angle in the driver's field of view. Windshield pillars shall not exceed 10° of binocular obscuration.

The windshield shall be designed and installed to minimize external glare as well as reflections from inside the coach. When the coach is operated at night with the passenger interior lighting on, essentially no reflections shall be visible in the windshield immediately forward of the driver's barrier. Reflections in the remainder of the windshield shall be minimized, and no reflection of any part of the coach interior behind the driver's barrier shall be visible in the windshield.

The windshield shall be easily replaceable by removing zip locks from the windshield retaining moldings. "Bonded in place" windshields shall not be used. The glazing material shall have single density tint. The upper portion of the windshield above the driver's field of view shall have a dark, shaded band with a minimum luminous transmittance of 6% when tested in accordance to ASTM D 1003.

The windshield glazing material shall have a nominal thickness laminated safety glass conforming to the requirements of ANSI Z26.1 Test Grouping 1A and the Recommended Practices defined in SAE J673.

2.2.14.1.2 Driver's Side Window

The driver's side window shall have two vertical sections, each horizontally sliding, with suitable stops. The forward section shall be provided with an external handle. Windows shall be designed to preclude opening or closing caused by acceleration or braking of the coach, and shall not rattle when in an open position. The sash frame lower rail shall be designed to drain water, due to condensation, to the exterior coach. The driver's side window shall not be bonded in place and shall be easily replaceable. The glazing material shall be nominal 1/4-inch, laminated safety glass with single density tint.

The operator's view, perpendicular through operator's side window glazing, should extend a minimum of 33 inches (840 mm) to the rear of the Heel Point on the accelerator, and in any case must accommodate a 95th percentile male operator. The view through the glazing at the front of the assembly should begin not more than 560 mm (26 inches) above the operator's floor to ensure visibility of an under-mounted convex mirror.

2.2.14.2 Side Windows

Side windows shall be Arow Global Stormtite or approved equal full fixed framed windows with black anodized frames. Side windows shall extend from the shoulder height of a seated 5th percentile female passenger to the eye level of a standing 95th percentile male passenger. Vertical mullions between windows, including the trim, shall not exceed 13 inches in width. All side windows shall be fixed in position, except as necessary to meet the emergency escape requirements. All side windows shall be easily replaceable without disturbing adjacent windows and shall be mounted so that flexing or vibration from electric drive train operation or normal road excitation is not apparent.

2.2.14.2.1 Materials

Side window glazing material shall be ¼ inch tempered or laminated safety glass with 20 – 35 percent light transmittance. The window over the side destination sign shall have essentially clear glazing. Glazing materials shall be in accordance with the latest revision of ANSI Z26.1. Sash is to be black anodized aluminum.

The window sill, seal rubber and/or any sash, or sash frame mounting rubber must be installed so that passengers cannot remove it. The body sash construction shall be such that the sash drain will prevent the entrance or back up of water into the coach. Drains shall be incorporated at the bottom of the sash, which will drain interior condensation of the sash to the exterior of the coach. All windows shall be sealed to prevent the entrance of air and water. Materials used shall be designed to withstand varying temperature extremes, road splash and salt and other exterior elements without cracking, leaking, loosening and deteriorating.

Emergency escape windows shall be top hinged and captive, and shall not fall out on the street after being pushed open. The sash frame shall be installed to prevent the sash frame from being released unless it is intentionally pushed out in an emergency. It shall also be equipped with a positive lock device that must be manually released before the window can be pushed out.

An "Emergency Push Out" instruction plate shall be furnished and installed by the Contractor in accordance with the requirements of FMVSS 217. The instruction plate shall be a permanent metal label riveted to the wall of the coach and shall not be a decal or of "paint on metal" design.

2.2.15 INSULATION

2.2.15.1 Material

Any insulation material used between the inner and outer panels shall be fire-resistant and sealed to minimize entry of moisture and to prevent its retention in sufficient quantities to impair insulation properties. Insulation properties shall be unimpaired by vibration compacting or settling during the life of the coach. The insulation material shall be non-asbestos, non-hygroscopic, and resistant to fungus and breeding of insects. Any insulation material used inside the electric drive train compartment shall be fire-resistant and shall not absorb or retain oils or water.

2.2.15.2 Performance

2.2.15.2.1 Thermal Insulation

The combination of inner and outer panels on the sides, roof, and ends of the coach, and any material used between these panels shall provide a thermal insulation sufficient to meet the interior temperature requirements. The coach body shall be thoroughly sealed so that drafts cannot be felt by the driver or passengers during normal operations with the passenger doors closed.

Proposer shall provide a summary of insulation materials and total R-values achieved in side, top, front, and rear body panels as well as in floor.

2.2.15.2.2 Sound Insulation (Interior of Bus)

The combination of inner and outer panels and any material used between them shall provide sufficient sound insulation so that a sound source with a level of 80 dBA measured at the outside skin of the coach shall have a sound level of 65 dBA or less at any point inside the coach. These conditions shall prevail with all openings, including doors and windows, closed and with the electric drive train and accessories switched off.

The coach-generated noise level experienced by a passenger at any seat location in the coach shall not exceed 80 dBA and the driver shall not experience a noise level of more than 75 dBA under the following test conditions:

- 1) The coach shall be empty except for test personnel, not to exceed 4 persons, and the test equipment.
- 2) All openings shall be closed and all accessories shall be operating during the test.
- 3) The coach shall accelerate at full throttle from a standstill to 35 mph on level commercial asphalt or concrete pavement in an area free of large reflecting surfaces within 50 feet of the coach path.
- 4) During the test, the ambient noise level in the test area shall be at least 10 dBA lower than the coach under test. Instrumentation and other general requirements shall conform to SAE Standard J366. If the noise contains

an audible discrete frequency, a penalty of 5 dBA shall be added to the sound level measured.

2.2.15.2.3 Sound Insulation (Exterior of Bus)

Airborne noise generated by the bus and measured from either side shall not exceed 70 dBA under full power acceleration when operated at 0 to 35 mph at curb weight. The maximum noise level generated by the bus pulling away from a stop at full power shall not exceed 80 dBA. The bus-generated noise at curb idle shall not exceed 70 dBA. If the noise contained an audible discrete frequency, a penalty of 5 dBA shall be added to the sound level measured. The Contractor will comply with SAEJ366 and the exterior noise requirements defined in local laws and ordinances in the Procuring Agency's service area.

2.2.16 CLIMATE CONTROL SYSTEM

The HVAC unit may be rear-mounted or roof-mounted. In any design, the dimension requirements shall be met.

It shall be a design goal to limit the HVAC system's drain on the propulsion energy storage system by utilizing other onboard energy sources, such as regenerative braking, cooling devices, compressed air and hydraulic system heat, etc. There is a preference for oil heat, but alternative fuel sources such as LPG, may be proposed. For non-electric HVAC, bidder to provide details on heating capacity, fuel storage, expected bus range implications, direct Criteria Air Pollutant (NO_x and PM) emissions per unit of fuel, and hourly energy or fuel consumption at varying low ambient temperatures.

Manufacturers are encouraged to submit recommendations for climate control system specifications, including power and fuel source, that provide the desired level of passenger and operator comfort and maximize operating range of the bus.

2.2.16.1 HVAC Capacity and Performance

The Heating, Ventilating, and Air Conditioning (HVAC) climate control system shall be capable of controlling the temperature and humidity levels of the interior of the bus as defined in the following paragraphs.

The HVAC shall provide an integrated solution for passenger heating and cooling along with a sufficient heating and cooling capacity to be used for traction battery cooling if required. Heating system total maximum power demand from the high voltage battery

shall not exceed that of the cooling system. The maximum impact of the cabin heating system energy use on range shall not exceed that of the cabin cooling system.

With the bus running at the design operating profile with corresponding door opening cycle and carrying a number of passengers equal to 150% of the seated load, the HVAC system shall maintain the average passenger compartment temperature within a range between 65°F and 80 °F, while maintaining the relative humidity to a value of 50% or less. The system shall maintain these conditions while subjected to any outside ambient temperatures within a range of 10°F to 95°F and at any ambient relative humidity levels between 5 and 50%.

When the bus is operated in outside ambient temperatures of 95°F to 120°F, the interior temperature of the bus shall be permitted to rise 0.5° for each degree of exterior temperature in excess of 95°F.

When bus is operated in outside ambient temperatures in the range of -10°F to 10°F, the interior temperature of the bus shall not fall below 55°F while the bus is running on the design operating profile.

The air conditioning portion of the HVAC system shall be capable of reducing the passenger compartment temperature from 110°F to 90°F in less than 20 minutes after system start-up. Propulsion system component temperatures shall be within the normal operating range at the time of start-up of the cool-down test. During the cool-down period, the refrigerant pressure shall not exceed safe high-side pressures, and the condenser discharge air temperature, measured 6 in. from the surface of the coil, shall be less than 45°F above the condenser inlet air temperature.

System capacity testing, including pull-down/warm-up, stabilization, and profile shall be conducted in accordance with APTA's "Recommended Instrumentation and Performance Testing for Transit Bus Air Conditioning System." The recommended locations of temperature probes are only guidelines and may require slight modifications to address actual bus design. Care must be taken to avoid placement of sensing devices in the immediate path of an air duct outlet. In general, the locations are intended to accurately represent the interior passenger area.

2.2.16.2 Controls and Temperature Uniformity

The HVAC system (excluding the operator's heater/defroster) shall be centrally controlled with an advanced electronic/diagnostic control system with provisions for extracting/reading data. The system shall be compliant with J1939 Communication Protocol for receiving and broadcasting of data.

The operator shall have full control over the defroster and operator's heater. The operator shall be able to adjust the temperature in the operator's area through air distribution and fans.

The interior climate control system shall switch automatically to the ventilating mode if the refrigerant compressor or condenser fan fails.

Interior temperature distribution shall be uniform to the extent practicable to prevent hot and/or cold spots. After stabilization with doors closed, the temperatures between any two points in the passenger compartment in the same vertical plane, and 6 inches to 72 inches above the floor, shall not vary by more than 5°F with doors closed. The interior temperatures, measured at the same height above the floor, shall not vary more than \pm 5°F, from the front to the rear, from the average temperature determined in accordance with APTA's "Recommended Instrumentation and Performance Testing for Transit Bus Air Conditioning System". Variations of greater than \pm 5°F will be allowed for limited, localized areas provided the majority of the measured temperatures fall within the specified requirement. HVAC system shall be capable of automatically reducing the rate of introduction of outdoor air in proportion to the number of passengers present, while maintaining temperature and humidity within specified ranges.

2.2.16.3 Air Flow

2.2.16.3.1 Passenger Area

The cooling mode of the interior climate control system shall be capable of introducing air into the bus at or near the ceiling height at a minimum rate of 25 cubic feet per minute (cfm) per passenger based on the standard configuration bus carrying a number of passengers equal to 150% of the seated load. Airflow shall be evenly distributed throughout the bus with air velocity not exceeding 100 feet per minute on any passenger. The ventilating mode shall provide air at a minimum flow rate of 20 cfm per actual onboard passenger.

Airflow may be reduced to 15 cfm per actual onboard passenger when operating in the heating mode. The fans shall not activate until the heating element has warmed sufficiently to assure at least 70°F air outlet temperature. The heating air outlet temperature shall not exceed 120°F under any normal operating conditions.

2.2.16.3.2 Driver's Area

The bus interior climate control system shall deliver at least 100 cfm of air to the operator's area when operating in the ventilating and cooling modes. Adjustable nozzles shall permit variable distribution or shutdown of the airflow. Airflow in the heating mode shall be reduced proportionally to the reduction of airflow into the passenger area.

The windshield defroster unit shall meet the requirements of SAE Recommended Practice J382 "Windshield Defrosting Systems Performance Requirements", and shall have the capability of diverting heated air to the operator's feet and legs. The defroster or interior climate control system shall maintain visibility through the operator's side window. Use of electric resistance heat for windshield defroster shall be minimized as much as feasible.

2.2.16.4 Driver's Compartment Requirements

A separately-controlled heating, ventilation, and defroster system for the operator's area shall be provided and shall be controlled by the operator. The system shall meet the following requirements:

- 1) The heater and defroster system shall provide heating for the operator and heated air to completely defrost and defog the windshield, operator's side window, and the front door glasses in all operating conditions. Fan(s) shall be able to draw air from the bus body interior and pass it through the defroster system and to the operator's area. A minimum capacity of 100cfm shall be provided. The operator shall have complete control of the heat for their area.
- 2) The defroster supply outlets shall be located at the lower edge of the windshield. These outlets shall be durable and shall be free of sharp edges that can catch clothes during normal daily cleaning. The system shall be such that foreign objects such as coins or tickets cannot fall into the defroster air outlets. Adjustable ball vents shall be provided at the left of the operator's position to allow direction of air onto the side windows.

A ventilation system shall be provided, which can be integrated as part of the defroster system, to ensure operator comfort and shall be capable of providing fresh air in the foot and/or head areas. Vents shall be controllable by the operator from the normal driving position. Decals shall be provided indicating "operating instructions" and "open" and "closed" positions as well. When closed, vents shall be sealed to prevent the migration of water or air into the bus.

The requirements for operator's cooling shall be consistent with specifications noted. There shall be no dedicated evaporator for drivers cooling.

2.2.16.5 Controls for the Climate Control System (CCS)

The operational modes of the interior climate control system shall be controlled by a 2-position toggle switch conveniently located to the operator. Any under-seat or auxiliary heaters, if used, shall be operated by this switch.

The controls for the operator's compartment for heating, ventilation, and cooling systems shall be integrated and shall meet the following requirements:

- 1) The operator shall be provided independent control of the defroster and operator's heater. The heat/defrost system shall include an "On-Off" switch located near the main Defroster switch. Controls for the heat/defrost system shall include:
 - MODE: Heat or defrost.
 - TEMP: Air outlet temperature.
 - FAN: Airflow fan speed control (at least two positions).
- 2) All switches and controls shall preclude the possibility of clothing becoming entangled.
- 3) A manually operated control valve shall not be required since the electric heater will not use heated water.

2.2.16.6 Air Filtration

Air shall be filtered before entering the AC system and being discharged into the passenger compartment. The filter shall meet the ANSI/ASHRAE 52.1 requirement for 5% or better atmospheric dust spot efficiency, 50% weight resistance, and a minimum dust holding capacity of 120 grams per 1,000 cfm cell. Air filters shall be easily removable for service and cleanable.

All intake openings shall be baffled to prevent entry of snow, sleet, or water. Moisture drains from air intake openings shall be located to prevent clogging from road dirt.

2.2.16.7 HVAC Service Requirements

Manual or automatically controlled shutoff valves in the refrigerant lines shall allow isolation of the compressor and dehydrator filter for service. To the extent practicable, couplings utilizing O-ring seals shall be used to break and seal the refrigerant lines during removal of major components, such as the refrigerant compressor. The refrigerant compressor shall be semi-hermetic and re-buildable. The condenser shall be located on the roof to efficiently transfer heat to the atmosphere, and shall not ingest air warmed above the ambient temperature by the bus mechanical equipment, or to discharge air into any other system of the bus. All access shall be hinged with captive fasteners.

2.2.16.8 HVAC Fuel System Requirements (If Used)

The following requirements shall be met for any proposed HVAC system which utilizes diesel fuel or Liquid Propane Gas (LPG) as part of its operation.

2.2.16.8.1 General Fuel Tank Requirements (All Fuel Types)

The fuel tank shall be properly sized to provide sufficient fuel for heated operation of the bus for at least 18 hours at -20°F. The fuel tank shall be securely mounted to the coach to prevent movement during coach maneuvers, but shall be easily removable for cleaning or replacement. Removal of the tank shall not be required for refueling.

2.2.16.8.2 Diesel Fuel Tank

If diesel is used, fuel tank shall be equipped with an external, socket head, stainless steel drain plug. It shall be at least a 3/8-inch size and shall be located at the lowest point of the tank. The tank shall have an inspection plate or removable filler neck to permit cleaning and inspection. The tank shall be baffled internally to prevent fuel-splashing noise regardless of fill level.

2.2.16.8.3 Diesel Fuel Lines

Diesel fuel lines shall be rigidly supported and shall be composed of steel tubing where practicable except in locations where flexible lines are specifically required. Flexible fluid lines shall be kept at a minimum and shall be as short as practicable.

Lines shall be routed or shielded so that failure of a line shall not allow fuel or oil to spray on or drain onto any component operable above the auto ignition temperature of the fluid. Flexible lines shall be Teflon hoses with braided stainless steel jackets (except in applications where premium hoses are required) and shall have standard SAE or JIC brass or steel, reusable, swivel, end fittings. Hoses shall be individually supported and shall not touch one another, or any part of the coach. The system shall be equipped with a fuel-priming pump or a check valve fitted in the fuel suction line to aid restarting after fuel filter changes.

2.2.17 ANCILLARY FEATURES

2.2.17.1 Driver's Area

The driver's area shall contain all apparatus and controls necessary for operation of the coach. The layout shall maximize the use of available space and shall employ sound human factors and industrial design principles. The operator's area and equipment shall be designed to ensure safe and optimal performance for operators in the range of the 5th percentile female to the 95th percentile male. The operator's area shall be free of sharp edges, protruding objects, safety hazards and floor obstructions.

Contractor should follow SAE J833, "Human Physical Dimensions," in the design of the Driver's Area. Switches and controls shall be divided into basic groups and assigned to specific areas, in conformance with SAE Recommended Practice J680, Revised 1988, "Location and Operation of Instruments and Controls in Motor Truck Cabs," and be essentially within the hand reach envelope described in SAE Recommended Practice J287, "Driver Hand Control Reach."

The driver's work area shall be designed to minimize glare to the greatest extent possible. Objects within and adjacent to this area shall be matte black or dark gray in color wherever possible to reduce the reflection of light onto the windshield. The use of polished metal and light-colored surfaces within and adjacent to the driver's area shall be avoided.

Bidder shall submit drawings detailing the layout of the Driver's Area including controls and instrumentation.

2.2.17.1.1 Dash Panels

To the extent practical, areas that are visible from outside the coach in the vicinity of the dash panel and cowl shall be configured to preclude use for storage of items. The dash panel shall be designed so that liquid spilled on the surface will not damage or interfere with the operation of components or back panel wiring. The dash panel face shall be constructed of painted flat black metal, colored flat black composite material, or black acrylic plastic, designed to last the life of the bus and not degrade due to weathering or exposure to sunlight. The dash panel face shall be arranged to facilitate replacing switches or repairing wiring. The dash panel cabinet shall match adjacent lining materials.

Provide and install a single driver's dash fan. Procuring Agency shall have option to purchase dual driver's fans.

2.2.17.1.2 Sun Shades

Two adjustable Silent Gliss (or approved equal) sun shades shall be provided for the operator's side. Sun shade on driver's side window shall have a vertical split for mirror viewing. The sun shades shall be shaped to minimize light leakage between the visors and windshield pillars. Sun shades shall be stored out of the way and shall not obstruct airflow from climate control system or interfere with other equipment such as radio headset or destination sign controls. Deployment of the sun shades shall not restrict vision of the rear view mirrors. Sun shade adjustment shall be made easily by hand with positive locking releasing devices and shall not be subject to damage. Sun shade construction and materials shall be strong enough to resist breakage during adjustments. Sun shades shall not allow a visible light transmission in excess of 10%. The sun shades, when deployed, shall be effective in the operator's field of view at angles more than 5° above horizon.

Procuring Agency shall have option to remove sun shade from right side of windshield.

2.2.17.1.3 Passenger Stop Request/Exit Signal

A passenger chime signal audible to the driver and to passengers anywhere inside the coach shall be provided. The chime shall be activated by yellow pull cords located in the passenger seating area. Yellow tape switches shall be located adjacent to the mobility aid locations or, if “flip up” seats are used, on the underside of the seats for use by passengers with disabilities. Tape switches located adjacent to wheelchair or mobility aid securement areas shall be mounted no higher than 48 inches and no lower than 15 inches above the floor. Tape switches shall require a force of 5 pounds or less to activate the chime signal.

A “Stop Requested” passenger sign shall be mounted in a position visible to the seated operator and seated passengers. The sign shall be illuminated when the passenger chime signal is activated and shall remain illuminated until one of the passenger doors is opened. The sign shall normally appear white when not illuminated and when activated the sign letters shall be white on a black background. The passenger chime shall sound only once when the sign is first illuminated. The chime for the mobility aid passenger locations shall chime twice and not be prevented from activation when the initial single chime was activated from another location. A driver-controlled switch shall deactivate both chime systems.

2.2.17.1.4 Operator’s Storage

Contractor shall provide an operator’s storage box. Storage box door shall have latches. Keyed door locks will not be accepted. The proposal shall show the location and size of the operator’s storage box.

2.2.17.2 Mirrors

2.2.17.2.1 Exterior Mirrors (Electrically Remote Controlled and heated)

The coach shall be equipped with two Safe Fleet 8” x 15” two-piece (or approved equal) outside review mirrors mounted on both sides of the coach. Mirrors and brackets shall be corrosion-resistant and mounted with stable supports to minimize vibration. Mirrors shall be firmly attached to the bus to minimize vibration and to prevent loss of adjustment with a breakaway mounting system. Mirrors shall permit the driver to view the roadway along the sides of the bus, including the rear wheels. Mirrors should be positioned to prevent blind spots. Mounting shall be sufficient to prevent damage to coach or its structure when the mirror is struck in an accident. Mirror brackets shall be stainless steel. Mirrors shall retract or fold sufficiently to allow coach-washing operations.

All exterior mirrors shall be heated, electronic units and button controls shall be used for remote positioning of both mirrors. The driver shall be able to adjust the mirrors on both sides of the bus remotely while seated in the driving position.

2.2.17.2.2 Interior Mirrors

Mirrors shall be provided for the driver to observe passengers throughout the coach without leaving their seat and without shoulder movement. With a full standee load, including standees in the vestibule, they shall be able to observe passengers in the front and rear step wells, anywhere in the aisle, and in the rear seats. Interior mirrors shall not be in the line of sight to the right outside mirror. Interior mirror shall be 8" x 15" with protected edges.

There shall be a 12" convex mirror mounted inside to the upper right side of the rear entrance door to enable the driver to see inside the step well from the driver seat through the above interior mirror.

2.2.17.3 Passenger Assists

2.2.17.3.1 General Requirements

Passenger assists in the form of full grip, vertical stanchions or handholds shall be provided for the safety of standees and for ingress/egress. Passenger assists shall be convenient in location, shape, and size for both the 95th percentile male and the 5th percentile female standee. Starting from the entrance door, moving anywhere in the coach and out the exit door, a vertical assist shall be provided either as the vertical portion of a seat back assist or as a separate item. They shall be designed so that a 5th percentile female passenger may easily move from one assist to another using one hand and the other without losing support.

The assists shall be between 1¼ and 1½ inches in diameter or width with radii no less than ¼ inch and shall permit a full hand grip with no less than 1½ inches of knuckle clearance around the assist. A crash resulting in a 1-foot intrusion shall not produce sharp edges, loose rails, or other potentially dangerous conditions associated with a lack of structural integrity of the assist. Any joints in the assist structure shall be underneath supporting brackets and securely clamped to prevent passengers from moving or twisting the assists. All areas of the passenger assists that are handled by passengers including functional components used as passenger assists, shall be stainless steel. Assists shall withstand a force of 300 pounds applied over a 12-inch lineal dimension in any direction normal to the assist without permanent visible deformation. All passenger assist components, including brackets, clamps, screw heads, and other fasteners used on the passenger assists, shall be designed to be vandal-proof and designed to eliminate any pinch points, snagging, and cutting hazards and shall be free from burrs or rough edges. Allen-headed fasteners are considered to meet this requirement. All passenger assists, this section notwithstanding, shall comply with the ADA requirements outlined in 49 CFR Part 38.29.

2.2.17.3.2 Front Door

Front door assists shall be as far outward as practical, but shall be no further than 6 inches inward from the outside edge of doorway tread and shall be easily grasped by a 5th percentile female boarding from street level. Door assists shall include a vertical section at the outboard door edge and an upward slope across the door panel that is functionally continuous with the horizontal front passenger assist and the vertical assists on the modesty panels. Door entry assists shall be no less than $\frac{3}{4}$ -inch in width and provide a minimum knuckle clearance of $1\frac{1}{2}$ inches.

2.2.17.3.3 Vestibule

The aisle side of the driver's barrier shall be fitted with a vertical passenger assist that is functionally continuous with the overhead assist and that extends to within 36 inches of the floor. The assist shall have sufficient clearance from the barrier to prevent inadvertent wedging of a passenger's arm. A horizontal passenger assist shall be located across the front of the coach and shall prevent passengers from sustaining injuries on the fare collection device or windshield in the event of a sudden deceleration. Without restricting the vestibule space, the assist shall provide support for the boarding passenger from the front door through the fare collection procedure. Passengers may be able to lean against the assist for stability while paying fares. The assist shall be no less than 36 inches above the floor.

2.2.17.3.4 Front Wheel Housings

The front wheel housings shall have vertical assists at the rearmost aisle-side corners that are continuous with the overhead horizontal assists. A horizontal assist approximately 36 inches above the floor and on top of the wheel housing shall be installed along the aisle side of the curbside wheel housing. A similar assist shall be provided on the streetside wheel housing if it does not preclude opening the doors of the electronics locker.

Where applicable, passenger assists shall be provided around exposed sides of propulsion compartments.

2.2.17.3.5 Overhead

A continuous, full grip, overhead assist shall be provided on both sides of the aisle. This assist shall be convenient to standees anywhere in the coach and shall be located over the center of the aisle seating position of the transverse seats. The assist shall be no less than 70 inches above the floor except over the curbside front wheel housings where the height shall be no less than 60 inches. A similar assist shall be provided over the streetside wheel housing if it does not preclude opening the doors of the electronics locker. Overhead assists shall simultaneously support 150 pounds on a 12-inch length. No more than 5% of the full grip feature shall be lost due to assist supports.

2.2.17.3.6 Seats

Longitudinal seats shall have vertical assists located between every other designated seating position except for seats that fold/flip up to accommodate wheelchair securement and the two most rearward seats on each side, which shall have vertical assists at the rearward edge. Assists shall extend from near the leading edge of the seat and shall be functionally continuous with the overhead assist.

Every other transverse seat shall have a vertical assist attached to the seat back assist extending to the overhead assist. In addition, seats rearward of the mobility aid parking area shall have vertical assists. Assists shall be staggered across the aisle from each other where practical, shall be no more than 52 inches apart, and shall be functionally continuous for a 5th percentile female passenger.

2.2.17.3.7 Rear Step Area

Assists shall be provided on both sides of the aisle steps in the rear of the bus. Assists shall be no less than 36 inches above the floor and step tread surface, and shall be functionally continuous with vertical assists in the low floor area and on the modesty panels in the high floor area.

2.2.17.4 Exterior Route Displays

2.2.17.4.1 Electronic Destination Signs

A destination sign system shall be furnished on the front, right side near the front door. All signs shall be controlled via a single human-machine interface (HMI). In the absence of a single mobile data terminal (MDT), the HMI shall be conveniently located for the bus driver within reach of the seated driver.

Destination signs shall be Twin Vision "Smart Series" or approved equal and, in interest of standardization, shall utilize the following components (or approved equals):

- 1) Front Destination sign
- 2) Side Destination sign
- 3) Driver's Membrane pad control console and display
- 4) All cables and accessories

The Front Destination Sign shall be 16x160 matrix configuration. Sign shall be mounted on the front of the bus near the top edge of the body, behind windshield protection, and in an enclosed but accessible compartment provided by the bus manufacturer.

The Side Destination Sign shall be 14x112 matrix configuration. Sign shall be located on the right side of the bus near the front door, either mounted near the top of an existing window or in a separate enclosed but accessible weather-proof compartment provided by the bus manufacturer.

The entire display area of all signs shall be readable in direct sunlight, at night, and in all lighting conditions between those two lighting extremes, with evenly distributed illumination appearance to the un-aided eye.

Flash memory integrated circuits shall be capable of storing and displaying up to 10,000 message lines. Message memory shall be changeable by the use of a USB drive of not less than one (1) megabyte memory capacity but sized according to the message listing noted herein.

The system shall have the ability to sequentially display multi-line destination messages, with the route number portion remaining in a constant "on" mode at all times, if so programmed. It shall also be capable of accepting manual entry of route alphanumeric information on any or all signs.

The various signs shall be programmable to display independent messages or the same messages, and up to two destination messages and one public relations message shall be pre-selectable. The operator shall be able to quickly change between the pre-selected messages without re-entering a message code. Public relations messages shall be capable of being displayed alternately with the regular text and route messages or displayed separately.

An emergency message shall be activated by a push button or toggle switch in a location to be approved by the Procuring Agency. The emergency message shall be displayed on signs facing outside the vehicle while signs inside the vehicle, including the OCU display, shall remain unchanged. The emergency message shall be canceled by entering a new destination code or by power cycling (after removal of the emergency signal).

The programming software shall provide means of adjusting the length of time messages are displayed in 0.1 second increments up to twenty-five seconds.

Power to the sign system shall be controlled by the "Master Coach Run Switch". The signs shall operate in all positions of this switch except "Off", wherein the sign will only operate for 30 minutes after the master switch is turned off. The signs shall internally protect against voltage transients and Radio Frequency Interference (RFI) to ensure proper operation in the local environment.

2.2.17.4.2 Display and Display Illumination

All sign displays shall consist of pixels utilizing High Intensity Light Emitting Diodes (LED) for superior outdoor environmental performance, with White illumination appearance and light wavelength of 590nm. LED lighting should be made using Aluminum Indium Gallium Phosphide (AlInGaP) II material and superior UV-resistant Epoxy lens, with superior resistance to the effects of moisture. Each pixel shall have a dedicated LED for illumination of that pixel in all lighting conditions. The sign system shall have multi-level intensity changes, which adjust automatically as a function of ambient lighting conditions. There shall be no requirement for any fan or any specialized cooling or air circulation.

LEDs shall be mounted such as to be visible directly to the observer positioned in the viewing cone, allowing for full readability 65 degrees to either side of the destination sign centerline. LEDs shall be the only means of illumination of the sign system. The LED illumination source shall have an operating life mean time between failures (MTBF) of not less than 100,000 hours. Each LED shall not consume more than 0.02 Watts.

The characters formed by the system shall meet the requirements of the Americans with Disabilities Act (ADA) of 1990 Reference 49 CFR Section 38.39.

2.2.17.4.3 Sign Enclosures

All Signs shall be enclosed in a manner such as to inhibit entry of dirt, dust, water and other contaminants during normal operation or cleaning. Access shall be provided to clean the inside of the bus window(s) associated with the sign and to remove or replace the sign components. Access panels and display boards shall be mounted for ease of maintenance and replacement. Rear sign enclosure shall be made of Polycarbonate material containing fiberglass reinforcement. The vehicle manufacturer shall comply with the sign manufacturer's recommended mounting, mounting configuration, and installation procedures to assure optimum visibility and service accessibility of the sign system and system components.

2.2.17.4.4 Electronic System Requirements

All electronic circuit boards used in the sign system shall be conformal coated to meet the requirements of military specification MIL-I-46058C. All sign system components shall be certified to have been subjected to a "burn-in" test of a minimum of twelve (12) hours operation in a temperature of 150 °F prior to final inspection.

2.2.17.4.5 Front Destination Sign

The Front Destination Sign message shall be readable by a person with 20/20 vision from a distance not less than 350 feet for signs with display heights greater than 8

inches, and from a distance not less than 275 feet for display heights less than 8 inches. The Front Destination Sign shall have a viewing cone of equal readability of 65° to either side of a line perpendicular to the center of the mean plane of the display. The intensity of the illumination of the display pixels shall appear (to the naked eye) to be approximately uniform throughout the full viewing cone.

Provide electric defroster grid (automotive type) for the Front Destination Sign glass to help defrost the front glass.

2.2.17.4.6 Side Destination Sign

The Side Destination Sign message shall be readable by a person with 20/20 vision from a distance of not less than 110 feet. The Side Destination Sign shall have a viewing cone of equal readability of 65° to either side of a line perpendicular to the center of the mean plane of the display. The intensity of the illumination of the display pixels shall appear (to the naked eye) to be approximately uniform throughout the full viewing cone.

2.2.17.4.7 Operator Control Unit (OCU)

The OCU shall be used to view and update display messages. It shall be recess-mounted on the vehicle front sign compartment access cover or door. The OCU shall utilize a multi-key conductive rubber pad keyboard and be designed for transit operating conditions.

The OCU shall contain a display of at least two-lines of 20-character capability. The OCU shall contain an audio annunciator that beeps indicating that a key is depressed. The OCU shall continuously display the message associated with the selected destination readings (except the emergency message feature as noted above).

If the Input/Output Buffer Information Specification (IBIS) interface is required in the destination sign system, an auxiliary RS232 (DB9) port shall be made optionally available on the OCU under frame for inputs from any wireless technology that might be envisioned in the future. This auxiliary RS232 port shall operate at 9600 baud, accept commands from a wireless source (such as Spread Spectrum receivers), and set destination sign addresses as if manually operated by the OCU operator.

If the J1708 interface is selected for the destination sign system, an auxiliary J1708 port shall be made available on the J1708 OCU so that auxiliary J1708 commands may be provided to the destination sign system from a wireless source that conforms to the J1708 command structure. Twin Vision does not provide a wireless apparatus, but the Twin Vision destination sign system has the capability of interfacing via the J1708 link

with any such inputs, providing that the apparatus conforms with the appropriate signaling specifications.

2.2.17.4.8 Programming

Manufacturer's basic programming software package shall be submitted as part of the proposal.

On-board programming shall be configured with agency-specific programming installed on all buses prior to release for delivery. Manufacturer shall contact Procuring Agency prior to programming so that the most suitable software version is installed to ensure maximum commonality with software in use by Procuring Agency at time of delivery.

Agency-specific programming software package shall also be provided to Procuring Agency at time of delivery with the USB memory drive according to Agency's program list.

2.2.17.4.9 Message Memory Transfer and Update

The sign system shall be re-programmable on the vehicle with the use of a USB drive. A USB drive shall be provided on the OCU face for this purpose. The maximum reprogramming time for a 10,000-line listing shall be one minute. USB drives, with appropriate memory capacity based on the requirements of the message listing noted below shall be supplied at the rate of two drives per Procuring Agency for this contract.

2.2.17.4.10 Message Listing

Within 14 days of receipt of the first purchase order from Procuring Agency, the vehicle manufacturer shall supply to the sign manufacturer a list of the message readings or listings to allow the sign system to be pre-programmed with the correct readings.

2.2.17.5 Lift System

2.2.17.5.1 General

The design and construction of the bus shall be in accordance with all requirements defined in 49 CFR Part 38, Subpart B: "ADA Accessibility Specifications for Transportation Vehicles – Buses, Vans and Systems" as well as 36 CFR Part 1192. Space and body structural provisions shall be provided at the front of the bus to accommodate the wheelchair loading system.

The wheelchair loading system shall be an automatically controlled, power-operated ramp system, compliant with the requirements defined in 49 CFR Part 38.23(c). Loading system shall provide ingress and egress quickly, safely, and comfortably, both in

forward and rearward directions, for a passenger in a wheelchair from a level street or curb. All exposed surfaces shall be fabricated from stainless steel.

Space and body structural provisions shall be provided at the front door of the coach to accommodate the mobility aid, loading ramp. The ramp and mechanism shall be protected from collision damage; damage from curbing the coach; corrosion; and the entrance of water, sand, and salt. The mobility aid ramp shall provide safe, comfortable, and rapid ingress and egress for passengers using mobility aid devices either from street level or curb. The system shall be designed to operate in a service area environment where curb heights may reach 14 inches and with varying degrees of road crowns. The ramp shall be designed to protect the device from damage and persons on the sidewalk from injury during the extension and lowering phase of operation. The mobility aid ramp system shall not present a hazard or inconvenience to any passenger. In the stored position of the ramp, no tripping hazards shall be present, and any resulting gaps shall be minimized.

2.2.17.5.2 Design Requirements

The ramp shall be located at the front door, with the ramp being of a simple hinged, flip-out type design. The ramp shall be a Ricon FR2 4:1 or approved equal. Ramp shall support a load of 600 pounds, placed at the center of the ramp distributed over an area of 26 inches by 26 inches, with a safety factor of at least 3 based on the ultimate strength of material. The wheelchair lift control system must be capable of receiving multiplex command from vehicle interlocks.

Ramps shall have the least slope practicable and shall not exceed 1:6 slope when deployed to roadways or curb-height boarding and alighting areas when the vehicle is resting on a flat surface. When deployed to a boarding platform with the vehicle resting on a flat surface, slope shall be 1:8 maximum.

The loading platform shall be covered with a replaceable or renewable, non-skid material and shall be fitted with barriers at least 2 inches high to prevent the mobility aid devices from rolling off the ends or sides during loading or unloading. The ramp shall be firmly attached to the vehicle and no gap between the ramp, including its sections, and the vehicle shall exceed 5/8 inch. The ramp shall be furnished with anti-skid tape which has an adhesive backed laminate. The ramp shall not have protrusions from the surface greater than 1/4-inch high and shall have a clear width of 30 inches.

2.2.17.5.3 Ramp Operation

The loading operation shall be under the surveillance and complete control of the operator. Stowing or deploying the ramp shall require two separate and distinct actions by the operator. A guarded master switch in the operator's console shall disable ramp

operation. The controls shall be simple to operate with no complex phasing operation required and should be integrated with the coach kneeling system to minimize slope from ramp to street level. The four-way hazard warning lights shall be automatically activated when the ramp master switch is in the enabled or on position at the operator's console. The ramp shall be incapable of stowing when a passenger is on the ramp. The safeguards incorporated into the ramp's operation to prevent accidental stowing of the ramp with a passenger on the ramp shall not cause damage to the ramp or mechanism. The coach shall be prevented from moving during ramp system operation by a throttle and brake interlock. The device shall function without failure or adjustment other than normal maintenance for 500 cycles or 30,000 miles in all weather conditions encountered in Vermont climate. In the event of a ramp malfunction, the ramp shall be able to be manually deployed or stowed by the operator without the need for tools or equipment.

2.2.17.5.4 Securement System

Flip-seats in wheelchair locations shall match the model and material of the rest of the passenger seating. All components used in the securement system shall conform to the requirements of the Americans with Disabilities Act and the Federal Motor Vehicle Safety Standards.

Securement areas shall be a minimum 30 inches x 48 inches as required by ADA. All buses shall be equipped with Q-Straint wheelchair securement system or approved equal. The "H Sliding Arm" restraint system shall be installed with Q-Straint retractable belts and remote pull handles with 2 rear belts and 2 retractors. Accommodations for two (2) wheelchair passengers shall be provided, including passenger seat belts, lap belts, wheelchair securement straps, and fold down seats. Passenger's personal restraint seat belts shall be of sufficient length to accommodate passengers in electric powered wheelchairs. All belt assemblies must stow up and out of the way to prevent a passenger safety hazard and the system shall comply with the ADA requirements outlined in 49 CFR Parts 27,37, and 38. All hardware parts which contact, under normal usage, a person, clothing, or webbing shall be free from burrs and sharp edges.

2.2.17.6 Pleasure Radio

Vehicle shall be equipped with a REI FM radio with built in PA function, without removable face plate. Radio shall be mounted above driver barrier storage box area. It shall be equipped with auto PA override. Antenna shall be a Metra 44-US01R. 8 rear ceiling mounted passenger speakers (four per side) and 1 driver overhead speaker. A separated driver volume (rheostat) switch shall be mounted on driver left side switch panel.

2.2.17.7 P.A. System R.E.I

A driver select toggle switch (Inside/Both/Outside) located on the left side driver switch panel shall be included with the Pleasure radio system with 1 outside speaker and a driver boom microphone located above driver, a foot control P.A. on/off switch shall be provided.

2.2.17.8 Two Way Radio/AVL

A Kenwood NX800N two way radio and a Fleetwave VP390 AVL shall be used along with a roof mounted antennas. A radio provided mount pad on dash within close proximity of driver controls. All wiring and antenna cables shall be preinstalled, a 20 amp fuse, 12-volt battery supply; 12-volt ignition supply, and negative ground circuits shall be provided. Vendor Burlington Communications shall install and program radio and AVL units, contact: todd.goad@burlingtoncommunications.com phone (802) 862-7092

2.2.17.9 Auxiliary Power Supply

A 12 volt battery supply recessed connection at or near right side of dash shall be provided

2.3 Chassis/Power Plant

2.3.1 POWER PLANT OPERATING REQUIREMENTS

2.3.1.1 Power Requirements

The propulsion system components shall be sized to provide sufficient power to enable the bus to meet the defined acceleration, top speed, and gradeability requirements, and operate all accessories using actual road test results and computerized vehicle performance data.

The loss of power to the bus shall not cause the driver to lose control of the bus or to lose steering or braking. The bus shall be able to be safely brought to a controlled stop. The bidder should provide propulsion system specifications along with drive train/gear specifications (if any).

2.3.1.2 Top Speed

Top bus speeds will be set independently by Procuring Agency following award. The expectation is that the bus shall be capable of achieving a top speed of 65 mph on a straight, level road at GVWR with all accessories operating. The bus shall be capable of safely maintaining the vehicle speed according to the recommendations by the tire manufacturer.

2.3.1.3 Gradeability

Gradeability requirements shall be met on grades with a dry commercial asphalt or concrete pavement at GVWR with all accessories operating. The propulsion system shall be required to enable the bus to achieve a speed of 40 mph on a 2.5% ascending grade and 15mph on a 10% ascending grade.

2.3.1.4 Acceleration

The acceleration shall meet the requirements below and shall be sufficiently gradual and smooth to prevent throwing standing passengers off-balance. Acceleration measurement shall commence when the accelerator is depressed.

Maximum Start Acceleration Times on a Level Surface (assumes GVWR)¹

Speed (mph)	Maximum time (seconds)
10	5
20	10
30	20
40	30
50	60
Top Speed = 65 mph	

2.3.1.5 Operating Range

The operating range of the bus shall be designed to meet the Design Operating Profile.

The operating range of the bus with full state of charge shall be at least 160 miles. Bidder shall include a calculation of operating range by identifying the bus's Usable Battery Capacity divided by its Overall Average Consumption fuel efficiency recorded at Altoona.

2.3.1.6 Fuel Economy

Test results from the Altoona fuel economy tests or other applicable test procedures shall be provided to the Procuring Agency. Results shall include vehicle configuration and test environment information. Fuel economy data shall be provided for each design operating profile and should be provided in miles per kWh. The design operating profile for this test is assumed to be defined by the Altoona fuel duty cycle.

Fuel economy tests shall be run on these three duty cycles: CBD, Arterial, and Commuter.

2.3.2 PROPULSION SYSTEM REQUIREMENTS

2.3.2.1 General

The bus shall be powered by a battery electric propulsion system. The propulsion system shall be specifically adapted for transit bus duty cycle that includes start and stop operation. In addition to power required for propulsion, sufficient excess power shall be available to operate all accessories at their normal operating condition throughout the transit bus duty cycle.

The Contractor shall assure that the bus structure can successfully accept the installation of the propulsion system and be operated on the stated duty-cycle for a period of 12-years without a structural failure. The propulsion system shall be designed to require no major overhaul to achieve this lifetime. A major overhaul consists of the concurrent replacement, due to wear, of major components.

The propulsion system shall comply with applicable local, state, and/or federal emissions and useful life requirements, as a zero emission bus. The propulsion system shall be rated for the GVWR or greater of the bus.

2.3.2.2 Propulsion System Components

The propulsion system includes an electrical energy storage system (ESS), propulsion control system (PCS), power-conditioning components, an appropriately sized permanent magnet (PM) traction motor, and the drive train to the driving wheels.

2.3.2.3 Propulsion Control System (PCS)

The Propulsion Control System (PCS) regulates energy flow throughout the system components in order to provide motive performance and accessory loads, as applicable, while maintaining critical system parameters (e.g., voltages, currents, temperature, etc.) within specified operating ranges. The controller shall monitor and process inputs and execute outputs as appropriate to control the operation of all propulsion system components.

The Traction Motor shall be equipped with an electronically controlled management system, compatible with 12-volt power distribution. The motor control system shall be capable of transmitting and receiving electronic inputs and data from other drivetrain components and broadcasting that data to other vehicle systems. Communication between electronic drivetrain components and other vehicle systems shall be made using the communications networks.

The battery electric drive system shall have onboard diagnostic capabilities able to monitor vital motor functions, store and time stamp parameter conditions in memory, and communicate faults and vital conditions to service personnel. Diagnostic reader device connector ports, suitably protected against dirt and moisture, shall be provided in the operator's area. The onboard diagnostic system shall inform the operator via visual and/or audible alarms when out of parameter conditions exist for vital electric drive train functions. The on-board diagnostic system shall have capabilities for storing hard and soft codes and processing data and provide detailed information/reports on various aspects of fleet usage. The information shall be retrievable via cabling or wireless transmission to a laptop.

The motor drive shall protect the drive system against progressive damage. The system shall monitor conditions critical for safe operation and automatically de-rate power and/or speed and initiate motor shutdown as needed. The on-board diagnostic system shall trigger a visual and audible alarm to the operator when the motor control unit detects a malfunction and the electric drive train protection system is activated. Automatic shutdown shall only occur when parameters established for the functions below are exceeded:

- Over Temp
- Inverter Fault
- Over Voltage
- Broken Wire
- Loss of Electrical Communications
- Communications Safety
- No redundant bus manufacturer and/or component manufacturer "detection and shutdown" circuits. By default, the component manufacturer's software shall be used to record fault codes.

A control shall be available to the operator to allow a 30-second override, which, when depressed, will allow the operator to delay the drive system shutdown but not the activation and alarm system.

2.3.2.4 Regenerative Braking

The bus shall have a regenerative braking system to aid in the reduction of wear on the brakes and to help extend the range of the vehicle through energy recapture. The vehicle will employ regenerative braking as the accelerator pedal is completely released. Regenerative braking shall be additionally increased as the brake pedal is applied which shall also increase service brake application.

Actuation of Anti-Lock Braking System (ABS) and / or Automatic Traction Control (ATC) shall override the operation of regenerative brake. Disengaging regenerative braking should be at the discretion of the bus operator.

The ABS shall include a means of maintaining dynamic braking (braking retardation) as the ESS approaches 100% SOC, i.e., designed to prevent overcharging of the batteries.

2.3.2.5 Transmission

Buses may be proposed with or without a transmission. Demonstration of the benefits to the inclusion or absence of a transmission in the bus build must be definitively established in the Proposal.

2.3.2.6 Propulsion System Service

The Traction Motor shall be designed to operate for not less than 300,000 miles without major failure or significant deterioration. Components of the control system shall be designed to operate for not less than 150,000 miles without replacement or major service.

The propulsion system shall be arranged so that accessibility for all routine maintenance is assured. No special tools, other than dollies and hoists, shall be required to remove the propulsion system or any subsystems. However, Procuring Agency shall recognize that properly rated test equipment and safe electrical work practices are essential when servicing high voltage components. Contractor shall provide all specialty tools and diagnostic equipment required for maintaining the Propulsion System.

2.3.3 ENERGY STORAGE / BATTERY SYSTEM (ESS)

2.3.3.1 General

An overview of the design and performance of the Energy Storage System (ESS) shall be provided to Procuring Agency. The ESS shall be capable of operating in the Procuring Agency's transit environment. The ESS shall be designed, sized, and selected to ensure that the vehicle performance specifications, compatibility with charging, and other related requirements are met or exceeded, bearing in mind cost benefit and reliability variables as they relate to the characteristics of the different battery types. The power source for the vehicle shall be derived from established battery technology that has a field-proven track record of safe, reliable, and durable operation in similar applications.

The ESS design, including containers, module bracing systems, thermal-management systems, battery management systems, watering/venting systems, interconnections, fusing, and traction-controller should be completely described in the proposal.

The proposal shall include a detailed analysis of expected battery performance in the Design Operating Profile. The proposal should also include a comprehensive statement of the warranty terms relating to the battery, including explanation of all disclaimers within the warranty. The charge cycle and cycle life should be stated in the proposal and a life cycle cost analysis of the proposed battery system in the specified application should be provided.

The battery system shall be capable of withstanding the high current and voltage profiles necessary to accomplish daily recharge events without reducing the life of the battery.

2.3.3.2 Charging Requirements

The primary charging of the energy storage system shall be accomplished by conductive charging as needed to meet the required duty cycle. The energy storage system shall also make use of regenerative braking. The Energy Storage System shall comply with UN/DOT 38.3 requirements for lithium batteries or similar standards for non-lithium batteries.

The Contractor shall deliver the buses with an installed, fully-charged, functioning ESS. The ESS shall be fully formed, installed and tested in accordance with the battery manufacturer's recommended practices.

Contractor shall deliver any proprietary EVSE needed to charge the buses to a location of the Procuring Agency's choice.

2.3.3.3 Energy Storage System Safety

The ESS battery packs shall be located outside the passenger compartment and in a position outside of a direct side or rear impact zone. Additionally, the ESS batteries shall be load distributed within the bus to equalize weight between the wheels on the same axles and to achieve appropriate weight distribution between axles so as not to adversely affect handling of the bus.

The bus body shall be purpose-designed and constructed to ensure passengers and the operator will not be exposed to electrical current either in normal operation or in the event of a vehicle accident. Analysis and test data shall be provided to the Procuring Agency. The ESS shall be designed and constructed to prevent gassing or fumes from the ESS from entering the interior of the bus.

Proposals shall include complete descriptions of all safety standards followed in the design and manufacture of the battery system, safety testing procedures used to validate the safety of battery operation in this application, and documented results of safety testing to confirm that standards have been met.

All contactors in the system shall have feedback to allow the system to know if there is a potential for high voltage to be present when it shouldn't be.

2.3.3.4 Battery Thermal Management

Battery thermal management must be powered from an onboard source at all times. Thermal management must be continuously monitored at all times with appropriate safety interlocks installed to react to adverse conditions.

Battery temperatures must never exceed the manufacturer's recommended range during operation in the design operating profile and specified ambient conditions. Battery cooling must be sufficient to prevent the temperature from exceeding the battery manufacturer's recommended maximum temperature when the ambient temperature is above 105 degrees F for a period of 16 hours.

Proposer shall provide detail on cold-weather battery thermal management. Specifically, what heat source will warm the battery, and by what means (e.g. direct heating, water loop, forced air)? What will be the capacity of that heat source? Will the battery be in an insulated compartment, or have integrated thermal insulation? What measures have been taken to prevent battery thermal energy use from reducing vehicle range in cold weather?

2.3.3.5 Battery Management System (BMS)

The BMS shall communicate on the main vehicle Controller Area Network (CAN) bus to interface with the cooling, powertrain, charge and other systems.

The BMS must be capable of monitoring the voltage level of cells within each battery pack. The BMS must be able to read and store individual battery or block voltages at a frequency of 1 data point per block every 15 seconds.

The BMS must monitor battery pack temperatures using no fewer than 2 thermocouples placed in and around each battery pack sampled at intervals no greater than 15 seconds.

The BMS must monitor current imbalance between cells and packs.

The BMS must be capable of communicating when a battery fault (as defined by the battery manufacturer) has occurred and must be able to identify and communicate the faulty battery in order to perform maintenance.

The BMS must be capable of engaging prudent safety interlocks when an unsafe battery condition has been detected.

The BMS must be able to monitor the battery state-of charge and update a gauge viewed by the operator at least once every 15 seconds.

The BMS must be able to communicate all data to the bus level information system for storage and communication.

The BMS must manage traction battery charging to conform to traction battery manufacturer recommendations to maximize life and performance.

The actual charge profiles delivered under control of the BMS while charging, commissioning, equalizing, and conditioning the traction battery shall be recorded by the Contractor and shall be submitted to the battery manufacturer for review and approval. Written confirmation from the battery manufacturer attesting to the appropriateness of the delivered charge profile shall be submitted to Procuring Agency concurrent with or prior to delivery of the first bus.

2.3.3.6 Two-way power flow

As an option, buses should be equipped for two-way power flow. Vehicles should be capable of exporting power to the AC grid. Power exported to the grid should be 3-phase, AC 480 volt and with less than 5% harmonic distortion. Equipment should be UL certified. Bidder should provide example and contact information for transit property that has exported power from vehicle.

Additionally, buses may be equipped with the ability to transfer energy from the traction battery to another vehicle. Bidder should specify whether vehicle-to-vehicle energy transfer is standard, included in a two-way power flow option, or not available.

The price to include this feature shall be shown in the Optional Equipment table.

2.3.4 COOLING SYSTEMS

2.3.4.1 General Requirements

The cooling systems shall be of sufficient size to maintain all motor, drive train systems (if applicable), controller and battery systems at safe, continuous operating temperatures during the most severe operations possible (protected to -40° Fahrenheit) and in accordance with the manufacturers' cooling system requirements. The cooling system fan/fans control should sense the temperatures of the components or operating fluids and the intake air and if either is above safe operating conditions the cooling fan should be engaged. The fan control system shall be designed with a fail-safe mode of "fan on." The cooling system in new condition shall have an ambient capacity of at least 115° F with water as coolant and sea level operation.

2.3.4.2 Drive Train Component Cooling

The Traction Motor shall be cooled by a liquid-based cooling system that does not permit boiling or coolant loss during operation. Cooling fan(s) shall be temperature controlled, preventing the Traction Motor from exceeding manufacturer's recommended operating temperatures. Air vent valves shall be fitted at high points in the cooling system unless it can be demonstrated that the system is self-purging.

A low-level coolant sensor shall be provided and shall be accessible by an exterior access door at ground level. The sensor shall activate a warning light on the dash. The water filler shall be no more than 60 inches above the ground and both shall be accessible through the same access door.

2.3.4.3 Radiators

All radiators shall be of durable corrosion-resistant construction with integral tanks. Plastic tanks are not permitted. All radiators shall be designed so a 2M mechanic can gain access to a substantial portion for the purpose of cleaning the radiators in five minutes or less.

Radiators with a fin density greater than 12 fins per inch, and louvered/slit designs shall not be used.

All hose clamps shall be constant tension type clamps. The radiators shall be designed to withstand thermal fatigue and vibration associated with the installed configuration.

2.3.5 PROPULSION SYSTEM SERVICE & ACCESSORIES

2.3.5.1 Service

The propulsion system components shall be arranged so that accessibility for all routine maintenance is assured. No special tools, other than dollies and hoists, shall be required to remove the Traction Motor. Two 3M mechanics shall be able to remove and replace the Traction Motor and gearbox in 8 hours or less.

Radiator fillers shall be arranged so as to ensure simple, efficient filling while tethering the cap and ensuring the filler is closed when filling is completed. All fluid fill locations shall be properly labeled to help ensure correct fluid is added and all fillers shall be easily accessible with standard funnels, pour spouts, and automatic dispensing equipment. All lubricant sumps shall be fitted with magnetic-type, drain plugs.

2.3.5.2 Hydraulic Systems

Hydraulic system service tasks shall be minimized and scheduled no more frequently than those of other major coach systems. All elements of the hydraulic system shall be easily accessible for service or unit replacement. Sensors in the hydraulic system shall indicate on the driver's diagnostic panel conditions of low hydraulic fluid level and low system operation pressure. Critical points in the hydraulic system shall be fitted with service ports so that portable diagnostic equipment may be connected, or sensors may

be permanently attached for an off-board diagnostic system to monitor system operation.

The hydraulic system shall operate within the allowable temperature range as specified by the lubricant manufacturer.

The hydraulic system shall be of a modular design which can be removed with no more than four bolts.

All hydraulic systems shall be listed in the Proposal.

2.3.5.2.1 Hydraulic Fluid Lines

All lines shall be compatible with the hydraulic fluid and be rated at a working pressure limit that is safely above the maximum pressures encountered by the system. Lines should be stainless steel in all locations where stainless steel is compatible with the substance carried. The lines must be designed and intended for use in the environment where they are installed, i.e., high temperatures, road salts, oils, etc. Lines shall be capable of withstanding maximum system pressures.

All hydraulic line routings shall be supported by click-bond supported fittings and clamps designed for this application. Lines passing through a panel, frame, or bulkhead shall be protected by grommets (or similar device) that fit snugly to both the line and the perimeter of the hole that the line passes through to prevent chafing and/or wear.

All flexible lines shall be as short as practicable, no greater than 6 feet in length, unless demonstrated inappropriate for a given application. Hydraulic lines shall be individually and rigidly supported to prevent chafing damage, fatigue failures, and tension strain on the lines and fittings. The hydraulic system shall be configured and/or shielded so that failure of any flexible line shall not allow hydraulic fluid to spray or drain onto any component operable above the auto-ignition temperature of the fluid. Flexible hoses and fluid lines shall not touch one another, or any part of the bus.

A priority system shall prevent the loss of power steering during operation of the coach if other devices are also powered by the hydraulic system.

Flexible lines shall be compatible with the fluids they are intended to carry, at all expected temperatures and pressures and shall have standard SAE, JIC or ORS stainless steel, swivel, end fittings. Flexible hoses over 1 inch in diameter shall be in conformance with SAE J100R5. Flexible hoses and fluid lines shall not abrade one another, or any part of the bus.

Hydraulic lines of the same size and with the same fittings as those on other piping systems of the bus, but not interchangeable, are tagged or marked for use on the hydraulic system only.

2.3.5.2.2 Fittings and Clamps

Compression fittings shall be standardized as much as practicable to prevent the intermixing of components. Compression fitting components from more than one manufacturer shall not be mixed even if the components are known to be interchangeable.

2.3.5.3 Radiator

Radiator piping shall be stainless steel and, if practicable, rubber hoses shall be eliminated. Necessary hoses shall be EPDM coolant hoses or silicone rubber type with 4-ply polyester fabric reinforcement. Hoses shall meet SAE J20R3 for heavy vehicle applications and shall be used in limited spaces.

All hoses shall be as short as practicable. All hoses shall be secured with constant tension spring clamps made from high tensile spring steel (51CrV4) and treated for 1000-hour ASTM B-117 corrosion resistance. The clamps shall maintain a constant tension at all times, expanding and contracting with the hose in response to temperature changes and aging of the hose material.

2.3.5.4 Oil Lines

Oil lines shall be compatible with the substances they carry. Lines should be stainless steel in all locations where stainless steel is compatible with the substance carried. The lines must be designed and intended for use in the environment where they are installed, i.e., high temperatures, road salts, oils, etc. Lines shall be capable of withstanding maximum system pressures.

Flexible oil lines, where necessary, shall be Teflon hoses with braided stainless steel jackets (except in applications where premium hoses are required) and shall have standard SAE or JIC stainless steel, swivel, end fittings. Hoses shall be individually supported and shall not touch one another, or any part of the coach.

2.3.6 FINAL DRIVE

2.3.6.1 Drive Axle

The bus shall be driven by a single, heavy-duty axle with rear-wheel drive and a load rating sufficient for the bus loaded to GVWR. The drive axle shall have a design life to

operate for not less than 300,000 miles on the design operating profile without replacement or major repairs. The lubricant drain plug shall be magnetic type, external hex head of a standard size. The oil level in the planetary gears shall be easily checked through the fill plug or sight gauge. The axle and driveshaft components shall be rated for both propulsion and retardation modes with respect to duty cycle.

The drive shaft (if applicable) shall be guarded to prevent hitting any critical systems, including brake lines, bus floor or the ground, in the event of a tube or universal joint failure.

2.3.6.2 Automatic Traction Control (ATC)

An Automatic Traction Control (ATC) system shall be installed on each drive axle wheel end to maximize torque to the wheel end having the best traction. The system shall be transparent to the bus operator.

2.3.7 SUSPENSION

2.3.7.1 General Requirements

The front and rear suspensions shall be pneumatic type. The basic suspension system shall last the service life of the bus without major overhaul or replacement. Normal replacement items, such as one suspension bushing, shock absorbers, or air spring shall be replaceable by a 3M mechanic in 30 minutes or less. Adjustment points shall be minimized and shall not be subject to a loss of adjustment in service. Necessary adjustments shall be easily accomplished without removing or disconnecting the components.

All axles shall be properly aligned so the vehicle tracks accurately within the size and geometry of the vehicle.

2.3.7.2 Springs and Shock Absorbers

2.3.7.2.1 Suspension Travel

The suspension system shall permit a minimum wheel travel of 2.75 in. jounce-upward travel of a wheel when the bus hits a bump (higher than street surface), and 2.75 in. rebound-downward travel when the bus comes off a bump and the wheels fall relative to the body. Elastomeric bumpers shall be provided at the limit of jounce travel. Rebound travel may be limited by elastomeric bumpers or hydraulically within the shock absorbers. Suspension shall incorporate appropriate devices for automatic height control so that regard-less of load the bus height relative to the centerline of the wheels does not change more than ½ in. at any point from the height required. The safe

operation of a bus will not be impacted by ride height up to 1 in. from design normal ride height.

2.3.7.2.2 Kneeling

A kneeling system shall lower the entrance(s) of the bus a minimum of 2.5 inches during loading or unloading operations regardless of load up to GVWR, measured at the longitudinal centerline of the entrance door(s), by the driver. The kneeling control shall use a three position, spring loaded to center switch, and provide the following functions:

- Downward control will lower the bus.
- Release of switch at any time shall completely stop the lowering motion and hold height of the bus at that position.
- Upward direction of the switch will allow the system to go to floor height without the driver having to hold the switch up.

Brake and Throttle interlock shall prevent movement when the bus is kneeled. The kneeling control shall be disabled when the bus is in motion. The bus shall kneel at a maximum rate of 1.25 inches per second at essentially a constant rate. After kneeling, the bus shall rise within 5 seconds to a height permitting the bus to resume service and shall rise to the correct operating height within 7 seconds regardless of load up to GVWR. During the lowering and raising operation, the maximum acceleration shall not exceed 0.2g and the jerk shall not exceed 0.3g/sec.

An indicator visible to the driver shall be illuminated until the bus is raised to a height adequate for safe street travel. An audible warning alarm will sound simultaneously with the operation of the kneeler to alert passengers and bystanders. A warning light mounted near the curbside of the front door, minimum 2" diameter, amber lens shall be provided that will blink when the kneel feature is activated. Kneeling shall be operational while the ramp is deployed.

2.3.7.2.3 Damping

Vertical damping of the suspension system is accomplished by hydraulic shock absorbers mounted to the suspension arms or axles and attached to an appropriate location on the chassis. Damping is sufficient to control bus motion to three cycles or less after hitting road perturbations. The shock absorber bushing is made of elastomeric material that will last the life of the shock absorber. The damper incorporates a secondary hydraulic rebound stop.

2.3.7.2.4 Lubrication

All elements of steering, suspension and drive systems requiring scheduled lubrication will be provided with grease fittings conforming to SAE Standard J534. These fittings shall be located for ease of inspection and shall be accessible with a standard grease gun from a pit or with the bus on a hoist. Each element requiring lubrication has its own grease fitting with a relief path. The lubricant specified shall be standard for all elements on the bus serviced by standard fittings and is required no less than every 6,000 miles.

2.3.8 STEERING

2.3.8.1 General

An electrically driven power steering hydraulic pump shall be provided. Hydraulic assisted steering shall be provided to reduce steering effort. The steering gear must be an integral type with the number and length of flexible lines minimized or eliminated.

No element of the steering system shall fail before suspension system components when one of the tires strikes a severe road hazard.

2.3.8.2 Steering Axle

The front axle shall be of an independent suspension design, non-driving with a load rating sufficient for the bus loaded to GVWR and shall be equipped with grease type front wheel bearings and seals.

All friction points on the front axle shall be equipped with replaceable bushings or inserts and lubrication fittings easily accessible from a pit or hoist.

2.3.8.3 Steering Wheel

The steering wheel diameter shall be approximately 18 to 20 in.; the rim diameter is $\frac{7}{8}$ to $1\frac{1}{4}$ in. and shaped for firm grip with comfort for long periods of time.

Steering wheel spokes and wheel thickness ensures visibility of the dashboard so that vital instrumentation is clearly visible at center neutral position (within the range of a 95th-percentile male, as described in SAE 1050a, Sections 4.2.2 and 4.2.3). Placement of steering column is as far forward as possible, and in line with the instrument cluster.

2.3.8.3.1 Turning Effort

Steering effort is measured with the bus at GVWR, stopped with the brakes released on clean, dry, level, commercial asphalt pavement and the tires inflated to recommended pressure.

Under these conditions, the torque required to turn the steering wheel 10° shall be no less than 5 ft-lbs and no more than 10 ft-lbs. Steering torque may increase to 70 ft-lbs when the wheels are approaching the steering stops, as the relief valve activates. Power steering failure shall not result in loss of steering control. With the bus in operation, the steering effort will not exceed 55 lbs. at the steering wheel rim, and perceived free play in the steering system will not materially increase as a result of power assist failure. Gearing shall require no more than seven turns of the steering wheel lock-to-lock.

Caster angle shall be selected to provide a tendency for the return of the front wheels to the straight position with minimal assistance from the driver.

2.3.8.3.2 Steering Column Tilt

The steering wheel shall have a rearward tilt adjustment range of no less than 30 degrees as measured from the horizontal and upright position.

2.3.8.3.3 Steering Wheel Telescopic Adjustment

The steering wheel shall have full telescoping capability and have a minimum telescopic range of 2 in. and a minimum low-end adjustment of 29 in., measured from the top of the steering wheel rim in the horizontal position to the cab floor at the heel point.

TABLE 1

Steering Wheel Height¹ Relative to Angle of Slope

At Minimum Telescopic Height Adjustment (29in.)		At Maximum Telescopic Height Adjustment (5 in.)	
Angle of Slope	Height	Angle of Slope	Height
0 deg	29 in.	0 deg	34 in.
15 deg	26.2 in.	15 deg	31.2 in.
25 deg	24.6 in.	25 deg	29.6 in.
35 deg	22.5 in.	35 deg	27.5 in.

– 1. Measured from bottom portion closest to driver.

2.3.8.4 Turning Radius

TABLE 2

Maximum Turning Radius

Bus Length (approximate)	Maximum Turning Radius (see Figure 4)	Procuring Agency Requirement
30 ft.	29.5 ft. (TR0)	Allow +1 inch
35 ft.	39 ft. (TR0)	Allow +1 inch
40 ft.	44 ft. (TR0)	Allow +0 inch

FIGURE 4
Turning Radius

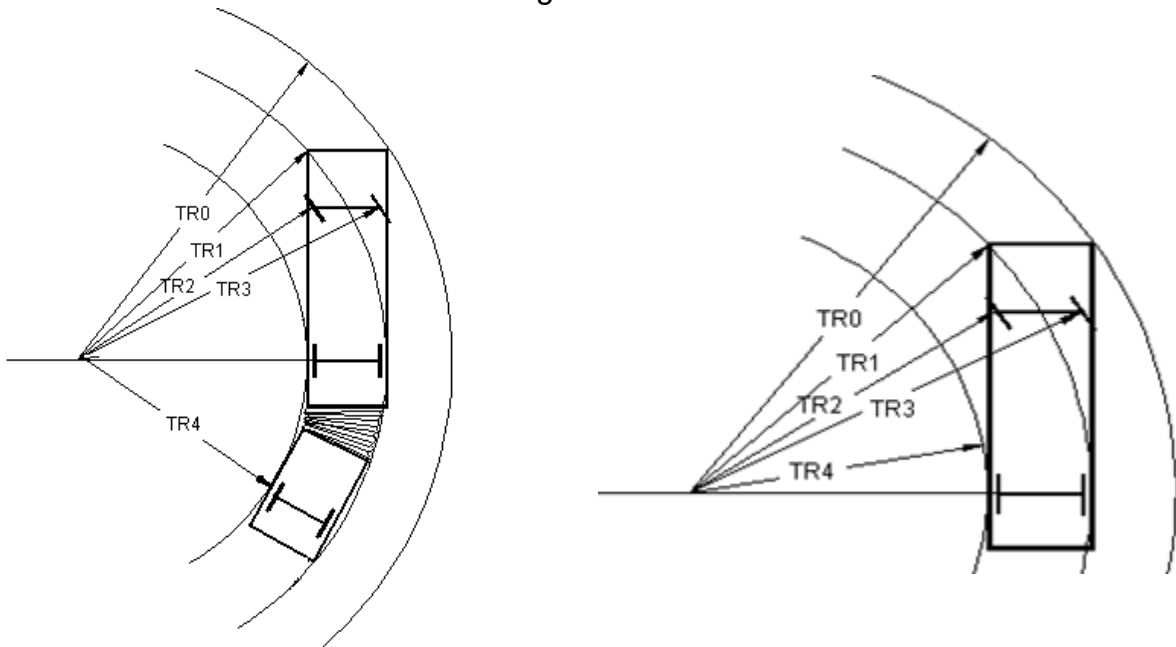

2.3.9 BRAKES

2.3.9.1 Service Brake

The four-wheel disc brakes shall be self-adjusting. Brake wear indicators shall be provided on exposed push rods.

2.3.9.2 Actuation

Service brakes shall be controlled and actuated by a compressed air system. Force to activate the brake pedal control shall be an essentially linear function of the bus

deceleration rate and shall not exceed 70 pounds at a point 7 inches above the heel point of the pedal to achieve maximum braking. The heel point is the location of the driver's heel when foot is rested flat on the pedal and the heel is touching the floor or heel pad of the pedal. A microprocessor controlled Automatic Braking System (ABS) shall be provided. The microprocessor for the ABS system shall be protected yet in an accessible location to allow for ease of service. The total braking effort shall be distributed between all wheels in such a ratio as to ensure equal friction material wear rate at all wheel locations.

2.3.9.3 Friction Material

Friction materials shall have a replacement life of at least 25,000 miles with the regenerative brakes inoperative. Brakes shall be self-adjusting throughout this period. The brake linings shall be made of non-asbestos material. In order to aid maintenance personnel in determining extent of wear, a provision such as a scribe line or chamfer indicating the thickness at which replacement becomes necessary, shall be provided on each brake lining.

2.3.9.4 Hubs and Drums/Discs

Replaceable wheel bearing seals shall run on replaceable wear surfaces or be of an integral wear surface sealed design. Wheel bearing and hub seals shall not leak or weep lubricant for 100,000 miles when running on the design operating profile. The bus shall be equipped with disc brakes on both the front and rear axles and the brake discs shall allow machining the surfaces up to ¼ inch each side to obtain smooth surfaces.

The brake system material and design shall be selected to absorb and dissipate heat quickly so the heat generated during braking operation does not glaze brake linings. The heat generated shall not increase the temperature of tire beads and wheel contact area to more than that allowed by the tire manufacturer.

2.3.9.5 Parking/Emergency Brake

The parking brake shall be a spring-operated system, actuated by a valve that exhausts compressed air to apply the brakes. The parking brake may be manually enabled when the air pressure is at the operating level per FMVSS 121.

An emergency brake release shall be provided to release the brakes in the event of automatic emergency brake application. The parking brake valve button will pop out when air pressure drops below requirements of FMVSS 121. The driver shall be able to manually depress and hold down the emergency brake release valve to release the brakes and maneuver the bus to safety. Once the operator releases the emergency brake release valve, the brakes shall engage to hold the bus in place.

2.3.10 PNEUMATIC SYSTEM

2.3.10.1 General

The bus air system shall operate the air-powered accessories and the braking system with reserve capacity in accordance with FMVSS 121. New buses shall not leak down more than 5 psi as indicated on the instrument panel mounted air gauges, within 15 minutes from the point of governor cut-off.

Provision shall be made to apply shop air to the bus air systems using a quick-disconnect fitting, Tru-Flate design 3/8" air coupler, or approved equal. A quick disconnect fitting specified herein shall be easily accessible and located in the Traction Motor system compartment and near the front bumper area for towing. Retained caps shall be installed to protect fitting against dirt and moisture when not in use. A quarter (1/4) turn manual shutoff valve shall be added behind the fitting. Air for the compressor shall be filtered separately and specifically for the air compressor/intake. Location of fittings will be determined at time of award.

The air system shall be protected by a pressure relief valve set at 150 psi and shall be equipped with check valve and pressure protection valves to assure partial operation in case of line failures.

2.3.10.2 Air Compressor

The air compressor shall be electrically driven and shall be sized to charge the air system from 40 psi to the governor cut-off pressure in less than 4 minutes. A piston type air compressor is not acceptable. Air compressor shall have constant positive intake pressure or be unloaded through the air dryer system.

2.3.10.3 Air Lines and Fittings

Air lines, except necessary flexible lines, shall conform to the installation and material requirements of SAE Standard J1149 for stainless steel tubing with standard, brass, flared or ball sleeve fittings, or SAE Standard J844 for nylon tubing if not subject to temperatures over 200 °F. The air on the delivery side of the compressor where it enters nylon housing shall not be above the maximum limits as stated in SAE J844. Nylon tubing shall be installed in accordance with the following color-coding standards:

- **Green:** Indicates primary brakes and supply
- **Red:** Indicates secondary brakes
- **Brown:** Indicates parking brake
- **Yellow:** Indicates compressor governor signal

- **Black:** Indicates doors, hill hold, and accessories

Line supports shall prevent movement, flexing, tension, strain and vibration. Stainless steel lines shall be supported to prevent the lines from touching one another or any component of the bus. To the extent practicable and before installation, the lines shall be pre-bent on a fixture that prevents tube flattening or excessive local strain. Stainless steel lines shall be bent only once at any point, including pre-bending and installation. Rigid lines shall be supported at no more than 5 ft. intervals. Nylon lines may be grouped and are supported at 30 in. intervals or less.

The compressor discharge line shall be a flexible Teflon hose with a braided stainless steel jacket. Other lines necessary to maintain system reliability shall be flexible Teflon hose with a braided stainless steel jacketed fittings. They use standard SAE or JIC brass or steel, flanged, swivel-type fittings. Flexible hoses shall be as short as practicable and individually supported. They shall not touch one another or any part of the bus except for the supporting grommets. Flexible lines shall be supported at 2ft intervals or less.

Air lines shall be clean before installation and shall be installed to minimize air leaks. All air lines shall be routed to prevent water traps to the extent possible. Grommets or insulated clamps shall protect the air lines at all points where they pass through understructure components.

2.3.10.4 Air Reservoirs

All air reservoirs shall meet the requirements of FMVSS Standard 121 and SAE Standard J10 and shall be equipped with drain plugs and guarded or flush type drain valves. Major structural members shall protect these valves and any automatic moisture ejector valves from road hazards. Reservoirs shall be sloped toward the drain valve. All air reservoirs shall have drain valves that discharge below floor level with lines routed to eliminate the possibility of water traps and/or freezing in the drain line.

2.3.10.5 Air System Dryer

An air dryer shall prevent accumulation of moisture and oil in the air system. The air dryer system shall include a replaceable desiccant bed, electrically heated drain, and activation device. A 2M/3M mechanic shall replace the desiccant in less than 15 minutes.

2.3.11 WHEELS AND TIRES

2.3.11.1 Wheels

All wheels shall be interchangeable and shall be removable without a puller. Wheels shall be compatible with tires in size and load carrying capacity. Front wheels and tires shall be balanced as an assembly per SAE J1986.

Wheels shall be Hub-piloted, mounted Alcoa (or approved equal) aluminum wheels and shall resist rim flange wear. Wheels shall have a low maintenance special finish on both sides. Finish shall be Alcoa Dura-Bright, or approved equal.

2.3.11.2 Tires

Tires shall be suitable for the conditions of transit service and sustained operation at the maximum speed capability of the bus. Load on any tire at GVWR shall not exceed the tire supplier's rating.

The buses shall be equipped with low profile tires, Load range H as appropriate for the bus design. Expected tire sizes are 19.5 inches for 30-foot bus and 22.5 inches for 35-foot and 40-foot buses.

Bus manufacturer shall designate tire size in accordance with FMVSS requirements and manufacturer's recommendations. If the buses must be equipped with low profile standard transit tires, with a specific load range, as appropriate for the bus design, the Proposer must advise with the technical proposal.

Delivery shall include one (1) set of four (4) mounted spare tires and rims supplied with each coach.

2.3.12 BUMPERS

2.3.12.1 Location

Bumpers shall provide impact protection for the front and rear of the bus with the top of the bumper being (26 +/- 2) inches above the ground. Bumper height shall be such that when one bus is parked behind another, a portion of the bumper faces will contact each other.

2.3.12.2 Front Bumper

No part of the bus, including the bumper, shall be damaged as a result of a 5mph impact of the bus at curb weight with a fixed, flat barrier perpendicular to the bus's longitudinal centerline. The bumper shall return to its pre-impact shape within 10 minutes of the impact. The bumper shall protect the bus from damage as a result of 6.5 mph impacts at any point by the common carriage with contoured impact surface defined in Figure 2 of FMVSS 301 loaded to 4,000 lbs. parallel to the longitudinal

centerline of the bus. It shall protect the bus from damage as a result of 5.5mph impacts into the corners at a 30° angle to the longitudinal centerline of the bus. The energy absorption system of the bumper shall be independent of every power system of the bus and will not require service or maintenance in normal operation during the service life of the bus. The bumper may increase the overall bus length specified by no more than 7 inches.

The bumper shall provide mounting provisions for a bike rack.

2.3.12.3 Rear Bumper

No part of the bus, including the bumper, shall be damaged as a result of a 2 mph impact with a fixed, flat barrier perpendicular to the longitudinal centerline of the bus. The bumper shall return to its pre-impact shape within 10 minutes of the impact. When using a yard tug with a smooth, flat plate bumper 2 ft. wide contacting the horizontal centerline of the rear bumper, the bumper shall provide protection at speeds up to 5 mph, over pavement discontinuities up to 1 in. high, and at accelerations up to 2 mph/sec. The rear bumper shall protect the bus, when impacted anywhere along its width by the common carriage with contoured impact surface defined in Figure 2 of FMVSS 301 loaded to 4,000 lbs., at 4 mph parallel to or up to a 30-degree angle to, the longitudinal centerline of the bus. The rear bumper shall be shaped to preclude unauthorized riders standing on the bumper. The bumper shall not require service or maintenance in normal operation during the service life of the bus. The bumper may increase the overall bus length specified by no more than 7 inches.

2.3.12.4 Bumper Material

Bumpers shall be energy absorbing and black in color. Bumper material shall be corrosion-resistant and withstand repeated impacts of the specified loads without sustaining damage. Visible surfaces shall be black. These bumper qualities shall be sustained throughout the service life of the bus.

2.4 Electrical, Electronic, and Data Communication Systems

2.4.1 GENERAL REQUIREMENTS

2.4.1.1 Systems Overview

The Electrical System will consist of the vehicle battery systems and all other equipment that generate, distribute and use battery power throughout the vehicle (e.g., drive system batteries, inverters, motor drives, contactors, high voltage fuses, high voltage switches, wiring, relays, and connectors).

Electronics are those components of the electrical system made up of discrete solid-state devices such as transistors, resistors, capacitors and diodes that are part of individual vehicle systems. Electronics also include the integrated circuits that are part of microprocessors that allow individual vehicle systems to process and store data.

The data communication system consists of the bi-directional communications networks that electronic devices use to share data with other electronic devices and systems. Communication networks are essential to integrating electronic functions, both onboard the vehicle and off.

Data communications systems are divided into three levels to reflect the use of multiple data networks.

- **Drivetrain Level:** Components related to the drivetrain including the Traction Motor, transmission, and anti-lock braking system (ABS), which may include traction control.
- **Information Level:** Components whose primary function is the collection, control or display of data that is not necessary to the safe drivability of the vehicle (i.e., those functions, which when inoperable, will still allow the vehicle to operate). These components typically consist of those required for automatic vehicle location (AVL) systems, destination signs, fare boxes, passenger counters, radio systems, automated voice and signage systems, video surveillance, and similar components.
- **Multiplex Level:** Electrical devices controlled through input/output signals such as discrete, analog, and serial data information (i.e., on/off switch inputs, relay or relay control outputs). Multiplexing is used to control components not typically found on the Drivetrain or Information Levels such as lights, wheelchair lifts, doors, and heating, ventilation, air conditioning (HVAC) systems.

FIGURE 5

Data Communications Systems Levels

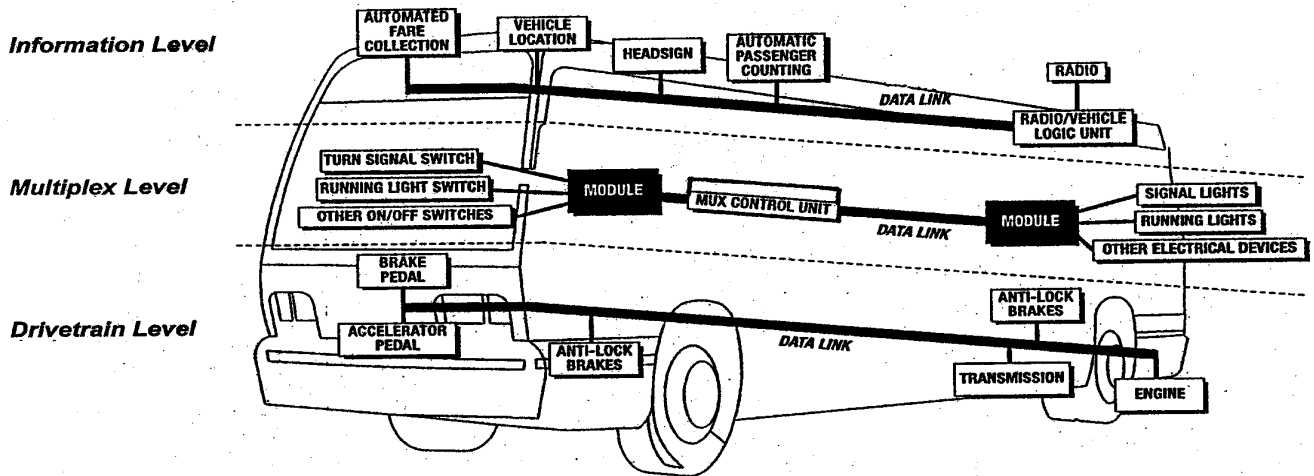

2.4.1.2 Modular Design

Design of the electrical, electronic and data communication systems shall be modular so that each major component, apparatus panel, or wiring bundle is easily separable with standard hand tools or by means of connectors. Each module, except the main body wiring harness, shall be removable and replaceable in less than 1 hour by a 3M mechanic.

Power Plant wiring shall be an independent wiring module. Replacement of the drive system compartment wiring module(s) shall not require pulling wires through any bulkhead or removing any terminals from the wires.

2.4.1.3 Environmental and Mounting Requirements

The electrical system and its electronic components shall be capable of operating in the area of the vehicle in which they will be installed, as recommended in SAE J1455.

Electrical and electronic equipment shall not be located in an environment that will reduce the performance or shorten the life of the component or electrical system when operating within the design operating profile. No vehicle component shall be able to generate or be affected by electromagnetic interference or radio-frequency interference (EMI/RFI) that can disturb the performance of electrical/electronic equipment as defined in SAE J1113 and UNECE Council Directive 95/54 (R10).

The mounting of the hardware shall not be used to provide the sole source ground, and all hardware is isolated from potential EMI/RFI, as referenced in SAE J1113.

All electrical/electronic hardware mounted in the interior of the vehicle shall be inaccessible to passengers and hidden from view unless intended to be viewed. The hardware shall be mounted in such a manner as to protect it from splash or spray. All electrical/electronic hardware mounted on the exterior of the vehicle that is not designed to be installed in an exposed environment shall be mounted in a sealed enclosure.

All electrical/electronic hardware and its mounting complies with the shock and vibration requirements of SAE J1455.

Contractor shall provide recommendations from bus manufacturer and subsystem suppliers regarding methods to prevent damage from voltage spikes generated from welding, jump-starts, shorts, etc. The Contractor will supply a checklist of connectors and connections to be opened when electric welding is performed on the bus.

2.4.2 ELECTRICAL SYSTEM REQUIREMENTS

2.4.2.1 Batteries

2.4.2.1.1 Low-Voltage Batteries

The system shall supply a nominal 12V and/or 24V of direct current (DC). Batteries, except those used for auxiliary power, shall be easily accessible for inspection and service from the outside of the vehicle only.

Group 31 Series deep cycling maintenance free battery units shall be provided with sufficient amperage capacity to continuously power 200% of the expected maximum low-voltage loads. Batteries shall provide sufficient amp-hours to power auxiliary loads for a duration of 2 hours in the event of a failure of the high-voltage battery system or DC/DC converter. Low-voltage batteries shall be capable of starting the coach after sitting idle for a minimum duration of one-week.

Each battery shall have a purchase date no more than one year from date of release for shipment to the customer.

2.4.2.1.2 Battery Cables

The positive and negative battery terminal ends and cables shall be color-coded with red for the primary positive, black for negative, and another color for any intermediate voltage cables. Heat shrink at the terminal ends of the aforementioned colors may be

used on battery cables with black insulation. Battery cables shall be flexible and sufficiently long to reach the batteries with tray in the extended position without stretching or pulling on any connection and shall not lie directly on top of the batteries. Except as interrupted by the master battery switch(s), battery wiring shall be continuous cables with connections secured by bolted terminals; and shall conform to specification requirements of SAE J1127 –Type SGT or SGX and SAE Recommended Practice J541.

2.4.2.1.3 Jump Start

A jump-start connector, red for 24V and blue for 12V, shall be provided in the electric drive train compartment, equipped with dust cap and adequately protected from moisture, dirt and debris.

2.4.2.1.4 Battery Compartments

The battery compartments shall prevent accumulation of snow, ice and debris on top of the batteries and shall be vented and self-draining. It shall be accessible only from the outside of the vehicle. All components within the battery compartments, and the compartments themselves, shall be protected from damage or corrosion from electrolyte and gases emitted from the batteries. The inside surface of the battery compartment's access door shall be electrically insulated, as required, to prevent the battery terminals from shorting on the door if the door is damaged in an accident or if a battery comes loose.

Provide and install 110/120-volt adapter/converter in the low-voltage battery compartment so as to operate all the interior lighting without draining the batteries while the bus is being cleaned. The plug location shall be installed on the dash door panel. The plug shall be stainless steel with stainless steel mounting screws.

2.4.2.1.5 Auxiliary Electronic Power Supply

If required, gel-pack, or any form of encased batteries used for auxiliary power, are allowed to be mounted on the interior of the vehicle if they are contained in an enclosed, non-airtight compartment and accessible only to maintenance personnel. This compartment shall contain a warning label prohibiting the use of lead-acid batteries.

2.4.2.1.6 Master Battery Switch

A single master switch shall be provided near the battery compartment for the disconnecting of all battery positives (12V & 24V) except for safety devices such as fire suppression system and other systems as specified. The location of the master battery switch shall be clearly identified on the exterior access panel, be accessible in less than

10 seconds for de-activation, and prevent corrosion from fumes and battery acid when the batteries are washed off or are in normal service.

Turning the master switch "OFF", shall not damage any component of the electrical system. The master switch shall be capable of carrying and interrupting the total circuit load.

2.4.2.1.7 Low-Voltage Generation and Distribution

The Propulsion System Batteries shall maintain the charge on the low voltage batteries.

The vehicle shall be equipped with a 300-AMP minimum, 24 VDC DC-DC power converter, suitably rated to handle the electrical load requirements. The high output DC amps shall be achieved at the DC-DC power converter's designed maximum output.

Power distribution shall be accomplished by means of conductive bus-bars, terminal strips, or stud-terminal blocks that are sized for the cumulative total current of connected branch circuits and for the physical securement of them. One such arrangement is to exist for each voltage potential level and ground. These points to all equipment requiring dedicated power and ground wiring to the batteries shall be accomplished by using power bus bars consisting of either a solid copper bar or heavy-duty terminal strip. One bus bar for each voltage potential, including ground, shall be located as close, electrically speaking, to the source of the potential (the battery source) as physically practical, based on recommendations of the vehicle manufacturer. Terminal stack-up is not to exceed a quantity of four (4) per each individual screw, post, or stud block. All cabling and wiring associated with an individual circuit will be sized to ensure a voltage drop figure of no more than 5% of the source voltage. This figure is to cover the total loop from source potential to source ground.

2.4.2.1.8 Circuit Protection

All branch circuits shall be protected by circuit breakers or fuses sized to the requirements of the load. The circuit breakers or fuses shall be easily accessible for authorized personnel. Fuses shall be used only where it can be demonstrated that circuit breakers are not practicable. Any manually re-settable circuit breakers shall provide visible indication of open circuits.

Fuses shall be located adjacent to power source, and in a fuse block except as specifically approved by the customer after contract award.

Circuit breakers or fuses shall be sized to a minimum of 15% larger than the total circuit load current. The current rating for the wire used for each circuit must exceed the size of the circuit protection being used.

2.4.2.2 Grounds

The batteries shall be grounded to the vehicle chassis/frame at one location only, as close to the batteries as possible. No more than four (4) ground connections shall be made per ground stud. Electronic equipment requiring an isolated ground to the battery (i.e., electronic ground) shall not be grounded to the chassis.

2.4.2.3 Low Voltage/Low Current Wiring and Terminals

All power and ground shall conform to specification requirements of SAE Recommended Practice J1127, J1128 and J1292 for type GXL and SXL wiring. Double insulation shall be maintained as close to the junction box, electrical compartment or terminals as possible.

Wiring shall be grouped, labeled, and color-coded. Wiring harnesses shall not contain wires of different voltage classes unless all wires within the harness are insulated for the highest voltage present in the harness. Kinking, grounding at multiple points, stretching, and exceeding minimum bend radius shall be prevented.

Strain-relief fittings shall be provided at all points where wiring enters electrical compartments. Grommets or other protective material shall be installed at points where wiring penetrates metal structures outside of electrical enclosures. Wiring supports shall be protective and non-conductive at areas of wire contact and will not be damaged by heat, water, solvents or chafing.

To the extent practicable, wiring shall not be located in environmentally exposed locations under the vehicle. Wiring and electrical equipment necessarily located under the vehicle shall be insulated from water, heat, corrosion and mechanical damage. Where feasible, front-to-rear electrical harnesses shall be installed above the window line of the vehicle.

All wiring harnesses over 5 ft. long and containing at least five wires shall include 10% (minimum one wire) excess wires for spares. This requirement for spare wires does not apply to data links and communication cables. Wiring harness length shall allow end terminals to be replaced twice without pulling, stretching or replacing the wire. Terminals shall be crimped to the wiring according to the connector or manufacturer's recommendations for techniques and tools. All cable connectors shall be locking type, keyed and sealed, unless enclosed in watertight cabinets or the vehicle interior. Pins shall be removable, crimp contact type, of the correct size and rating for the wire being terminated. Unused pin positions are sealed with sealing plugs. Adjacent connectors shall either use different inserts or different insert orientations to prevent incorrect connections.

Terminals shall be crimped, corrosion-resistant and full ring type or interlocking lugs with insulating ferrules. When using pressure type screw terminal strips, only stranded wire shall be used. Insulation clearance shall ensure that wires have a minimum of “visible clearance” and a maximum of two times the conductor diameter or 1/16 inch, whichever is less. When using shielded or coaxial cable, upon stripping of the insulated, the metallic braid shall be free from frayed strands that can penetrate the insulation of the inner wires.

Ultra-sonic and T-splices may be used with 8 AWG or smaller wire. When a T-splice is used, it shall meet these additional requirements:

- It shall include a mechanical clamp.
- The wire shall support no mechanical load in the area of the splice.
- The wire shall be supported to prevent flexing.

All splicing shall be staggered in the harness. Wiring located in the electric motor compartment shall be routed away from high-heat sources or shielded and/or insulated from temperatures exceeding the wiring and connector operating requirements.

The instrument panel and wiring shall be easily accessible for service from the driver’s seat or top of the panel. The instrument panel shall be separately removable and replaceable without damaging the instrument panel or gauges. Wiring shall have sufficient length and routed to permit service without stretching or chafing the wires.

2.4.2.4 Electrical Components

All electrical components, including switches, relays, flashers, and circuit breakers, shall be heavy-duty designs with either a successful history of application to heavy-duty vehicles, or design specifications for an equivalent environment. These components shall be replaceable in less than 5 minutes by a 3M mechanic.

All electric motors shall be either heavy-duty brushless type where practical, or have a constant duty rating of no less than 40,000 hours. All electric motors shall be easily accessible for servicing.

2.4.2.5 Electrical Compartments

All relays, controllers, flashers, circuit breakers, and other electrical components shall be mounted in easily accessible electrical compartments. All compartments exposed to the outside environment shall be corrosion resistant and sealed. The components and circuits in each electrical compartment shall be identified and their location permanently recorded on a drawing attached to the inside of the access panel or door. The drawing shall be protected from oil, grease, fuel, and abrasion.

Junction boxes shall have laminated schematics or the front compartment shall be completely serviceable from the operator's seat, vestibule, or from outside.

2.4.3 GENERAL ELECTRONIC REQUIREMENTS

If an electronic component has an internal real-time clock, it shall provide its own battery backup to monitor time when battery power is disconnected, and/or it may be updated by a network component. If an electronic component has an hour meter, it shall record accumulated service time without relying on battery backup.

The Contractor shall ensure that their electronic equipment is self-protecting in the event of shorts in the cabling, as well as in over-voltage and reverse polarity conditions. If an electronic component is required to interface with other components, it shall not require external pull-up and/or pull-down resistors. Where this is not possible, the use of pull-up or pull-down resistor must be limited as much as possible and if used, must be easily accessible and labeled appropriately.

2.4.3.1 Wiring and Terminals

Kinking, grounding at multiple points, stretching, and reducing the bend radius below the manufacturer's recommended minimum shall not be permitted.

2.4.3.2 Discrete I/O (Inputs/Outputs)

All wiring to I/O devices, either at the harness level or individual wires, shall be labeled, stamped or color-coded in a fashion that allows unique identification at a spacing not exceeding 4 in. Wiring for each I/O device shall be bundled together. If the I/O terminals are the same voltages, then jumpers may be used to connect the common nodes of each I/O terminal.

2.4.3.3 Shielding

All wiring shall be shielded and shall meet the following minimum requirements. A shield shall be generated by connecting to a ground, which is sourced from a power distribution bus bar or chassis. A shield shall be connected at one location only, typically at one end of the cable. However certain standards or special requirements, such as SAE J1939 or RF applications, have separate shielding techniques that shall also be used as applicable.

NOTE: A shield grounded at both ends forms a ground loop, which can cause intermittent control or faults.

When using shielded or coaxial cable, upon stripping of the insulation, the metallic braid shall be free from frayed strands, which can penetrate the insulation of the inner wires. To prevent the introduction of noise, the shield shall not be connected to the common side of a logic circuit.

2.4.3.4 Communications

The data network cabling shall be installed according to the selected protocol requirements. The physical layer of all network communication systems shall not be used for any purpose other than communication between the system components, unless provided for in the network specifications.

Communications networks that use power line carriers (e.g., data modulated on a 24V power line) shall meet the most stringent applicable wiring and terminal specifications.

2.4.3.5 Radio Frequency (RF)

RF components, such as radios, video devices, cameras, global positioning systems (GPS), etc., shall use coaxial cable to carry the signal. All RF systems require special design consideration for losses along the cable. Connectors shall be minimized, since each connector and crimp have a loss that will attribute to attenuation of the signal. Cabling should allow for the removal of antennas or attached electronics without removing the installed cable between them. If this cannot be done, then a conduit of sufficient size shall be provided for ease of attachment of antenna and cable assembly. The corresponding component vendors shall be consulted for proper application of equipment, including installation of cables.

2.4.3.6 Audio

Cabling used for microphone level and line level signals shall be 22 AWG minimum with shielded twisted pair. Cabling used for amplifier level signals shall be 18 AWG minimum.

2.4.4 DATA COMMUNICATION SYSTEM REQUIREMENTS

2.4.4.1 General Requirements

All data communication networks shall be in accordance with a nationally recognized interface standard such as those published by SAE, IEEE, or ISO.

Any electronic vehicle components used on a network shall be conformance tested to the corresponding network standard.

The vehicle shall be designed with a fully integrated diagnostic system where the master vehicle controller monitors and records the fault status from all systems on the main PCAN network as well as fault status from the multiplex devices. This shall include subsystems such as the powertrain controller, cooling system, ABS system, HVAC system, battery management system and other power devices. This diagnostic system shall also include the detection of loss of communication of all individual devices on the PCAN and MCAN network.

All faults shall be recorded, time stamped, odometer stamped and assigned a priority level based on the severity of the fault. A diagnostic tool shall also serve as a troubleshooting guide to aid in quick resolution of individual faults.

The following information shall be displayed when using the instrument cluster and diagnostic tool:

- a) Fault status (active or previously recorded and inactive)
- b) Identifying number (SPN and FMI according to J1939)
- c) General description of part faulted (SPN description)
- d) Type of fault (FMI description; i.e. value to high, to low, data erratic, loss of communication)
- e) Multiplexer input or output pin where fault was detected or system where fault was originated
- f) Time, date and odometer reading at time of fault

A vehicle data logger must be provided to monitor J1939 communications system. It shall provide:

- a) Continuous monitoring and recording of the PCAN J1939 data bus.
- b) Software that can generate structured reports using the gathered data.
- c) Software to create tools for incident definition, data import/export, analysis and presentation.
- d) Software for recording of user selected J1939 fault codes.

2.4.4.2 Bus Energy Monitoring

The vehicle's onboard systems shall store data records representing the propulsion system activity at 1 second intervals, such as duty cycle information (time, location, altitude, speed), voltage and current input and output for major electrical components (ESS, power converters, HVAC, etc.), traction motor input voltage and current, traction motor output torque and rotational speed, system health, BMS information, and faults.

The system shall be capable of profiling DC and AC energy consumption, tractive energy, regenerative braking and hotel loads, such as, lighting, HVAC and support system loads, such as steering, fans, cooling, air, system faults, etc. Data shall be uploaded to a cloud-based central storage system in real time or upon returning to the depot. Data shall be viewable in the cloud-based system, and exportable in .csv format. The on-board system shall be capable of storing one week of all data and reports in memory that can be downloaded from the bus using a standard laptop computer.

2.4.4.3 Multiplexing Requirements

The primary purpose of the multiplexing system is control of components necessary to operate the vehicle. This is accomplished by processing information from input devices and controlling output devices through the use of an internal logic program.

Versatility and future expansion shall be provided for by an expandable system architecture. The multiplex system shall be capable of accepting new inputs and outputs through the addition of new modules and/or the utilization of existing spare inputs and outputs. All like components in the multiplex system shall be modular and interchangeable with self-diagnostic capabilities. The modules shall be easily accessible for troubleshooting electrical failures and performing system maintenance. Multiplex input/output modules shall use solid-state devices to provide extended service life and individual circuit protection.

Ten percent of the total number of inputs and outputs, or at least one each at each zone location shall be designated as spares.

2.4.4.3.1 System Configuration

Multiplexing must be centralized. A centralized system shall consist of several modules connected to form a control network. The system shall be managed by a master vehicle controller. It provides the configurability and the control required to integrate all systems on the bus. The vehicle shall be equipped with a I/O Controls DINEX G3 multiplexing system or approved equal.

The proposed multiplex network system shall provide the Intelligent Key™ feature.

Control system shall be equipped to accommodate a wireless diagnostic system if selected by Procuring Agency.

2.4.4.3.2 I/O Signals

The input/output for the multiplex system shall contain four types of electrical signals: discrete, analog, serial data, and modulating.

Discrete signals shall reflect the on/off status of switches, levers, limit switches, lights, etc. Analog signals reflect numerical data as represented by a voltage signal (for example 0–5V) or resistance signal (for example NTC thermistor). Both types of analog signals shall represent the status of variable devices such as rheostats, op-amps, potentiometers, temperature probes, etc.

2.4.4.4 Drivetrain Level

2.4.4.4.1 General Requirements

Drivetrain components, consisting of the traction motor inverters, regenerative braking system, anti-lock braking system, transmission (if used), and all other related components, shall be integrated and communicate fully with respect to vehicle operation with data using SAE Recommended Communications Protocols such as J1939. Drivetrain components shall be powered by a supply voltage to ensure data communication among components exists when the vehicle ignition is switched to the “on” position.

See fire protection requirements for wiring passing through the motor compartment bulkhead.

2.4.4.4.2 Diagnostics, Fault Detection and Data Access

Drivetrain performance, maintenance and diagnostic data, and other electronic messages shall be formatted and transmitted on the communications network.

The drivetrain level shall have the ability to record abnormal events in memory and provide diagnostic codes and other information to service personnel. These codes shall be available from the driver’s digital display or on the diagnostic tool. The communication ports shall be located at the front and rear interior of the vehicle.

2.4.4.4.3 Programmability (Software)

The drivetrain level components shall be programmable by Procuring Agency with limitations as specified by the sub system Supplier.

2.4.4.5 Multiplex Level

2.4.4.5.1 Data Access

At a minimum, information shall be made available via communication ports on the multiplex system at the front and rear interior of the vehicle. The location of the communication ports shall be easily accessible.

2.4.4.5.2 Diagnostics and Fault Detection

The multiplex system shall have a proven method of determining its status (system health and input/output status) and detecting either active (Online) or inactive (Offline) faults through the use of on-board visual/audible indicators.

In addition to the indicators, the system shall employ an advanced diagnostic and fault detection system, which shall be accessible via the diagnostic tool. The diagnostic tool shall have the ability to check logic function.

2.4.4.5.3 Programmability (Software)

The multiplex system shall have security provisions to protect its software from unwanted changes. This shall be achieved through any or all of the following procedures:

- a) password protection,
- b) limited distribution of the configuration software,
- c) limited access to the programming tools required to change the software,
- d) hardware protection that prevents undesired changes to the software.

Provisions for programming the multiplex system shall be possible through the diagnostic tool. The multiplex system shall have proper revision control to ensure that the hardware and software is identical on each vehicle equipped with the system. Revision control shall be provided by all of the following:

- a) hardware component identification where labels are included on all multiplex hardware to identify components,
- b) hardware series identification where all multiplex hardware displays the current hardware serial number and firmware revision employed by the module,
- c) software revision identification where all copies of the software in service displays the most recent revision number, and a method of determining which version of the software is currently in use in the multiplex system.

2.4.4.6 Electronic Noise Control

Electrical and electronic sub systems and components on all buses shall not emit electro-magnetic radiation that will interfere with on-board systems, components or equipment, telephone service, radio or TV reception, or violate regulations of the Federal Communications Commission.

Electrical and electronic sub systems on the buses shall not be affected by external sources of RFI/EMI. This includes, but is not limited to, radio and TV transmission,

portable electronic devices including computers in the vicinity of or onboard the buses, AC or DC power lines and RFI/EMI emissions from other vehicles.

2.4.5 COMMUNICATIONS ACCESSORIES

2.4.5.1 Mobile Radio System

A compartment shall be provided to accommodate a communication system enabling the driver to contact the dispatcher. It shall be located within 8 feet of the driver's seat and shall be connected to the driver's area by waterproof conduit. The compartment shall include a clear space 12 inches high, 18 inches wide, and 24 inches deep for location of the radio.

Procuring Agency shall have the option to add mounts and/or radio to the dash. A 20-amp fuse, 12-volt battery supply; 10-amp fuse, 12-volt ignition supply, and negative ground circuits shall be provided when dash mounts and/or radio are chosen.

Communication system shall be accessible from either inside or outside of the coach and shall be splash proof when the service door is secured. The radio compartment shall be supplied with a 30 amp, 12-volt, DC-protected service with positive and negative leads. A location convenient to the driver shall be provided for the radio control head, speaker, and handset. Provisions for attaching an antenna to the roof and routing an antenna lead to the radio compartment shall include a conduit with an interior diameter of $\frac{3}{4}$ inch and a pull wire. The antenna mounting and lead termination shall be accessible from the coach interior.

Unless specified otherwise, Procuring Agency will install their own radio system after delivery. The radio equipment is not part of the contract and the contractor shall not include radio equipment or the installation of a radio in this contract.

2.4.5.2 Public Address System

The contractor shall provide and install a public address system that enables the operator to address the passengers either inside or outside the bus. A total of eight (8) interior flush-mounted speakers shall broadcast in a clear tone, so that announcements are clearly perceived from all seat positions at approximately the same volume level. One (1) exterior speaker shall be provided outside the entrance door so that announcements can be clearly heard by passengers standing near the door. An operator-controlled switch shall select inside or outside announcements. The microphone shall be hands free operation.

Public address system shall be in compliance with the requirements of 49 CFR 38.35.

2.4.6 SECURITY CAMERA SYSTEM

The security camera system shall be a Seon Explorer TH8 Channel DVR with 2 TB HDD or approved equal, consisting of a minimum of 12 analog video and audio inputs, H.264 compression, and integrated locking enclosure, provided to monitor and record events onboard the buses at all times when the buses are powered on.

2.4.6.1 Recording Unit

The recording unit shall continually digitize video from all on-board cameras, provide compression of the video, and store the video on a removable hard drive. The recording unit shall have an internal clock, used to time and date stamp recorded video. The unit shall be designed for a mobile application and shall be protected against EMI and RFI. Each of the video inputs shall accept color, Nation Television System Committee (NTSC) format.

2.4.6.2 Resolution

Images shall be digitized with at least 720x480 pixel resolution.

2.4.6.3 Frame Rate

Video from each input shall be capable of recording at a rate of up to 30 frames per second (FPS) per camera, simultaneously.

2.4.6.4 Recording Capacity

Video compression shall be utilized such that the recorder shall have capacity to record images from all onboard cameras for at least seventy-two hours before overwriting the recorded information. This capacity shall include time and date stamp of the video. The oldest video stored shall be automatically overwritten so that video is recorded on a continuous basis.

2.4.6.5 Digital Format

The video storage format shall include secure, encrypted encoding such that alteration to the images can be detected. The system shall provide provisions to expand the recording media and provide the capability to upgrade to the latest digital media technology.

2.4.6.6 Diagnostics

The system shall be equipped with a fault log file which shall store fault and system information. The information to be stored shall include but is not limited to: ignition on/off

times, start and stop events, camera failures, and hard drive errors. All faults shall be time and date stamped and accessible via a laptop through a diagnostic port. Provisions shall be provided for wireless communications between a laptop, recording device, and fault log.

2.4.6.7 Removable Hard Drive

The hard drive used for video storage shall be a hot swappable, rugged, dual drive designed for a transit bus environment. It shall be housed in a ruggedized, locking enclosure which is integral to the recording unit. The hard drive shall be designed for rapid removal and installation, without the use of special tools and requiring no more than fifteen seconds. Connections shall provide positive feedback of correct insertion. When a hard drive is inserted, visual indication shall be provided on the front panel of the unit that the hard drive is inserted correctly and that it is functioning correctly. The hard drive shall automatically connect and synchronize to the onboard system. No additional formatting shall be required. A common key shall be used for all hard drives. One key will be provided with each bus.

2.4.6.8 Operating System and Processor

The recorder operating system shall be the most current and stable version of the operating system. The operating system shall detect a hang-up and shall automatically restart. Video that was previously recorded shall not be lost due to a processor restart. The processor shall be a commercially available Linux-based processor, designed for rugged application.

2.4.6.9 Decals

In accordance with State and Federal laws, interior and exterior decals shall be provided notifying passengers that this bus is equipped with a video security system. Decal location and text shall be approved by Procuring Agency.

2.4.6.10 Cameras

Eleven (11) Day/Night cameras shall be provided in the locations outlined here. Cameras shall be NTSC compatible with 1/3 inch or larger charge-coupled device (CCD) imager and fixed-length lens. Camera and lens combinations shall be selected to maximize image quality through the range of lighting conditions on buses in operation. Cameras shall accommodate normal and wide-angle lenses. Cameras shall meet or exceed the following specifications:

- a) Minimum resolution shall be 720x480 pixels.
- b) Scanning shall be interlaced.
- c) Internal and external sync.
- d) Minimum illumination shall be less than or equal to 0.95 lux.

- e) Interior cameras shall have built-in microphone capable of recording audio

The system shall include one (1) IP camera with 720p / 1080p / 3MP (selectable) progressive scan resolution. Camera shall be located in the front of the bus facing forward through the windshield.

2.4.6.11 Lens

Camera lenses shall have an automatically adjusting iris. Focal length shall be selected to maximize viewable area for each camera location.

2.4.6.12 Enclosure

Each camera shall be provided within an enclosure suitable for the approved mounting location. Enclosures shall be vandal resistant and fastened with tamperproof screws. Camera enclosures shall be in neutral colors, suitable to the Procuring Agency's color scheme. Enclosure sizes shall be minimized. Enclosure shape shall be suitable for the mounting location, so as not to present sharp edges or corners.

2.4.6.13 Camera Location

Cameras on Transit buses shall be located to provide surveillance of the following areas:

- 1) Interior of the bus looking rearward from front vestibule.
- 2) Mounted beneath the front destination sign bulkhead, looking through windshield.
- 3) Exterior of bus, mounted above front door, looking rearward along curb side of bus.
- 4) Interior of bus looking forward from rear, ceiling-mounted at centerline of bus.
- 5) Passengers entering bus and fare box interaction, mounted above driver control area.
- 6) Exterior of street side of bus looking rearward, mounted above driver's window.
- 7) Interior of bus looking at rear balcony area, ceiling-mounted at centerline of bus.
- 8) Passengers exiting bus and fare box interaction, mounted on curb side of front vestibule.
- 9) Exterior of bus, mounted above rearmost passenger window, looking forward along curb side of bus.
- 10) Exterior of bus, mounted above rearmost passenger window, looking forward along street side of bus.

Contractor shall submit drawings detailing the proposed camera mounting locations for approval by Purchasing Agency.

Procuring Agency has option to add or delete any number of cameras and locations from base configuration.

2.4.6.14 Security Video Playback

Playback shall be made possible through the use of a laptop computer to download fault logs and the video/audio files stored on the system's hard drive. The unit shall also enable recordings of selected portions to a DVD and play back those portions for viewing.

Procuring Agency shall have the option to include, with the purchase, a laptop computer equipped with the necessary software, hardware, and cabling provisions for communication with security system.

2.4.6.15 Wiring Harness Conduit

All wiring for the Security Camera System shall be installed in appropriately sized conduit. Harness and conduit installation shall be approved by the Procuring Agency.

2.4.6.16 Wireless Download Capability

Security system shall include all necessary wireless LAN bus hardware to facilitate upload/download data to/from video system. The DVR shall support industrial Wi-Fi networking with Smart-Reach Mobile (wireless bridge) or equivalent with roaming capability. Consumer grade wireless bridge is not acceptable.

2.5 Vehicle Charging Requirements

2.5.1 GENERAL REQUIREMENTS

The vehicle must be immobilized during all charging operations. Upon successful engagement of the charging interface, the bus shall be interlocked such that propulsion is rendered non-tractive and the brakes applied.

Charging port shall be located at the rear of the bus, curb side. Charging port shall not be energized unless mated to EVSE plug.

Charging circuits shall be isolated from the vehicle chassis such that ground current from the grounded chassis does not exceed 5 mA.

Vehicle loads shall be minimized while connected to the EVSE. Battery warmers and ancillary non-essential equipment shall operate for the minimum times and at minimum levels to preserve performance and ensure safety. Contractor shall list and provide estimated kW and hourly kWh of all ancillary loads that will operate while connected to the EVSE.

If the bus can accomplish depot charging from 20% SOC to 95% SOC in less than 4 hours only with the use of proprietary EVSE, the proprietary EVSE and control systems shall conform to the requirements here, and proposal shall include all details specified.

If the bus is able to charge from 20% SOC to 95% SOC in less than 6 hours with non-proprietary EVSE that use either SAE J1772 CCS Type 1 standard charging protocol or SAE J3068, proposal need not include EVSE information.

If proprietary EVSE is required for the bus to charge at full power, proposal shall include pricing for all required equipment to simultaneously charge all buses, including delivery as well as a description and/or design of the EVSE, showing dimensions and required free space. Port-sharing between buses will not be considered.

If proprietary EVSE is required as per above, Procuring Agency shall have the option of purchasing additional EVSE, and bidder shall provide the unit cost for additional EVSE.

2.5.2 PROPRIETARY CHARGING INFRASTRUCTURE

Proposals which require proprietary charging infrastructure shall include a complete description of the charging systems (including anticipated AC energy consumption for

buses operating on the specified operating profile, power factor, efficiency, total harmonic distortion, and harmonic spectrum). These parameters shall be defined over the entire charge profile that incorporates a complete charge from 20% SOC to 100% SOC.

2.5.2.1 Charging Infrastructure General Information

These general requirements apply to all EVSE to be delivered under the Contract. The Contractor shall provide EVSE and the control and data system needed to recharge the bus ESS.

Contractor shall provide EVSE to allow for simultaneous charging of all buses. EVSE must be vandal-resistant and weatherproof.

Procuring Agency will coordinate with engineering contractors as necessary to complete equipment installation at Procuring Agency's facility. Contractor shall provide close coordination with Procuring Agency and its engineering contractors during site design and installation of EVSE. The Contractor shall be responsible for equipment start-up and testing to ensure that the EVSE meets all stated specifications and functionality prior to site acceptance.

Delivery and configuration of the EVSE so that it is made fully functional upon delivery of buses shall be considered part of this contract.

2.5.2.2 Charging Infrastructure Requirements

The EVSE shall be capable of delivering the optimal battery charge profile as specified by the battery manufacturer and charging the installed traction battery to a fully charged state from the minimum recommended state of charge (SOC) including necessary cool-down time as specified by the battery manufacturer.

The EVSE shall be powered by a 480-volt, 3-phase, 60-Hz electrical supply.

EVSE shall not produce harmonic distortion in excess of 5% THD.

EVSE shall meet or exceed Energy Star key product criteria as outlined at:
https://www.energystar.gov/products/evse_key_product_criteria

2.5.2.2.1 Data Requirements

- Measures and displays kWh consumed and real time AC load in KW within 1% accuracy;
- Is capable of RS-485 communications; and

- Records kWh and kVARh delivered, kWh and kVARh received Stores data in 15-minute intervals for up to 72 days or 5-minute intervals for up to 24 days. Maintains interval data storage in a first-in, first-out format.

Contractor may vary the capacity of the EVSE to allow for overnight charging and battery conditioning with a maximum charge time of six hours to reach 95% SOC Buses shall be charged to Maximum Standard Operating SOC at a rate that maximizes life of the batteries.

2.5.2.2.2 Control Requirements

EVSE shall be configured to automatically initiate charging if properly connected when so signaled by an external timing circuit or control input. The EVSE shall be configured to automatically terminate the connection in the event of hazardous or anomalous conditions.

The EVSE shall be configured to automatically restart charging after unintended interruption of a charging episode due to interruption or temporary degradation of electrical service. Provision shall be made to stagger the resumption of charging among vehicles to reduce spikes in current. The EVSE shall be configured to interface with on-board battery management and interlock systems.

2.5.2.2.3 EVSE Cable and Plug

Conductive cabling connecting depot chargers to the bus shall be a maximum of fifteen feet in length. The connectors shall of simple design and heavy-duty construction. Plug shall not be energized except when mated to vehicle.

2.5.2.3 Operating Environment

EVSE shall be capable of operating continuously without performance or safety degradations in environmental conditions typically found at the Procuring Agency's location. For the purposes of these Specifications such environmental conditions shall mean:

- Storage temperature when not in service: -40°F to +120°F
- Ambient service temperature: -20°F to +95°F
- Maximum service altitude: 1000m above sea level @ 100°F
- Relative humidity range: 5% to 95%, no condensation allowed.

2.5.3 MANAGEMENT, CONTROL AND DATA SYSTEMS

Two (2) data systems shall be provided by the Contractor:

- 1) **High Level Data System:** located in the cloud or at the central depot facility that serves as the data collection and control hub for all EVSE. The high-level data system shall be in communication with the individual EVSE.
- 2) **EVSE Data System:** located at each of the EVSE

All data system communications and license fees shall be pre-paid for ten years and included in the total price for Charging Infrastructure.

Information level systems that require vehicle information for their operations or provide information shall adhere to J1939 data standard.

2.5.3.1 High-Level Data System

The high-level system shall collect data from each component within the system and provide summary reports, such as utility cost, energy consumption, charging profiles, health checks, alarms, etc. The high-level controller shall also be the point of transferring instruction to the EVSE. The proposer shall provide a complete list of data elements reportable from EVSE and connected vehicles, respectively. The high-level system shall be capable of monitoring and limiting total charging system demand based on time of day and day of week at minimum intervals not greater than 15-minutes, configurable by procuring agency.

Proposals should include screenshots of the user interface for the High-Level System.

Contractor shall commission the high-level system when commissioning EVSE. High-level system commissioning shall include assistance with programming charging schedules and provision of up to three sets of login credentials as requested by Procuring Agency.

2.5.3.2 EVSE Data System

The EVSE level system shall be the control point for individual charging ports and provide vehicle- specific energy information including energy consumption by time of day and incident monitoring. The system shall manage and store records on each charge event, including, but not limited to bus ID, charger status, faults, beginning state of charge (SOC), ending SOC, AC energy consumption, max power, etc. The system shall be in communication with the high-level site controller in real time.

Procuring Agency shall have the ability to start and stop charging based on a signal from an outside source such as through Ethernet, Wi-Fi, or another communication protocol, or via the High-Level System.

2.5.4 TWO-WAY POWER FLOW (OPTIONAL)

If two-way power flow from vehicle batteries requires any additional EVSE equipment and/or cost, bidder shall provide details on equipment and pricing required to enable two-way-power flow.

2.6 Quality Assurance Provisions

2.6.1 CONTRACTOR'S IN-PLANT QUALITY ASSURANCE REQUIREMENTS

2.6.1.1 Quality Assurance Organization

The Contractor shall establish and maintain an effective in-plant, quality assurance organization. It shall be a specifically defined organization and should be directly responsible to the Contractor's top management.

2.6.1.1.1 Control

The quality assurance organization shall exercise quality control over all phases of production from initiation of design through manufacture and preparation for delivery. The organization shall also control the quality of supplied articles.

2.6.1.1.2 Authority and Responsibility

The quality assurance organization shall have the authority and responsibility for reliability, quality control, inspection planning, establishment of the quality control system, and acceptance/rejection of materials and manufactured articles in the production of the transit coaches.

2.6.1.2 Quality Assurance Organization Functions

The quality assurance organization shall include the following minimum functions.

2.6.1.2.1 Work Instructions

The quality assurance organization shall verify inspection operation instructions to ascertain that the manufactured product meets all prescribed requirements.

2.6.1.2.2 Records Maintenance

The quality assurance organization shall maintain and use records and data essential to the effective operation of its program. These records and data shall be available for review by the Resident Inspectors. Inspection and test records for this procurement shall be available for a minimum of three (3) years after inspections and tests are completed.

2.6.1.2.3 Corrective Action

The quality assurance organization shall detect and promptly assure correction of any conditions that may result in the production of a defective transit coach. These

conditions may occur in designs, purchases, manufacture, tests, or operations that culminate in defective supplies, services, facilities, technical data, or standards.

2.6.1.3 Standards and Facilities

The following standards and facilities shall be basic in the quality assurance process.

2.6.1.3.1 Configuration Control

The Contractor shall maintain drawings, assembly procedures, and other documentation that completely describe a qualified coach that meets all of the options and special requirements of this procurement. The quality assurance organization shall verify that each transit coach is manufactured in accordance with these controlled drawings, procedures, and documentation.

2.6.1.3.2 Measuring and Testing Facilities

The Contractor shall provide and maintain the necessary gauges and other measuring and testing devices for use by the quality assurance organization to verify that the coaches conform to all specification requirements. These devices shall be calibrated at established periods against certified measurement standards that have known valid relationships to national standards.

2.6.1.3.3 Production Tooling as Media of Inspection

When production jigs, fixtures, tooling masters, templates, patterns, and other devices are used as media of inspection, they shall be proved for accuracy at formally established intervals and adjusted, replaced, or repaired as required to maintain quality.

2.6.1.3.4 Equipment Use by Resident Inspectors

The Contractor's gauges and other measuring and testing devices shall be made available for use by the Resident Inspectors to verify that the coaches conform to all specification requirements. If necessary, the Contractor's personnel shall be made available to operate the devices and to verify their condition and accuracy.

2.6.1.4 Control of Purchases

The Contractor shall maintain quality control of purchases.

2.6.1.4.1 Supplier Control

The Contractor shall require that each supplier maintains a quality control program for the services and supplies that it provides. The Contractor's quality assurance organization shall inspect and test materials provided by suppliers for conformance to

specification requirements. Materials that have been inspected, tested, and approved shall be identified as acceptable to the point of use in the manufacturing or assembly processes. Controls shall be established to prevent inadvertent use of nonconforming materials.

2.6.1.4.2 Purchasing Data

The Contractor shall verify that all applicable specification requirements are properly included or referenced in purchase orders of articles to be used on transit coaches.

2.6.1.5 Manufacturing Control

The Contractor shall ensure that all basic production operations, as well as all other processing and fabricating, are performed under controlled conditions. Establishment of these controlled conditions shall be based on the documented work instructions, adequate production equipment, and special working environments if necessary.

2.6.1.5.1 Completed Items

A system for final inspection and test of completed transit coaches shall be provided by the quality assurance organization. It shall measure the overall quality of each completed coach.

2.6.1.5.2 Nonconforming Materials

The quality assurance organization shall monitor the Contractor's system for controlling nonconforming materials. The system shall include procedures for identification, segregation, and disposition.

2.6.1.5.3 Statistical Techniques

Statistical analysis, tests, and other quality control procedures may be used when appropriate in the quality assurance processes.

2.6.1.5.4 Inspection Status

A system shall be maintained by the quality assurance organization for identifying the inspection status of components and completed transit coaches. Identification may include cards, tags, or other normal quality control devices.

2.6.1.6 Inspection System

The quality assurance organization shall establish, maintain, and periodically audit a fully-documented inspection system. The system shall prescribe inspection and test of materials, work in process, and completed articles. As a minimum, it shall include the

following controls.

2.6.1.6.1 Inspection Personnel

Sufficiently-trained inspectors shall be used to ensure that all materials, components, and assemblies are inspected for conformance with the qualified coach design.

2.6.1.6.2 Inspection Records

Acceptance, rework, or rejection identification shall be attached to inspected articles. Articles that have been accepted as a result of approved materials review actions shall be identified. Articles that have been reworked to specified drawing configurations shall not require special identification. Articles rejected as unsuitable or scrap shall be plainly marked and controlled to prevent installation on the coach. Articles that become obsolete as a result of engineering changes or other actions shall be controlled to prevent unauthorized assembly or installation. Unusable articles shall be isolated and then scrapped.

Discrepancies noted by the Contractor or Resident Inspector during assembly shall be entered by the inspection personnel on a record that accompanies the major component, subassembly, assembly, or coach from start of assembly through final inspection. Actions shall be taken to correct discrepancies or deficiencies in the manufacturing processes, procedures, or other conditions that cause articles to be in nonconformity with the requirements of the contract specifications. The inspection personnel shall verify the corrective actions and mark the discrepancy record. If discrepancies cannot be corrected by replacing the nonconforming materials, the Procuring Agency shall approve the modification, repair, or method of correction to the extent that the contract specifications are affected.

2.6.1.6.3 Quality Assurance Audits

The quality assurance organization shall establish and maintain a quality control audit program. Records of this program shall be subject to review by Procuring Agency.

2.6.1.7 Inspections

2.6.1.7.1 Inspection Stations

Inspection stations shall be at the best locations to provide for the work content and characteristics to be inspected. Stations shall provide the facilities and equipment to inspect structural, electrical, hydraulic, and other components and assemblies for compliance with the design requirements.

Stations shall also be at the best locations to inspect or test characteristics before they are concealed by subsequent fabrication or assembly operations. These locations shall

minimally include underbody structure completion, body framing completion, body prior to paint preparation, water test before interior trim and insulation installation, electric drive train installation completion, underbody dress-up and completion, coach prior to final paint touchup, coach prior to road test, and coach final road test completion.

2.6.1.7.2 Resident Inspector

Procuring Agency maintains the right to be represented at the Contractor's plant by Resident Inspectors and/or Procuring Agency personnel. They shall monitor, in the Contractor's plant, the manufacture of transit coaches built under the procurement. The Resident Inspectors shall be authorized to approve the pre-delivery acceptance tests and release the coach for delivery. The presence of these resident inspectors in the plant shall not relieve the Contractor of its responsibility to meet all of the requirements of this procurement. Upon request to the quality assurance supervisors, the Resident Inspectors shall have access to the Contractor's quality assurance files related to this procurement. These files shall include drawings, assembly procedures, material standards, parts list, inspection processing and reports, and records of defects.

Prior to the beginning of the coach manufacture and continuing throughout the scheduled production, the Contractor shall assist the Resident Inspector in verifying the Buy America domestic content requirement as specified in 49 CFR Part 661 and 49 USC Part 5323(j), as amended by Section 3011 of the FAST Act. Per the FAST ACT, domestic content shall be 65% for FFY2018 and FFY2019, and 70% for FFY2020 and after. At minimum, the Resident Inspector shall:

- a) Review actual component content to ensure that the coach meets the Buy America domestic content requirement for the year of manufacture; and,
- b) Check that the final assembly location is in the United States and the manufacturer's final assembly activities meet the requirements as outlined in the FTA's Pre-Award Buy America Certification, and as approved by Procuring Agency prior to award.
- c) The Resident Inspector must verify that the actual manufacturing processes are consistent with the information provided by the manufacturer and approved by Procuring Agency.

The Contractor shall provide office space for the resident inspectors in close proximity to the final assembly area. This office space shall be equipped with desks, outside and inter-plant telephones, file cabinet, chairs, and clothing lockers sufficient to accommodate the resident staff.

2.6.2 ACCEPTANCE TESTS

2.6.2.1 Responsibility

Fully documented tests shall be conducted on each production coach following manufacture to determine its acceptance to Procuring Agency. These acceptance tests shall include pre-delivery inspections and testing by the Contractor and inspections and testing by Procuring Agency after the coaches have been delivered.

2.6.2.2 Pre-Delivery Tests

The Contractor shall conduct acceptance tests at its plant on each coach following completion of manufacture and before delivery to Procuring Agency. These pre-delivery tests shall include visual and measured inspections, as well as testing the total coach operation. Comprehensive testing of vehicle charging systems shall be performed as well, including interactions with Electric Vehicle Supply Equipment (EVSE), charging profile, and energy management during vehicle charge. The tests shall be conducted and documented in accordance with written test plans, approved by Procuring Agency. Additional tests may be conducted at the Contractor's discretion to ensure that the completed coaches have attained the desired quality and have met the requirements in these technical specifications.

The pre-delivery tests shall be scheduled and conducted with sufficient notice so that they may be witnessed by the Resident Inspectors, who may accept or reject the results of the tests. The results of pre-delivery tests, and any other tests, shall be filed with the assembly inspection records for each coach. The under-floor equipment shall be available for inspection by the resident inspectors, using a pit or coach hoist provided by the Contractor. A hoist, scaffold, or elevated platform shall be provided by the Contractor to easily and safely inspect coach roofs. Delivery of each coach shall require written authorization of the Resident Inspector. Authorization forms for the release of each coach for delivery shall be provided by the Contractor. An executed copy of the authorization shall accompany the delivery of each coach.

2.6.2.2.1 Inspection – Visual and Measured

Visual and measured inspections shall be conducted with the coach in a static condition. The purpose of the inspection testing is to verify overall dimensional and weight requirements, to verify that required components are included and are ready for operation, and to verify that components and subsystems that are designed to operate with the coach in a static condition function as designed.

2.6.2.2.2 Total Coach Operation

Total coach operation shall be evaluated during road tests. The purpose of the road test is to observe and verify the operation of the coach as a system and to verify the

functional operation of the subsystems that can be operated only while the coach is in motion.

Each coach shall be driven for a minimum of fifteen (15) miles during the road tests. Observed defects shall be recorded on the test forms. The coach shall be retested when defects are corrected and adjustments are made. This process shall continue until defects or required adjustments are no longer detected. Results shall be pass/fail for these coach operation tests.

2.6.2.3 Post-Delivery Inspection

2.6.2.3.1 Visual Inspection

The post-delivery inspection is similar to the inspection at the Contractor's plant and shall be conducted with the coach in a static condition. Any visual delivery damage shall be identified and recorded during the visual inspection of each coach.

2.6.2.3.2 Coach Operation

Road tests will be used for total coach operation similar to those conducted at the Contractor's plant. In addition, Procuring Agency may elect to perform chassis dynamometer tests. Operational deficiencies of each coach shall be identified and recorded.

2.7 Warranty Provisions

2.7.1 VEHICLE WARRANTY REQUIREMENTS

Warranties in this document are in addition to any statutory remedies or warranties imposed on the Contractor. Consistent with this requirement, the Contractor warrants and guarantees to Procuring Agency each complete coach, and specific subsystems and components as follows. Warranties specified herein shall not be prorated with the exception of extended or superior warranties that are passed on to Procuring Agency. The Contractor shall pass on to Procuring Agency any warranty, offered by a component supplier, that is superior to that required herein. All major subsystem/component suppliers' warranties, as outlined below, must be purchased from the supplier by the contractor.

During the respective period of the warranty, all vehicle parts or material caused to be damaged as a result of a failure, malfunction, defect in design, material, or workmanship in other parts or material, shall be repaired or replaced at the expense of the Contractor.

Complete warranty information, including term and source, must be provided with the proposal.

2.7.1.1 Complete Coach

The complete coach including propulsion system, components, major subsystems, and body and chassis structure, are warranted to be free from defects and related defects for one (1) year or 50,000 miles, whichever comes first, beginning on the date of acceptance or conditional acceptance of each coach. The warranty is based on regular operation of the bus under the operating condition prevailing in Procuring Agency's locale.

For the first order of buses and EVSE (if included), the in-service date shall be defined as the date all EVSE (if included) is installed fully functional and the bus is delivered fully operational.

2.7.1.2 Body and Chassis Structure

A copy of the chassis manufacturer's warranty must be submitted with the proposal and include the minimum:

- Body, body structure, and structural elements of the suspension are warranted to be free from defects, related defects, and to maintain structural integrity for three years or 150,000 miles, whichever comes first.

- Primary load-carrying members of the coach structure, including structural elements of the suspension, are warranted against corrosion failure and/or fatigue failure sufficient to cause a Class 1 or Class 2 failure, for a period of twelve (12) years or 500,000 miles, whichever comes first.

2.7.1.3 Electronic and Powertrain Components

All electronic and powertrain components shall be warranted for a minimum of 12 years or 500,000 miles, whichever comes first. Note: this warranty will cover performance of the vehicle overall and cover all potential malfunctions related to vehicle operations such as noise, vibration, operations, and heating systems.

2.7.1.4 High Voltage Battery

High voltage battery will be delivered with a twelve (12) year, 250,000 mile warranty.

2.7.1.4.1 Battery Degradation

The Contractor shall provide a plan for replacing or reconditioning batteries if it has been determined that the batteries have degraded beyond their Warrantable End of Life (WEOL). The Contractor must clearly define WEOL and the method by which battery capacity is measured to determine WEOL. The Contractor must define the capacity to which the entire battery pack is restored such that it will remain above the WEOL for the remainder of the warranty.

Battery WEOL shall not be less than 60% of the usable capacity as measured on or before the date of acceptance of the vehicle by producing agency.

2.7.1.4.2 Battery Disposal

The Contractor shall provide a plan for battery packs and/or cells that are removed from service. The plan may include, but is not limited, recycling, repurposing, etc.

2.7.1.4.3 Battery Cycle and Safety Testing

Proposals shall include complete descriptions of all life-cycle testing procedures used to validate the life of batteries used this application at the proposed charging rates, charge durations, and expected ambient temperatures and operating profiles. Bidders shall include documented results of life cycle testing. Bidders shall include certification of battery life cycle testing by independent testing agency.

Proposals shall include complete descriptions of all safety standards followed in the design and manufacture of the battery system, safety testing procedures used to validate the safety of battery operation in this application, and documented results of safety testing to confirm that standards have been met. Bidders shall include certification of battery safety testing by independent testing agency.

2.7.1.5 Major Subsystems

Major subsystems shall be warranted to be free from defects and related defects, for three (3) years or 150,000 miles, whichever comes first. Major Subsystem items include, but are not limited to:

- a) Air compressor and dryer
- b) Brake system (excluding friction material)
- c) Destination signs
- d) Door systems
- e) Heating, Ventilating, and Air Conditioning (HVAC) system
- f) Power steering pump and motors
- g) Wheelchair ramp system
- h) All Interior & Exterior LEDs

2.7.2 VEHICLE WARRANTY PROVISIONS

2.7.2.1 Extension of Warranty

If, during the warranty period, repairs or modifications on any coach, made necessary by defective design, materials, or workmanship are not completed due to lack of material or inability to provide the proper repair for 30 calendar days, the applicable warranty period shall be extended by the number of days equal to the delay period.

2.7.2.2 Voiding of Warranty

The warranties shall not apply to the failure of any part or component of the coach that directly results from misuse, negligence, accident, or that has been repaired or altered in any way so as to adversely affect its performance or reliability, except insofar as such repairs were repairs not conducted in accordance with the Contractor provided maintenance manuals and with workmanship performed by adequately trained personnel in accordance with recognized standards of the industry. The warranty shall also be void if Procuring Agency fails to conduct normal inspections and scheduled preventive maintenance procedures as recommended in the Contractor's maintenance manuals and that omission caused the part or component failure. Procuring Agency shall maintain documentation, auditable by the Contractor, verifying service activities in conformance with the Contractor's maintenance manuals.

2.7.2.3 Exceptions and Additions to Warranty

The warranty shall not apply to scheduled maintenance items and normal wear-out items such as light bulbs, belts, tires and tubes. The warranty shall not apply to items furnished by Procuring Agency such as fareboxes and other auxiliary equipment, except insofar as such equipment may be damaged by the failure of a part or component for which the Contractor is responsible.

2.7.2.4 Detection of Defects

If the Procuring Agency detects a defect within the warranty periods defined within the "Warranty Requirements", it shall notify the Contractor's representative within 20 working days. Within 5 working days after receipt of notification, the Contractor's representative shall either agree that the defect is in fact covered by warranty, or reserve judgment until the subsystem or component is inspected by the Contractor's representative or is removed and examined at the Procuring Agency's property or at the Contractor's plant. At that time, the status of warranty coverage on the subsystem or component shall be mutually resolved between the Procuring Agency and the Contractor. Work shall commence to correct the defect within 10 working days after receipt of notification and shall be conducted in accordance with Section "Repairs by Contractor".

2.7.2.5 Scope of Warranty Repairs

When warranty repairs are required, the Procuring Agency and the Contractor's representative shall agree, within 5 working days after notification, on the most appropriate course for the repairs and the exact scope of the repairs to be performed under the warranty. If no agreement is obtained within the 5-day period, the Procuring Agency reserves the right to commence the repairs in accordance with Section "Repairs by Procuring Agency".

2.7.2.6 Fleet Defects – Occurrence and Remedy

A Fleet Defect is defined as cumulative failures of any kind in the same components in the same or similar application, where such items covered by the warranty and such failures occur in the warranty period in the specified proportion of the coaches delivered under this contract. The proportion shall be 10% of the vehicles in that delivery.

The Contractor shall correct a Fleet Defect under the warranty provisions defined in "Repair Procedures". After correcting the Fleet Defect, the Procuring Agency and the Contractor shall mutually agree to and the Contractor shall promptly undertake and complete a work program reasonably designed to prevent the occurrence of the same Defect in all other coaches and spare parts purchased under this contract. Where the specific Fleet Defect can be solely attributed to particular identifiable part(s), the work

program shall include redesign and/or replacement of the defectively designed and/or manufactured part(s) in the entire fleet. In all other cases, the work program shall include inspection and/or correction of all of the coaches in the fleet via a mutually agreed to arrangement.

2.7.3 REPAIR PROCEDURES

2.7.3.1 Repair Performance

The Contractor is responsible for all warranty-covered repair work. To the extent practicable, Procuring Agency will allow the Contractor or its designated representative to perform such work. At its discretion, Procuring Agency may perform such work if Procuring Agency determines it necessary based on transit service or other requirements. Such work shall be reimbursed by the Contractor.

2.7.3.2 Repairs by Contractor

The Contractor or its designated representative shall begin work on warranty-covered repairs within 72 hours after receiving notification of a defect from Procuring Agency. The Procuring Agency shall make the coach available to complete repairs timely with the Contractor repair schedule.

The Contractor shall provide, at its own expense, all spare parts, tools, and space required to complete repairs. At the Procuring Agency's option, the Contractor may be required to remove the coach from Procuring Agency's property while repairs are being completed. If the coach is removed from the Procuring Agency's property, repair procedures must be diligently pursued by the Contractor's representative. All costs incurred by the removal of the Procuring Agency's coaches to and from the Contractor's repair facility are to be borne by the Contractor and reimbursable under warranty if the Procuring Agency's personnel are utilized to shift the coaches.

2.7.3.3 Repairs by Procuring Agency

2.7.3.3.1 Parts Used

If the Procuring Agency performs the warranty-covered repairs, it shall correct or repair the defect and any related defects utilizing parts supplied by the Contractor specifically for this repair. At its discretion, the Procuring Agency may use Contractor-specified parts available from its own stock if deemed in its best interest. Reports of all repairs covered by this warranty shall be submitted monthly or at a period to be mutually agreed upon by the Procuring Agency to the Contractor for reimbursement or replacement of parts. Efforts shall be made by both the Contractor and the Procuring Agency to automate warranty claims processing and record keeping.

2.7.3.3.2 Contractor Supplied Parts

Procuring Agency may require that the Contractor supply new parts for warranty-covered repairs being performed by the Procuring Agency. These parts shall be shipped prepaid to Procuring Agency from any source selected by the Contractor within 10 working days of receipt of the request for said parts. Parts supplied by the Contractor shall be Original Equipment Manufacturer (OEM) equivalent or superior to that used in the coach original manufacture. All parts shall include hardware, bolts, nuts, washers, and associated accessories that are normally supplied when replacement parts or kits are purchased.

2.7.3.3.3 Defective Components Return

The Contractor may request that parts covered by the warranty be returned to the manufacturing plant. The total cost for this action shall be paid by the Contractor. Materials should be returned in accordance with Contractor's instructions.

2.7.3.3.4 Failure Analysis

The Contractor shall, upon specific request by the Procuring Agency, provide a failure analysis of fleet defect- or safety-related parts or major components removed from coaches under the terms of the warranty that could affect fleet operation. Such reports shall be delivered within sixty (60) days of the receipt of failed parts.

2.7.3.3.5 Reimbursement for Labor

Procuring Agency shall be reimbursed by the Contractor for labor. The amount shall be determined by multiplying the number of man-hours actually required to correct the defect by an hourly rate to be negotiated with each Procuring Agency on an annual basis.

The rate shall not exceed the rates in effect in the Procuring Agency's service garage at the time the defect correction is made.

2.7.3.3.6 Reimbursement for Parts

Procuring Agency shall be reimbursed by the Contractor for defective parts and for parts that must be replaced to correct defects. The reimbursement shall be at the current price at the time of repair and shall include taxes (where applicable) and 20% handling costs.

2.7.3.3.7 Reimbursement Requirements

The Contractor shall reimburse Procuring Agency for warranty labor and/or parts within sixty (60) days of receipt of warranty claim.

2.7.3.3.8 Warranty after Repair/Replacement

If any component, unit, or subsystem is repaired, rebuilt, or replaced by the Contractor, or by the Procuring Agency with the concurrence of the Contractor; the component, unit, or subsystem shall have the un-expired warranty period of the original. Repairs shall not be warranted if Contractor-provided or authorized parts are not used for the repair, unless the Contractor has failed to respond within 5 days, in accordance with Section “Scope of Warranty Repairs”

The warranty on items determined to be Fleet Defects shall be guaranteed for the remainder of the warranty period or for one year, whichever period is greater. This extended warranty shall begin on the repair/replacement date for corrected items on each coach.

2.7.4 PROPRIETARY CHARGING SYSTEMS WARRANTY AND MAINTENANCE

If the vehicle will NOT require a proprietary charging system, this section will not apply.

2.7.4.1 Warranty

Proprietary charging systems, if required, should be warranted for a minimum of 5 years.

2.7.4.2 Preventative and Scheduled Maintenance

The Contractor shall provide a three (3) year service / maintenance contract for the routine maintenance and repair of the EVSE at no extra cost. This three-year period shall correspond to the start of the warranty period outlined here.

- This service contract shall include all maintenance required or recommended by the equipment and component manufacturers and all work that is normally provided by current industry best practice.
- A written maintenance plan and training must be provided to Procuring Agency prior to acceptance. The plan shall include, at a minimum, a 52-week preventative and scheduled maintenance and long-term capital rehab / replacement plan for the life of the system.
- Procuring Agency will use its own staff to provide weekly inspections as required to perform light inspection and service as documented in the maintenance plan.

- Contractor shall maintain a clean facility and shall dispose off-site of all waste material in an environmentally responsible and legal manner, being compliant with the Procuring Agency's Environmental Sustainability Management System (ESMS).
- Contractor shall maintain detailed records of all inspections, calibrations, tests, maintenance and repairs. Information shall be provided to the Procuring Agency on a timely basis for storage within the Procuring Agency's Enterprise Asset Management and Work Order System.

2.7.4.3 Responsibilities of parties

- The Contractor shall supply all parts and consumables included within the cost of the contract.
- The Contractor shall maintain an inventory of all required parts including consumables and major repair parts during the terms of this contract.
- The Procuring Agency will pay the cost of all gas, electric power, and communications to the station.
- The Procuring Agency will provide insurance on the property. Contractor will provide other insurance as indicated elsewhere in this document.

2.7.4.4 Unscheduled Repairs

The Contractor shall be responsible for maintaining and keeping the system operational 24 hours per day 7 days a week. The contractor is responsible for monitoring the performance of the system and be automatically notified when the system requires maintenance or becomes non-operational. Any non-emergency repairs can be scheduled as needed.

- The Contractor shall supply 60-minute call back and four-hour on-site response time (from time of a fault shutdown being transmitted either electronically or by phone whichever occurs first). At no time shall the equipment deliver less than 75 percent of firm capacity for more than 12 hours.
- If the contractor does not respond within the 1 to 4 hours, the Procuring Agency may have the problem repaired at their discretion and charge the contractor back the repair costs with a 15% markup against the monthly service billing.
- Callouts that are the result of Procuring Agency actions shall be charged to the Procuring Agency at regular time rates as proposed herein with no additional charges for overtime, premium, time, equipment or mileage charges.
- Cost of maintenance program shall be invoiced monthly.

2.7.4.5 Maintenance and Licenses

The Contractor shall be responsible for monitoring the performance of the EVSE and reporting the condition to the Procuring Agency on a monthly basis. The report should include any recommendations for improvements that improve the charging of the buses or reduce the overall operational costs during the duration of the contract.

2.7.4.6 Three-Year Maintenance Options

The Proposal shall include three (3) additional options to extend this three-year maintenance program for three years for each option, beginning in year four (4) through year twelve (12).

- All terms shall remain the same as the initial three-year program,
- All parts that fail or are no longer covered by Warranty shall be included in the cost of the contract such that the Procuring Agency will have no costs beyond the maintenance program charge.

Any scheduled major component replacements must be identified in a separate line item in the year of occurrence and only paid out upon the replacement.

2.8 Training, Manuals, and Parts List

2.8.1 TRAINING

2.8.1.1 On-Site Training

Procuring Agency shall be entitled to on-site training for each year of the three (3) year contract; proposals should include the number of hours anticipated to be provided by the Contractor for training. The training offered by the Contractor and Original Equipment Manufacturers (OEM) shall be for major components provided on the buses. The Training Program schedule will be discussed with Contractor after contract award to establish a training schedule that is properly coordinated with the delivery and acceptance of the buses. Training shall consist, at a minimum, of the following topics:

- 1) Body and Chassis
- 2) Suspension and Steering
- 3) Electrical and Electronics
- 4) Air and Brake System
- 5) Driver Controls
- 6) HVAC
- 7) Propulsion system
- 8) Propulsion Control System (PCS)
- 9) Power Distribution/ESS
- 10) Wheelchair ramp
- 11) Destination Signs
- 12) Service access locations
- 13) Diagnostic port locations
- 14) Locations of daily service items
- 15) Parts and Service Procedures
- 16) Charging Infrastructure
- 17) Charger Management System

At least one qualified instructor who will be available at the Procuring Agency's property at a time and for a duration mutually agreed to by both parties. Instructor(s) will conduct schools and advise the personnel of the Procuring Agency on the proper operation and maintenance of the equipment.

The Contractor will, at its own expense, have one or more competent technical service representatives located within four (4) hours of the Procuring Agency maintenance facility for a minimum of ninety (90) days following delivery of the first vehicle. Technical service representatives shall also be available on request to assist Procuring Agency in the solution of engineering or design problems within the scope of the specifications that

may arise during the warranty period. This does not relieve the Contractor of the responsibilities outlined under “Warranty Requirements”.

2.8.1.2 Online Support

Procuring Agency shall receive a login and password to access all chassis parts, service, and warranty information. This will give the Procuring Agency up-to-the-minute information concerning any recalls, etc. pertaining to their specific chassis. This will also give the Procuring Agency access to a unit-specific parts catalog.

2.8.2 MANUALS AND PARTS LIST

2.8.2.1 Required Manuals

As part of the Contract, the Contractor shall furnish, at a minimum, the manuals and material/parts cross reference list as indicated below and in accordance with the criteria specified herein:

DESCRIPTION	NUMBER OF COPIES*
Maintenance Manuals	1
Driver’s Operating Manuals (per bus)	10
Parts Manuals	1
Wiring Diagrams	1
Propulsion System Manuals	1
Propulsion System Troubleshooting Guide	1
Guide Parts Cross Reference List	1
Suggested spare parts list	1

*Quantities shown above are per series build.

2.8.2.2 Standards and Formats of Manuals

- (1) The manuals shall meet the standards and be presented in accordance with the format requirements of this specification. The material in all manuals shall be organized and indexed with a standard numbering system in accordance with an approved Contractor's outline. Each respective manual shall contain the same topics. The format of all data contained in each section of the manuals shall be logically organized with systems and elements considered in descending order of importance. Care shall be taken that all statements are clear, positive, and accurate, with no

possibility of incorrect implications. The manuals shall be complete, modern, and authentic, with no extraneous material such as advertisements or irrelevant information.

- (2) The maintenance and parts manuals shall be in three-ring loose-leaf binder form. The page size should be approximately 8-1/2 X 11 inches and all pages shall be laminated. Folded pages are permitted where the information cannot be presented clearly on a single page. Pages shall be secured in the binder along the eleven-inch page dimension. Required diagrams, illustrations and drawings shall not be loose or in binder pockets. All printed material shall be clearly reproducible by dry copying machines. Halftone illustrations are not acceptable.
- (3) Driver's Operating Manuals shall be approximately 4-1/4 X 7 inches is dimension. It is suggested that they be bound along the 7-inch dimension, and with no fold out or loose pages, or loose diagrams. Pages for drivers operating manuals shall not be laminated.
- (4) All manuals shall be designed for continuous, long-term service. Binder covers shall be resistant to oil, moisture, and wear commensurate with their intended use.
- (5) An electronic copy of each manual type shall be provided in addition to the hard copies described above.

2.8.2.3 Maintenance Manuals

Maintenance manuals shall contain complete data required for routine and periodic maintenance of all parts of the coach, including, but not limited to, the following:

- 1) General operation description.
- 2) Troubleshooting guide covering all mechanical, electrical and electronic components.
- 3) All preventive maintenance, lubrication, and adjustment requirements.
- 4) Complete wiring and schematic diagrams, schedules for wire and cable sizes and ratings including actual layout, as well as

detailed locations in the coach of all electrical and electronic components, including propulsion system.

- 5) Comprehensive diagrams, system detail, troubleshooting guidelines, preventive maintenance procedures, and repair instructions for the propulsion system and energy storage system.
- 6) Air and hydraulic system diagrams showing locations in the coach of air and hydraulic components.
- 7) Illustrative drawings, such as isometrics or exploded views, identifying components in relationship to each other as mounted in the buses.
- 8) Components shown in exploded views with all parts clearly identified.
- 9) Rebuilding procedures for all rebuildable components.
- 10) A list of all components to be disconnected, plus the specific terminations to disconnect, when electric welding is performed on the bus.
- 11) Detailed, well-illustrated procedures for component change-out plus servicing adjusting, testing, and run-in information as required.
- 12) Body and structural information and material specifications for major accident repairs.
- 13) Seating and stanchion layouts and window diagrams (may be included in parts manual).
- 14) Repair and calibration instructions and values.
- 15) Software information, including source codes for any programmed module or component, information on programmed array logic (PAL) and any other programmed device. Procuring Agency will consider all such data as proprietary. When legal liability concerns preclude access to source code, the vendor shall provide the Procuring Agency

with a list of EPROM parameters and place a copy of all software revisions in escrow giving the Procuring Agency access in case of vendor default.

- 16) Complete schematic drawings containing component identification and the location of components on the circuit board; circuit descriptions and theory of operation for all electronic components. Procuring Agency will consider all such data as proprietary.

Procuring Agency prefers that the Contractor's maintenance manual thoroughly describe the maintenance of all parts of the bus. Realizing that some specialized OEM manuals will be provided, Procuring Agency requires that the Contractor provide the following OEM vendor manuals and publications:

- 1) Bus electrical wiring diagrams.
- 2) Electrical system diagnostic and troubleshooting guides.
- 3) Electronic data control troubleshooting manuals.
- 4) Propulsion system service, troubleshooting, and overhaul manuals.
- 5) Transmission service, troubleshooting, and overhaul manuals.
- 6) HVAC system service, troubleshooting, and overhaul manuals.
- 7) Air system diagnostic and troubleshooting guides.
- 8) Comprehensive color-coded air system schematics.
- 9) Foundation brake system analysis and troubleshooting guides.
- 10) Anti-Lock Brake (ABS) and Automatic Traction Control (ATC) system service, troubleshooting, and overhaul manuals.
- 11) Differential and drive shaft service, troubleshooting, and overhaul manuals.
- 12) Steering column service, troubleshooting, and overhaul manuals.
- 13) Steering gear service, troubleshooting, and overhaul manuals.
- 14) Wheelchair ramp system service, troubleshooting, and overhaul manuals.
- 15) Fire suppression system service, troubleshooting, and overhaul manuals.

2.8.2.4 Driver's Operating Manuals

The Driver's Operating Manuals shall provide information and instructions for all phases of operation of the bus, including, but not limited to, bus mechanical operation, response to safety alarm systems, lighting system controls, emergency actions, maintenance checks, and turning characteristics of the bus.

2.8.2.5 Parts Manuals

The parts manuals shall enumerate and describe every component with its related parts, including the supplier's number, the Contractor's number, and the commercial equivalents. Cutaway and exploded drawings shall be used to permit identification of all parts. The drawings shall contain data arranged so that the part numbers can be readily found and identified in the drawing for each system and subsystem component, assembly, subassembly, or piece part from an orderly breakdown of the complete bus. They shall be indexed by part number and by part name and shall be sufficiently well illustrated to identify items requiring repair, replacement, and storage for use in the maintenance of buses. Isometric exploded views shall be used to identify each piece part. Price lists giving current net prices, including freight to the Procuring Agency's location, shall accompany all manuals.

2.8.2.5.1 Parts Cross Reference List

The Contractor shall provide a suppliers list that contains the manufacturer part number, part name, and description.

2.8.2.5.2 Spare Parts

The Contractor shall guarantee the availability of replacement parts for the buses for at least a twelve (12) year period after date of acceptance of buses by the Procuring Agency.

2.8.2.6 Revisions

Following the publication of each manual required herein, the Contractor shall provide revisions covering any changes, whether required by change of design or procedures or due to error, and these revisions shall be kept current during the warranty period. Manual revisions shall be furnished to the Procuring Agency before or coincidental with the arrival of any altered parts or components. After the warranty period, revisions shall be furnished to the Procuring Agency every six (6) months for a period of twelve (12) years.

2.8.2.7 Delivery

A preliminary wiring diagram is required with the delivery of the first bus. A final wiring diagram will be required within five (5) days of delivery of the last bus.

2.8.2.8 Wall Size Charts

The contractor shall supply two (2) wall charts displaying the following maintenance functions and/or component of the bus:

- 1) Lube chart
- 2) Air Brake system chart
- 3) Electrical chart
- 4) Exploded body/exterior skin chart
- 5) Air conditioning chart

2.9 Options / Alternates

2.9.1 SPECIAL TOOLS

Proposal shall include a list of special test equipment and tools required to maintain and repair systems down to the component level. One operator manual shall be provided for any special tool or diagnostic equipment purchased from the Contractor. The following information shall be provided in the proposal:

- 1) Manufacturer part number
- 2) Contractor purchase price for tool/equipment
- 3) Detail of use/function for maintenance of proposed buses

Any special tools required for routine maintenance of the vehicles shall be included with the delivery of the first bus at no extra cost.

In addition to the above, prices for each of the following tools shall be provided in the table below:

DINEX Part Number: G3-MK-808 / Description: Circuit Tester
 DINEX Part Number: G3-MK-Charger / Description: Program Loader
 DINEX Part Number: G3-MK-Program / Description: Program Module
 DIEX Part Number: G3-MK-CAN / Description: CAN Interface with DINEX G3 Utility
 DINEX Part Number: CSE-0078 / Description: Storage Case

2.9.2 OPTIONAL EQUIPMENT LIST

Proposers shall provide the cost that would be added or deducted from the price of each bus if Procuring Agency elects to include any of the following options that have been listed below.

#	Section	Description	Price per Unit
1	2.1.8.4 (p. 26)	Delete external decals	
2	2.1.9.10.1 (p. 31)	Add AMEREX V-25 fire suppression system	

3	2.2.1.5 (p. 32)	Delete Advertising Signs	
4	2.2.1.6 (p. 33)	Add Sportworks Apex 3 stainless steel bike rack in lieu of DL-2 bike rack	
5	2.2.2.4 (p. 34)	Delete 21" x 22" sign frame from Driver's barrier	
6	2.2.3.4 (p. 37)	Add Marine grade plywood in lieu of composite material for sub-floor.	
7	2.2.6 (p. 41)	Add electric-powered Vapor Bus doors in lieu of compressed air.	
8	2.2.12.4 (p. 55)	Add indicator light for deployment of bike rack	
9	2.2.13.2 (p. 60)	Add Recaro Ergo Metro driver's seat in lieu of USSC 9100ALX	
10	2.2.13.2 (p. 60)	Add Three air bag chamber lumbar adjustment in lieu of mechanical lumbar adjustment.	
11	2.2.14.2 (p. 62)	Add "full fixed" in lieu of "Tip-In over Fixed" side windows	
12	2.2.17.1.1 (p. 71)	Add dual driver's dash fans in lieu of single fan.	
13	2.2.17.1.1 (p. 71)	Remove driver's dash fan	
14	2.2.17.1.2 (p. 71)	Delete sun shade from right (passenger entry) side of windshield.	
15	2.2.17.2.1 (p. 72)	Select Safe Fleet 10"x11", 2-piece heated remote controlled mirrors w/ stainless steel black powder coated brackets	
16	2.2.17.2.1 (p. 72)	Add 15 minute timer to heated remote controlled mirrors	
17	2.2.17.4.2 (p. 77)	Add "Amber LED" illumination in lieu of white illumination.	
18	2.2.17.5.1 (p. 79)	Add Lift-U LU11 ramp in lieu of Lift-U LU18	
19	2.2.17.5.1 (p. 79)	Add Ricon FR2 4:1 ramp in lieu of Lift-U LU18	

20	2.2.17.5.4 (p. 81)	Add manually operated Q-Pod wheelchair securement system in lieu of Q-Straint securement system.	
21	2.3.2.3 (p. 85)	Add laptop computer installed with latest version of diagnostic software.	
22	2.3.10.5 (p. 101)	Select "SKF model HCT 2000 24-volt Heated Filtration Plus" Air Dryer	
23	2.3.11.2 (p. 102)	Select Michelin XZE 16 ply front tires and Michelin XDN2 16 ply rear tires	
24	2.3.11.2 (p. 102)	Add Transit-rated tires with reinforced sidewall.	
25	2.3.11.2 (p. 102)	Delete spare tires and rims	
26	2.4 (p. 104)	Add Cradlepoint IBR1700 Wi-Fi router with Panorama Low-profile dome 5 in 1 antenna	
27	2.4.5.1 (p. 117)	Add dash mounts for radio installation (no radio to be provided)	
28	2.4.6 (p. 118)	Add Seon Explorer DX12 system in lieu of Seon Explorer DXHD.	
29	2.4.6.10 (p. 119)	Add camera to system configuration	
30	2.4.6.10 (p. 119)	Remove camera from system configuration	
31	2.4.6.14 (p. 121)	Add laptop computer equipped with necessary software, hardware, and cabling provisions.	
32	2.5.1 (p. 122)	Add EVSE capable of connection to generator	
33	2.5.1 (p. 122)	Add additional EVSE (per port)	
34	2.5.1 (p. 122)	Add bus to bus charging capability	
35	2.5.4 (p. 126)	Add two-way power flow (vehicle-to-grid) capability to buses and charging infrastructure	
36	2.7.4.6 (p. 142)	Charging System Maintenance Option – Year Four through Six	

37	2.7.4.6 (p. 142)	Charging System Maintenance Option – Year Seven through Nine	
38	2.7.4.6 (p. 142)	Charging System Maintenance Option – Year Ten through Twelve	
39	2.9.1 (p. 150)	Lot price for additional sets of special tools required for maintenance of electric buses (price per set)	
40	2.9.1 (p. 150)	Add Circuit Tester (DINEX # G3-MK-808)	
41	2.9.1 (p. 150)	Add Program Loader (DINEX # G3-MK-Charger)	
42	2.9.1 (p. 150)	Add Program Module (DINEX # G3-MK-Program)	
43	2.9.1 (p. 150)	Add CAN Interface w/ DINEX G3 Utility (DINEX # G3-MK-CAN)	
44	2.9.1 (p. 150)	Add Storage Case (DINEX # CSE-0078)	

Heavy Duty Battery Electric Transit Bus

THIS FORM MUST BE SUBMITTED WITH THE BID AND SIGNED ACCORDINGLY

Date: _____

Proposal of: _____

Hereinafter called "Bidder", a (corporation) (partnership) (circle one)

Of the State of _____

Price per Bus

35' \$ _____

Model Year _____

Date of FTA Bus Test _____

Proposed Delivery Date _____

The Bidder, in compliance with the Request for Proposals, having examined the specifications hereby proposes to furnish the buses in accordance with the attached specifications, and any exceptions to the specifications will be clearly identified. The Bidder also understands that failure to adhere to these specifications unless otherwise noted, may result in the bid not being considered.

The undersigned, as Bidder, declare the only person or parties interested in this Proposal as principals are those named herein; that this Proposal is made without collusion with any other firm, and the undersigned will take in full payment.

Name of Firm _____

Phone Number _____

Street Address _____

City, State, Zip _____

Print Name & Title of Authorized Person _____

Signature of Authorized Person _____

A. Applicability

The following requirements and conditions shall be considered as an essential part of specifications and proposal. This document will serve as part of the contract for the project once the bid is awarded. If there is another contract document the following shall be considered part of that contract.

B. Energy Conservation

The Contractor agrees to comply with mandatory standards and policies relating to energy efficiency which are contained in the state energy conservation plan issued in compliance with the Energy Policy and Conservation Act pursuant to 42 USC 6321 and 49 CFR part 18.

C. Federal Changes

Contractor shall at all times comply with all applicable FTA regulations, policies, procedures and directives, including without limitation those listed directly or by reference in the current "Master Agreement" between the entities with rights to order buses under this procurement and FTA as they may be amended or promulgated from time to time during the term of this contract. Contractor's failure to so comply shall constitute a material breach of this contract.

D. Recycled Products

The Contractor agrees to comply with all the requirements of Section 6002 of the Resource Conservation and Recovery Act (RCRA), as amended (42 U.S.C. 6962), including but not limited to the regulatory provisions of 40 CFR Part 247, and Executive Order 12873, as they apply to the procurement of the items designated in Subpart B of 40 CFR Part 247.

E. No Government Obligation to Third Parties

MVRTD and Contractor acknowledge and agree that, notwithstanding any concurrence by the Federal Government in or approval of the solicitation or award of the underlying contract, absent the express written consent by the Federal Government, the Federal Government is not a party to this contract and shall not be subject to any obligations or liabilities to MVRTD, Contractor, or any other party (whether or not a party to that contract) pertaining to any matter resulting from the underlying contract.

The Contractor agrees to include the above clause in each subcontract financed in whole or in part with assistance provided by MVRTD. It is further agreed that the clause shall not be modified, except to identify the subcontractor who will be subject to its provisions.

F. Program Fraud and False or Fraudulent Statements or Related Acts

The Contractor acknowledges that the provisions of the Program Fraud Civil Remedies Act of 1986, as amended, 31 U.S.C. § 3801 et seq. and U.S. DOT regulations, "Program Fraud Civil Remedies," 49 C.F.R. Part 31, apply to its actions pertaining to this Project. Upon execution of the underlying contract, the Contractor certifies or affirms the truthfulness and accuracy of any statement it has made, it makes, it may make, or causes to be made, pertaining to the underlying contract or the FTA assisted project for which this contract work is being performed. In addition to other penalties that may be applicable, the Contractor further acknowledges that if it makes, or causes to be made, a false, fictitious, or fraudulent claim, statement, submission, or certification, the Federal Government reserves the right to impose the penalties of the Program Fraud Civil Remedies Act of 1986 on the Contractor to the extent the Federal Government deems appropriate.

The Contractor also acknowledges that if it makes, or causes to be made, a false, fictitious, or fraudulent claim, statement, submission, or certification to the Federal Government under a

contract connected with a project that is financed in whole or in part with Federal assistance originally awarded by FTA under the authority of 49 U.S.C. § 5307, the Government reserves the right to impose the penalties of 18 U.S.C. § 1001 and 49 U.S.C. § 5307(n)(1) on the Contractor, to the extent the Federal Government deems appropriate.

The Contractor agrees to include the above two clauses in each subcontract financed in whole or in part with Federal assistance provided by FTA. It is further agreed that the clauses shall not be modified, except to identify the subcontractor who will be subject to the provisions.

G. Privacy Act

The following requirements apply to the Contractor and its employees that administer any system of records on behalf of the Federal Government under any contract:

(1) The Contractor agrees to comply with, and assures the compliance of its employees with, the information restrictions and other applicable requirements of the Privacy Act of 1974, 5 U.S.C. § 552a. Among other things, the Contractor agrees to obtain the express consent of the Federal Government before the Contractor or its employees operate a system of records on behalf of the Federal Government. The Contractor understands that the requirements of the Privacy Act, including the civil and criminal penalties for violation of that Act, apply to those individuals involved, and that failure to comply with the terms of the Privacy Act may result in termination of the underlying contract.

(2) The Contractor also agrees to include these requirements in each subcontract to administer any system of records on behalf of the Federal Government financed in whole or in part with Federal assistance provided by FTA.

H. Civil Rights Requirements

The following requirements apply to the underlying contract:

(1) Nondiscrimination - In accordance with Title VI of the Civil Rights Act, as amended, 42 U.S.C. § 2000d, section 303 of the Age Discrimination Act of 1975, as amended, 42 U.S.C. § 6102, section 202 of the Americans with Disabilities Act of 1990, 42 U.S.C. § 12132, and Federal transit law at 49 U.S.C. § 5332, the Contractor agrees that it will not discriminate against any employee or applicant for employment because of race, color, creed, national origin, sex, age, or disability. In addition, the Contractor agrees to comply with applicable Federal implementing regulations and other implementing requirements FTA may issue.

(2) Equal Employment Opportunity - The following equal employment opportunity requirements apply to the underlying contract:

(a) Race, Color, Creed, National Origin, Sex - In accordance with Title VII of the Civil Rights Act, as amended, 42 U.S.C. § 2000e, and Federal transit laws at 49 U.S.C. § 5332, the Contractor agrees to comply with all applicable equal employment opportunity requirements of U.S. Department of Labor (U.S. DOL) regulations, "Office of Federal Contract Compliance Programs, Equal Employment Opportunity, Department of Labor," 41 C.F.R. Parts 60 et seq., (which implement Executive Order No. 11246, "Equal Employment Opportunity," as amended by Executive Order No. 11375, "Amending Executive Order 11246 Relating to Equal Employment Opportunity," 42 U.S.C. § 2000e note), and with any applicable Federal statutes, executive orders, regulations, and Federal policies that may in the future affect construction activities undertaken in the course of the Project. The Contractor agrees to take affirmative action to ensure that applicants are employed, and that employees are treated during employment, without regard to their race, color, creed, national origin, sex, or age. Such action shall include, but not be limited to, the following: employment, upgrading, demotion or transfer, recruitment or recruitment advertising, layoff or termination; rates of pay or other forms of

compensation; and selection for training, including apprenticeship. In addition, the Contractor agrees to comply with any implementing requirements FTA may issue.

(b) Age - In accordance with section 4 of the Age Discrimination in Employment Act of 1967, as amended, 29 U.S.C. § 623 and Federal transit law at 49 U.S.C. § 5332, the Contractor agrees to refrain from discrimination against present and prospective employees for reason of age. In addition, the Contractor agrees to comply with any implementing requirements FTA may issue.

(c) Disabilities - In accordance with section 102 of the Americans with Disabilities Act, as amended, 42 U.S.C. § 12112, the Contractor agrees that it will comply with the requirements of U.S. Equal Employment Opportunity Commission, "Regulations to Implement the Equal Employment Provisions of the Americans with Disabilities Act," 29 C.F.R. Part 1630, pertaining to employment of persons with disabilities. In addition, the Contractor agrees to comply with any implementing requirements FTA may issue.

(3) The Contractor also agrees to include these requirements in each subcontract financed in whole or in part with Federal assistance provided by FTA, modified only if necessary to identify the affected parties.

I. Incorporation of FTA Terms

The preceding provisions include, in part, certain Standard Terms and Conditions required by DOT, whether or not expressly set forth in the preceding contract provisions. All contractual provisions required by DOT, as set forth in FTA Circular 4220.1E, dated June 19, 2003, are hereby incorporated by reference. Anything to the contrary herein notwithstanding, all FTA mandated terms shall be deemed to control in the event of a conflict with other provisions contained in this Agreement. The Contractor shall not perform any act, fail to perform any act, or refuse to comply with any MVRTD requests which would cause MVRTD or parties to this procurement to be in violation of the FTA terms and conditions.

J. Nondiscrimination - Title VI of the Civil Rights Act

The Contractor and any subcontractor agree to comply with all requirements prohibiting discrimination on the basis of race, color, or national origin of Title VI of the Civil Rights Act of 1964, as amended, 42 U.S.C. § 2000d, and U.S. DOT regulations, "Nondiscrimination in Federally-Assisted Programs of the Department of Transportation -- Effectuation of Title VI of the Civil Rights Act," 49 C.F.R. Part 21, and any implementing requirements FTA may issue.

The Contractor must include the above statement in any subcontract.

K. Interest of Member of, or Delegates to, Congress

No member of, or delegate to, the Congress of the United States, shall be admitted to any share or part of this contract, or to any benefit arising therefrom.

L. Conflict of Interest

The officers, employees or agents of the Chittenden County Transportation Authority shall neither solicit nor accept gratuities, favors, or anything of monetary value from Contractors, potential Contractors, or parties to sub-agreements.

M. Prohibited Interests

No employee, officer, board member, or agent of MVRTD, who is involved in contract

specifications, solicitations, selection, or award, shall have any interests in this contract, or the proceeds thereof. In addition, no immediate family members or partners of an employee, officer, board member, or agent of MVRTD who is involved in contract specifications, solicitations, selection, or award, shall have any interests in this contract, or the proceeds thereof. Nor shall any organization that employs or is about to employ an employee, officer, board member, or agent of MVRTD who is involved in contract specifications, solicitations, selection, or award, shall have any interests in this contract, or the proceeds thereof. Finally, no organization that employs or is about to employ any immediate family members or partners of an employee, officer, board member, or agent of MVRTD who is involved in contract specifications, solicitations, selection, or award, shall have any interests in this contract, or the proceeds thereof.

N. Tax Exemption and Tax Issues

MVRTD and entities with rights to order buses under this procurement are generally exempt from payment of all Federal, State, and local taxes. Said taxes must not be included in bid prices. MVRTD and entities with rights to order buses under this procurement will provide necessary tax exemption information upon request of Contractor after contract award. Contractor shall pay promptly all taxes, excises, license fees and permit fees of whatever nature, applicable to its operations hereunder and take out, pay for, and keep current all licenses, municipal, state, and federal, required for the conduct of its business pursuant to this contract, and further agrees not to permit any of the said taxes excises, or license fees to become delinquent.

O. Lawful Business Conduct

The Contractor shall conduct its business and perform services pursuant to this contract in a lawful manner, and shall fully comply at all times with all federal, state, and local laws in connection with its business operations.

P. Bid Rejection or Cancellation

MVRTD reserves the right to waive any minor bid informalities or irregularities which are not crucial to the bid or prejudice against other bidders and/or to reject, for compelling reasons, any and all bids submitted. MVRTD may reject all bids or cancel the solicitation before opening if it is deemed by MVRTD to be in its best interest to do so.

Q. Non-Collusion

The bidder guarantees that the bid submitted is not a product of collusion with any other bidder and no effort has been made to fix the bid price for any bidder or to fix any overhead, profit or cost element of any bid price. An affidavit of Non-Collusion, as per attached format, must be signed and submitted with bid (Attachment A.)

R. Notices

All required notices relating to individual bus orders shall be provided to the same title at the same organization which issued the bus order by Certified Mail, Return Receipt Requested.

The bidders shall identify the person and address to whom notices to the bidder shall be given in connection with the bid.

S. Independent Status of MVRTD and Contractor

The Contractor recognizes and acknowledges that neither it nor any of its employees are agents or employees or volunteers of MVRTD, its members, and entities with rights to order buses under

this procurement, and that Contractor is and shall remain an independent Contractor in the performance of all services hereunder. Contractor understands that MVRTD, its members, and entities with rights to order buses under this procurement will not provide the employees or volunteers of the contractor with any individual fringe benefits, workers compensation or other benefits or services available to the employees of MVRTD, its members, and entities with rights to order buses under this procurement, nor will MVRTD, its members, or entities with rights to order buses under this procurement withhold any state or federal taxes except as required under applicable tax laws, which shall be determined in advance of execution of the contract. All tax returns required by the Vermont Department of Taxes or the United States Internal Revenue Service must be filed by the contractor and information as to contract income paid under this contract will be provided by MVRTD, its members, or entities with rights to order buses under this procurement to the Vermont Department of Taxes and the U.S. Internal Revenue Service.

T. Late Bids

Bids received after the exact time set for opening are late bids and will not be considered for award, unless it is determined by MVRTD, that there was mishandling on MVRTD's part.

U. Modifications and Withdrawals of Bids

Bids may be withdrawn through written notice (including email, fax, USPS, etc.) received at any time before the exact time set for receipt of bids. A bid may be withdrawn in person by a bidder or its authorized representative if, before the exact time set for receipt of bids, the identity of the person requesting withdrawal is established as an authorized officer of the company and the person signs a receipt for the bid.

V. Period of Acceptance of Bids

The bidder agrees, if this bid is accepted within 120 calendar days from the date specified in the solicitation for receipt of bids, to enter into a contract and/or furnish any or all items upon which prices are bid at the price set opposite each item, delivered at the designated points(s), within the time specified.

W. Bid Acceptance or Rejection

MVRTD may accept any bid or reject any or all bids (even after opening), or to award the contract on such basis as MVRTD deems in its best interest.

X. Right Infringement

Contractor agrees to save, keep, and hold harmless, and fully indemnify MVRTD, its members, and entities with rights to order buses under this procurement, including any officers or agents from all damages, cost, or expenses in law or equity, that may at any time be claimed against MVRTD, its members, and entities with rights to order buses under this procurement for or in connection with any infringement of the patent, trademark, copyright or other rights of any person or persons as a consequence of the use by MVRTD, its members, and entities with rights to order buses under this procurement, including any officers or agents, of any product or service supplied under the contract, arising from bids submitted, and any claim that the bidder did not have all necessary right and authority to sell the products or services to MVRTD, its members, and entities with rights to order buses under this procurement, provided MVRTD gives the Contractor prompt notice in writing of any such claim.

Y. Firm Information for MVRTD Bidders List

Fill out attachment B in entirety and return with proposal or bid. In addition, for EACH subcontractor, who may be working for your firm under this contract, copy and fill out sub-

contractor information.

Z. References

If references are mentioned in the RFP or Bid Specification as an evaluation criterion and the proposer/bidder is a past (within 10 years) or current contractor, internal references may, at MVRTD's sole discretion, be substituted entirely or in part for external references. This section supersedes all portions of the RFP or Bid which reference this issue.

Attachment A

Affidavit of Non-Collusion

I hereby swear (or affirm) under penalty of perjury:

1. That I am the bidder (if the bidder is an individual), a partner in the bid (if the bidder is a partnership), or an officer or employee of the bidding corporation having authority to sign on its behalf (if the bidder is a corporation);
2. That the attached bid or bids has been arrived at by the bidder independently and have been submitted without collusion and without any agreement, understanding, or planned common course of action with any other vendor of materials, supplies, equipment, or service described in the invitation to bid, designed to limit independent bids or competition;
3. That the contents of the bid or bids has not been communicated by the bidder or its employees or agents to any person not an employee or agent of the bidder or its surety on any bond furnished with the bid or bids, and will not be communicated to any such person prior to the official opening of the bid or bids; and
4. That I have fully informed myself regarding the accuracy of the statements made in this affidavit.

Date _____

Signature _____

Company Name _____

Title _____

Subscribed and sworn to me before this ___ day of _____ 20___

Notary Public

My commission expires _____

Proposers E.I Number _____
(number used on employers Quarterly Federal Tax
Return)

Attachment B (page 1 of 3)

Firm Information for MVRTD Bidders List

1. Prime Contractor Information

- a. Firm Name _____
- b. Age of Firm _____
(number of years doing business under current name and or incorporation)
- c. Firm's Annual Gross Receipts (most recent completed/audited year) _____
- d. Name of Project for which Proposal was submitted _____
- e. Is firm a VAOT approved DBE? Yes No

2. Subcontractor Information

Subcontractor 1

- a. Firm Name (Subcontractor 1) _____
- b. Age of Firm _____
(number of years doing business under current name and or incorporation)
- c. Firm's Annual Gross Receipts (most recent completed/audited year) _____
- d. Name of Project for which Proposal was submitted _____
- e. Is firm a VAOT approved DBE? Yes No
- f. If yes, what is the amount of the proposed contract with this DBE firm? \$ _____

Subcontractor 2

- a. Firm Name (Subcontractor 2) _____
- b. Age of Firm _____
(number of years doing business under current name and or incorporation)
- c. Firm's Annual Gross Receipts (most recent completed/audited year) _____
- d. Name of Project for which Proposal was submitted _____
- e. Is firm a VAOT approved DBE? Yes No
- f. If yes, what is the amount of the proposed contract with this DBE firm? \$ _____

Attachment B (page 2 of 3)

Firm Information for MVRTD Bidders List

Subcontractor 3

- a. Firm Name (Subcontractor 3) _____
- b. Age of Firm _____
(number of years doing business under current name and or incorporation)
- c. Firm's Annual Gross Receipts (most recent completed/audited year) _____
- d. Name of Project for which Proposal was submitted _____
- e. Is firm a VAOT approved DBE? Yes No
- f. If yes, what is the amount of the proposed contract with this DBE firm? \$ _____

Subcontractor 4

- a. Firm Name (Subcontractor 4) _____
- b. Age of Firm _____
(number of years doing business under current name and or incorporation)
- c. Firm's Annual Gross Receipts (most recent completed/audited year) _____
- d. Name of Project for which Proposal was submitted _____
- e. Is firm a VAOT approved DBE? Yes No
- f. If yes, what is the amount of the proposed contract with this DBE firm? \$ _____

Subcontractor 5

- a. Firm Name (Subcontractor 5) _____
- b. Age of Firm _____
(number of years doing business under current name and or incorporation)
- c. Firm's Annual Gross Receipts (most recent completed/audited year) _____
- d. Name of Project for which Proposal was submitted _____
- e. Is firm a VAOT approved DBE? Yes No
- f. If yes, what is the amount of the proposed contract with this DBE firm? \$ _____

Attachment B (page 3 of 3)

Firm Information for MVRTD Bidders List

Subcontractor 6

- a. Firm Name (Subcontractor 6) _____
- b. Age of Firm _____
(number of years doing business under current name and or incorporation)
- c. Firm's Annual Gross Receipts (most recent completed/audited year) _____
- d. Name of Project for which Proposal was submitted _____
- e. Is firm a VAOT approved DBE? Yes No
- f. If yes, what is the amount of the proposed contract with this DBE firm? \$ _____

Subcontractor 7

- a. Firm Name (Subcontractor 7) _____
- b. Age of Firm _____
(number of years doing business under current name and or incorporation)
- c. Firm's Annual Gross Receipts (most recent completed/audited year) _____
- d. Name of Project for which Proposal was submitted _____
- e. Is firm a VAOT approved DBE? Yes No
- f. If yes, what is the amount of the proposed contract with this DBE firm? \$ _____

MVRTD Internal Use Only

Procurement Officer determine status:

- 1. MVRTD/VT UCP DBE (Y/N) _____
- 2. Included on Bidder List (date) _____

1. Proved Applicability

The following requirements and conditions shall be considered as an essential part of specifications and proposal. This document will serve as part of the contract for the project once the bid is awarded. If there is another contract document the following shall be considered part of that contract.

2. Buy America

The contractor agrees to comply with 49 U.S.C. 5323(j) and 49 CFR Part 661, as amended by Section 3011 of the FAST Act, which provide that Federal funds may not be obligated unless steel, iron, and manufactured products used in FTA-funded projects are produced in the United States, unless a waiver has been granted by FTA or the product is subject to a general waiver. General waivers are listed in 49 CFR 661.7, and microcomputer equipment, software, and small purchases (currently less than \$100,000) made with capital, operating, or planning funds. Separate requirements for rolling stock are set out at 5323(j)(2)(C) and 49 CFR 661.11, and are updated per Section 3011 of the FAST Act. Rolling stock not subject to a general waiver must be manufactured in the United States and have a domestic content equal to the percentages described in Section 3011 of the FAST Act for the Federal Fiscal Year (FFY) of production.

A bidder or offeror must submit to MVRTD the appropriate Buy America certification (Attachment 3 for rolling stock and related purchases) with all bids on FTA-funded contracts, except those subject to a general waiver. Bids or offers that are not accompanied by a completed Buy America certification must be rejected as nonresponsive. This requirement does not apply to lower tier subcontractors.

The Bidder shall also submit to MVRTD the following Pre-Award Vendor Domestic Content Data as follows: a) Proposed domestic content of vehicle components to determine that the United States content requirement at the time of production is met; b) Proposed final assembly location; and c) Manufacturing activities that will take place during final assembly.

The manufacturer shall provide enough detail about these activities to allow for the determination that these activities would constitute adequate final assembly under Buy America requirements.

3. Fly America

The Contractor agrees to comply with 49 U.S.C. 40118 (the "Fly America" Act) in accordance with the General Services Administration's regulations at 41 CFR Part 301-10, which provide that recipients (the parties having used the procurement to order buses) and subrecipients of Federal funds and their contractors are required to use U.S. Flag air carriers for U.S Government-financed international air travel and transportation of their personal effects or property, to the extent such service is available, unless travel by foreign air carrier is a matter of necessity, as defined by the Fly America Act. The Contractor shall submit, if a foreign air carrier was used, an appropriate certification or memorandum to the party having used this procurement to order buses, adequately explaining why service by a U.S. flag air carrier was not available or why it was necessary to use a foreign air carrier and shall, in any event, provide a certificate of compliance with the Fly America requirements. The Contractor agrees to include the requirements of this section in all subcontracts that may involve international air transportation.

4. Security for Performance in Bids

A bid guaranty issued by a fully qualified surety company acceptable to MVRTD and listed as a company currently authorized under 31 CFR, Part 223 (specified in section on Qualifications of Surety below) as possessing a Certificate of Authority is required from each bidder equivalent to five (5) percent of the 35' Vehicle base price for the estimated minimum quantity as established in Section III of this RFP. The "bid guaranty" shall consist of a firm commitment

such as a bid bond, certified check, irrevocable letter of credit, or other negotiable instrument accompanying a bid as assurance that the bidder will, upon MVRTD's acceptance of its bid, execute such contractual documents as may be required within one-hundred twenty (120) days after the bid is submitted. After bidder is selected and contract details are sufficiently agreed upon, MVRTD will return all bid bonds except for the selected bidder. The selected bidder will have their bid bond returned after execution of the contract and submission of required sureties such as performance and payment bonds and other requirements prior to beginning work.

In submitting this bid, it is understood and agreed by bidder that the right is reserved by MVRTD to reject any and all bids, or part of any bid, and it is agreed that the Bid may not be withdrawn for a period of one- hundred twenty (120) days subsequent to the opening of bids, without the written consent of MVRTD.

It is also understood and agreed that if the bidder should withdraw any part or all of his bid within one- hundred twenty (120) days after the bid opening without the written consent of MVRTD, shall refuse or be unable to enter into this Contract, or refuse or be unable to furnish adequate and acceptable Performance Bonds and Labor and Material Payments Bonds, or refuse or be unable to furnish adequate and acceptable insurance, he shall forfeit his bid security.

It is further understood and agreed that to the extent the defaulting bidder's Bid Bond, Certified Check, Cashier's Check, Treasurer's Check, and/or Official Bank Check (excluding any income generated thereby which has been retained by MVRTD) shall prove inadequate to fully recompense MVRTD for the damages occasioned by default, then the bidder agrees to indemnify MVRTD and pay over to MVRTD the difference between the bid security and MVRTD's total damages, so as to make MVRTD whole.

The bidder understands that any material alteration of any of the above or any of the material contained on this form (Attachment 4), other than that requested, will render the bid unresponsive.

Attorneys-in-fact who sign bid bonds or payment and performance bonds must file with each bond a certified and effective dated copy of their power of attorney.

5. Qualifications of Surety

A Bid Bond and Performance and Payment Bond must be executed by a surety company of recognized standing, authorized to do business in the State of Vermont as a surety company, having a resident agent in the State of Vermont and having been in business with a record of successful continuous operation for at least five years. In addition to the above minimum qualifications, the surety company must meet at least one of the following additional qualifications:

- a. The surety company will hold a current certificate of authority as acceptable surety on federal bonds in accordance with the United States Department of Treasury Circular 570, Current Revisions. If the amount of the Bond exceeds the underwriting limitation set forth in the circular, in order to qualify the net retention of the surety company will not exceed the underwriting limitation of the circular, and the excess risks must be protected by coinsurance, reinsurance, or other methods in accordance with Treasury Circular 297, revised September 1, 1978 (31 CFR Section 223.10 Section 233.111). Further, the surety company will provide the MVRTD with evidence satisfactory to the MVRTD, that such excess risk has been protected in an acceptable manner.
- b. The surety company shall have a Best's rating of A VII or better or a rating otherwise acceptable to MVRTD. (Ratings lower than A VII must be approved by MVRTD)

in writing prior to submitting bid or proposal to MVRTD).

6. Bus Testing

The Contractor [Manufacturer] agrees to comply with 49 U.S.C. A 5323(c) and FTA's implementing regulation at 49 CFR Part 665 and shall perform the following:

- 1) A manufacturer of a new bus model or a bus produced with a major change in components or configuration shall provide a copy of the final test report to MVRTD at a point in the procurement process specified by MVRTD which will be prior to the recipient's final acceptance of the first vehicle.
- 2) A manufacturer who releases a report under paragraph 1 above shall provide notice to the operator of the testing facility that the report is available to the public.
- 3) If the manufacturer represents that the vehicle was previously tested, the vehicle being sold should have the identical configuration and major components as the vehicle in the test report, which must be provided to the recipient prior to recipient's final acceptance of the first vehicle. If the configuration or components are not identical, the manufacturer shall provide a description of the change and the manufacturer's basis for concluding that it is not a major change requiring additional testing.
- 4) If the manufacturer represents that the vehicle is "grandfathered" (has been used in mass transit service in the United States before October 1, 1988, and is currently being produced without a major change in configuration or components), the manufacturer shall provide the name and address of the recipient of such a vehicle and the details of that vehicle's configuration and major components.

Attachment 8 must be filled out and returned to MVRTD with the bid or proposal. Bidders must also include a copy of the Altoona testing report for the bus(es) proposed.

7. Pre Award and Post Delivery Audit

The Contractor agrees to comply with 49 U.S.C. § 5323(l) and FTA's implementing regulation at 49 C.F.R. Part 663 and to submit the following certifications:

1. Buy America Requirements: The Contractor shall complete and submit a declaration certifying either compliance or noncompliance with Buy America. If the Bidder/Offeror certifies compliance with Buy America, it shall submit documentation which lists: 1) component and subcomponent parts of the rolling stock to be purchased identified by manufacturer of the parts, their country of origin and costs; and 2) the location of the final assembly point for the rolling stock, including a description of the activities that will take place at the final assembly point and the cost of final assembly.
2. Solicitation Specification Requirements: The Contractor shall submit evidence that it will be capable of meeting the bid specifications.
3. Federal Motor Vehicle Safety Standards (FMVSS): The Contractor shall submit 1) manufacturer's FMVSS self-certification sticker information that the vehicle complies with relevant FMVSS or 2) manufacturer's certified statement that the contracted buses will not be subject to FMVSS regulations.

Attachment 9 must be filled out and returned to MVRTD with the bid or proposal.

Attachment 10 must be submitted to the party having used the procurement to order buses before payment for vehicles.

8. Lobbying

Contractors who apply or bid for an award of \$100,000 or more shall file the certification required by 49 CFR part 20, "New Restrictions on Lobbying." Each tier certifies to the tier above that it will not and has not used Federal appropriated funds to pay any person or organization for influencing or attempting to influence an officer or employee of any agency, a member of Congress, officer or employee of Congress, or an employee of a member of Congress in connection with obtaining any Federal contract, grant or any other award covered by 31 U.S.C. 1352. Each tier shall also disclose the name of any registrant under the Lobbying Disclosure Act of 1995 who has made lobbying contacts on its behalf with non-Federal funds with respect to that Federal contract, grant or award covered by 31 U.S.C. 1352. Such disclosures are forwarded from tier to tier up to the recipient.

Attachment 11 must be filled out and returned to MVRTD with the bid or proposal.

9. Access to Records and Reports

The following access to records requirements apply to this Contract:

- a. The Contractor agrees to provide the party having used the procurement to order buses, the FTA Administrator, the Comptroller General of the United States or any of their authorized representatives access to any books, documents, papers and records of the Contractor which are directly pertinent to this contract for the purposes of making audits, examinations, excerpts and transcriptions. Contractor also agrees, pursuant to 49 C. F. R. 633.17 to provide the FTA Administrator or his authorized representatives including any PMO Contractor access to Contractor's records and construction sites pertaining to a major capital project, defined at 49 U.S.C. 5302(a)1, which is receiving federal financial assistance through the programs described at 49 U.S.C. 5307, 5309 or 5311.
- b. The Contractor shall make available records related to the contract for a capital project or improvement (defined at 49 U.S.C. 5302(a)1) to the party having used the procurement to order buses, the Secretary of Transportation and the Comptroller General or any authorized officer or employee of any of them for the purposes of conducting an audit and inspection.
- c. The Contractor agrees to permit any of the foregoing parties to reproduce by any means whatsoever or to copy excerpts and transcriptions as reasonably needed.
- d. The Contractor agrees to maintain all books, records, accounts and reports required under this contract for a period of not less than three years after the date of termination or expiration of this contract, except in the event of litigation or settlement of claims arising from the performance of this contract, in which case Contractor agrees to maintain same until the party having used the procurement to order buses, the FTA Administrator, the Comptroller General, or any of their duly authorized representatives, have disposed of all such litigation, appeals, claims or exceptions related thereto. Reference 49 CFR 18.39(i)(11).

10. Contract Work Hours

(1) Overtime requirements - No contractor or subcontractor contracting for any part of the contract work which may require or involve the employment of laborers or mechanics shall require or permit any such laborer or mechanic in any workweek in which he or she is employed on such work to work in excess of forty hours in such workweek unless such laborer or mechanic receives compensation at a rate not less than one and one-half times the basic rate of pay for all

hours worked in excess of forty hours in such workweek.

(2) Violation; liability for unpaid wages; liquidated damages - In the event of any violation of the clause set forth in paragraph (1) of this section the contractor and any subcontractor responsible therefor shall be liable for the unpaid wages. In addition, such contractor and subcontractor shall be liable to the United States for liquidated damages. Such liquidated damages shall be computed with respect to each individual laborer or mechanic, including watchmen and guards, employed in violation of the clause set forth in paragraph (1) of this section, in the sum of \$ 10 for each calendar day on which such individual was required or permitted to work in excess of the standard workweek of forty hours without payment of the overtime wages required by the clause set forth in paragraph (1) of this section.

(3) Withholding for unpaid wages and liquidated damages - the party having used the procurement to order buses shall upon its own action or upon written request of an authorized representative of the Department of Labor withhold or cause to be withheld, from any moneys payable on account of work performed by the contractor or subcontractor under any such contract or any other Federal contract with the same prime contractor, or any other federally-assisted contract subject to the Contract Work Hours and Safety Standards Act, which is held by the same prime contractor, such sums as may be determined to be necessary to satisfy any liabilities of such contractor or subcontractor for unpaid wages and liquidated damages as provided in the clause set forth in paragraph (2) of this section.

(4) Subcontracts - The contractor or subcontractor shall insert in any subcontracts the clauses set forth in this section and also a clause requiring the subcontractors to include these clauses in any lower tier subcontracts. The prime contractor shall be responsible for compliance by any subcontractor or lower tier subcontractor with the clauses set forth in this section.

(5) Payrolls and basic records - (i) Payrolls and basic records relating thereto shall be maintained by the contractor during the course of the work and preserved for a period of three years thereafter for all laborers and mechanics working at the site of the work (or under the United States Housing Act of 1937, or under the Housing Act of 1949, in the construction or development of the project). Such records shall contain the name, address, and social security number of each such worker, his or her correct classification, hourly rates of wages paid (including rates of contributions or costs anticipated for bona fide fringe benefits or cash equivalents thereof of the types described in section 1(b)(2)(B) of the Davis-Bacon Act), daily and weekly number of hours worked, deductions made and actual wages paid. Whenever the Secretary of Labor has found under 29 CFR 5.5(a)(1)(iv) that the wages of any laborer or mechanic include the amount of any costs reasonably anticipated in providing benefits under a plan or program described in section 1(b)(2)(B) of the Davis-Bacon Act, the contractor shall maintain records which show that the commitment to provide such benefits is enforceable, that the plan or program is financially responsible, and that the plan or program has been communicated in writing to the laborers or mechanics affected, and records which show the costs anticipated or the actual cost incurred in providing such benefits. Contractors employing apprentices or trainees under approved programs shall maintain written evidence of the registration of apprenticeship programs and certification of trainee programs, the registration of the apprentices and trainees, and the ratios and wage rates prescribed in the applicable programs.

11. Default and Termination

1. General Termination Provisions-Transportation Services, Professional Services, Supplies, Other Services, Service, and Transit Services Contracts.

a. Termination for Convenience

MVRTD, or a party entitled to use this procurement to procure buses may terminate this contract, in whole or in part, at any time by written notice to the Contractor when it is in best interest of the party having used the procurement to order buses. The Contractor shall be paid its fees or its costs, and profit on work performed up to the time of termination, but no unearned profit or fees on work not yet performed. The Contractor shall promptly submit its termination claim to the party having used the procurement to order buses to be paid the Contractor. If the Contractor has any property in its possession belonging to the party having used the procurement to order buses, the Contractor will account for the same, and dispose of it in the manner the party having used the procurement to order buses directs.

b. Termination for Default

If the Contractor does not deliver supplies in accordance with the contract delivery schedule; or if the contract is for services, the Contractor fails to perform in the manner called for in the contract; or if the Contractor fails to comply with any other provisions of the contract, the party having used the procurement to order buses may terminate this contract for default. Termination shall be effected by serving a notice of termination on the contractor setting forth the manner in which the Contractor is in default. The contractor will only be paid the contract price for supplies delivered and accepted, or services performed in accordance with the manner of performance set forth in the contract, offset by any damage incurred by virtue of Contractor's default.

If it is later determined by the party having used the procurement to order buses that the Contractor had an excusable reason for not performing, such as a strike, fire, or flood, events which are not the fault of or are beyond the control of the Contractor, the party having used the procurement to order buses, after setting up a new delivery of performance schedule, may allow the Contractor to continue work, or treat the termination as a termination for convenience.

c. Opportunity to Cure

The party having used the procurement to order buses in its sole discretion may, in the case of a termination for breach or default, allow the Contractor ten (10) days in which to cure the defect. In such case, the notice of termination will state the time period in which cure is permitted and other appropriate conditions.

If the party having used the procurement to order buses elects to give the Contractor an opportunity to cure and Contractor fails to remedy to the satisfaction of the party having used the procurement to order buses the breach or default or any of the terms, covenants, or conditions of this Contract within ten (10) days after receipt by Contractor of written notice from the party having used the procurement to order buses setting forth the nature of said breach or default, the party having used the procurement to order buses shall have the right to terminate the Contract without any further obligation to Contractor. Any such termination for default shall not in any way operate to preclude the party having used the procurement to order buses from also pursuing all available remedies against Contractor and its sureties for said breach or default.

d. Waiver of Remedies for any Breach

In the event that the party having used the procurement to order buses elects to waive its remedies for any breach by Contractor of any covenant, term, or condition of this Contract, such waiver by the party having used the procurement to order buses shall not limit said party's remedies for any succeeding breach of that or of any other term, covenant, or condition of this Contract.

12. Clean Water Requirements

The Contractor agrees to comply with all applicable standards, orders or regulations issued pursuant to the Federal Water Pollution Control Act, as amended, 33 U.S.C. 1251 et seq. The Contractor agrees to report each violation to the party having used the procurement to order buses and understands and agrees that the party having used the procurement to order buses will, in turn, report each violation as required to assure notification to FTA and the appropriate EPA Regional Office.

The Contractor also agrees to include these requirements in each subcontract exceeding \$100,000 financed in whole or in part with Federal assistance provided by FTA or the party having used the procurement to order buses.

13. Clean Air and Excluded Facilities

The Contractor agrees to comply with all applicable standards, orders or regulations issued pursuant to the Clean Air Act, as amended, 42 U.S.C. §§ 7401 et seq . The Contractor agrees to report each violation to the party having used the procurement to order buses and understands and agrees that the party having used the procurement to order buses will, in turn, report each violation as required to assure notification to FTA and the appropriate EPA Regional Office.

The contractor also agrees to comply with the provisions of 40 CFR Part 15 which prohibits the use of facilities included on the EPA list of violating facilities.

The Contractor also agrees to include these requirements in each subcontract exceeding \$100,000 financed in whole or in part with assistance provided by the party having used the procurement to order buses.

14. Debarment (Suspension from Gov't Purchases)

1. By signing and submitting this bid or proposal, the prospective lower tier participant is providing the signed certification set out below in Attachment 13.
2. The certification in this clause is a material representation of fact upon which reliance was placed when this transaction was entered into. If it is later determined that the prospective lower tier participant knowingly rendered an erroneous certification, in addition to other remedies available to the Federal Government, MVRTD or parties having used the procurement to order buses may pursue available remedies, including suspension and/or debarment.
3. The prospective lower tier participant shall provide immediate written notice to the party having used the procurement to order buses if at any time the prospective lower tier participant learns that its certification was erroneous when submitted or has become erroneous by reason of changed circumstances.
4. The terms "covered transaction," "debarred," "suspended," "ineligible," "lower tier covered transaction," "participant," "persons," "lower tier covered transaction," "principal," "proposal," and "voluntarily excluded," as used in this clause, have the meanings set out in the Definitions and Coverage sections of rules implementing Executive Order 12549 [49 CFR Part 29]. You may contact MVRTD for assistance in obtaining a copy of those regulations.
5. The prospective lower tier participant agrees by submitting this proposal that, should the proposed covered transaction be entered into, it shall not knowingly enter into any lower tier covered transaction with a person who is debarred, suspended, declared ineligible, or voluntarily excluded from participation in this covered transaction, unless authorized in writing by MVRTD.
6. The prospective lower tier participant further agrees by submitting this proposal that it will include the clause titled "Certification Regarding Debarment, Suspension, Ineligibility and

Voluntary Exclusion - Lower Tier Covered Transaction", without modification, in all lower tier covered transactions (subcontracts) and in all solicitations for lower tier covered transactions.

7. A participant in a covered transaction may rely upon a certification of a prospective participant in a lower tier covered transaction that it is not debarred, suspended, ineligible, or voluntarily excluded from the covered transaction, unless it knows that the certification is erroneous. A participant may decide the method and frequency by which it determines the eligibility of its principals. Each participant may, but is not required to, check the Nonprocurement List issued by U.S. General Service Administration.

8. Nothing contained in the foregoing shall be construed to require establishment of system of records in order to render in good faith the certification required by this clause. The knowledge and information of a participant is not required to exceed that which is normally possessed by a prudent person in the ordinary course of business dealings.

9. Except for transactions authorized under Paragraph 5 of these instructions, if a participant in a covered transaction knowingly enters into a lower tier covered transaction with a person who is suspended, debarred, ineligible, or voluntarily excluded from participation in this transaction, in addition to all remedies available to the Federal Government, MVRTD or parties having used the procurement to order buses may pursue available remedies including suspension and/or debarment.

10. Contractor must complete Attachment 13 and submit it to MVRTD with the bid or proposal.

11. Any Subcontractor whose total payments from the prime contractor, may exceed \$25,000 over the course of this contract, shall also complete Attachment 13. The prime contractor shall be responsible for obtaining this documentation and for submitting it with the bid or proposal.

15. Breaches and Dispute Resolution

Disputes - Disputes arising in the performance of this Contract which are not resolved by agreement of the parties shall be decided in writing by the authorized representative of the party having used the procurement to order buses. This decision shall be final and conclusive unless within [ten (10)] days from the date of receipt of its copy, the Contractor mails or otherwise furnishes a written appeal to the party having used the procurement to order buses. In connection with any such appeal, the Contractor shall be afforded an opportunity to be heard and to offer evidence in support of its position. The decision of the party having used the procurement to order buses shall be binding upon the Contractor and the Contractor shall abide by the decision.

Performance During Dispute - Unless otherwise directed by the party having used the procurement to order buses, Contractor shall continue performance under this Contract while matters in dispute are being resolved.

Claims for Damages - Should either party to the Contract suffer injury or damage to person or property because of any act or omission of the other party or of any of his employees, agents or others for whose acts he is legally liable, a claim for damages therefore shall be made in writing to such other party within a reasonable time after the first observance of such injury or damage.

Remedies - Unless this contract provides otherwise, all claims, counterclaims, disputes and other matters in question between the party having used the procurement to order buses and the Contractor arising out of or relating to this agreement or its breach will be decided in Chittenden Superior Court or the United States District Court for the Vermont District.

16. Disadvantaged Business Enterprises –Revenue Vehicles

4.2 Special Contract Provisions | 2020

Each transit vehicle manufacturer submit with their bid or proposal a TVM certification stating that they have submitted an annual DBE goal to the Federal Transit; and that it has either been approved or that to date it has not been disapproved.

Transit vehicle manufacturer shall also submit with their bid or proposal a print out of the FTA web site showing their firm's listing. Transit vehicle manufacturer shall also submit a current listing with every option order. Transit vehicle manufacturers must comply with 49 CFR Parts 23 and 26 in order to be eligible to bid or propose.

The Contractor agrees to pay each subcontractor under this prime contract for satisfactory performance of its contract no later than 15 days from the receipt of each payment the Contractor receives from the party having used the procurement to order buses. The Contractor agrees further to return retainage payments to each subcontractor within 30 days after the subcontractor's work is satisfactorily completed. Any delay or postponement of payment from the above referenced time frame may occur only for good cause following written approval of the party having used the procurement to order buses. This clause applies to both DBE and non-DBE subcontractors.

Sanctions/consequences of noncompliance with the prompt payment clause may include:

- a. Requiring documentation of all payment to subcontractors for all previous payments from the party having used the procurement to order buses to the Contractor before any future payments from the party having used the procurement to order buses to the Contractor are made.
- b. Termination of contract for Default
- c. Inability of Contractor to bid on any future procurements issued by MVRTD or the party having used the procurement to order buses.

The party having used the procurement to order buses will ensure that the prompt payment clause of the contract is enforced by:

1. Requiring Contractors (in sub-contracts in excess of \$10,000) to provide subcontractors with all contract provisions, including the prompt payment provision to ensure that subcontractors are knowledgeable of the prompt payment requirement.
2. Because our contract requires prompt payment by the prime to the sub, the sub is entitled to prompt payment. Because subcontractors will be aware of this right, and it is in their greatest financial interest to assure that this right is respected, we believe it is reasonable to expect that subcontractors not receiving prompt payment will contact the party having used the procurement to order buses.
3. If the party having used the procurement to order buses is contacted by a subcontractor regarding possible violation of the prompt payment clause by the Contractor, we will make inquiries to the Contractor. Depending on the response from the Contractor, the party having used the procurement to order buses may implement the sanctions/consequences listed in the above section.

17. Equal Employment Opportunity for Non-Construction Contracts

The contractor agrees to comply with all requirements of Title VII of the Civil Rights Act of 1964, as amended, 42 U.S.C. § 2000e, and 49 U.S.C. § 5332 and any implementing requirements FTA may issue. Those equal employment opportunity (EEO) requirements include, but are not limited to, the following:

The Contractor agrees that it will not discriminate against any employee or applicant for employment because of race, color, creed, sex, disability, age, or national origin. The Recipient agrees to take affirmative action to ensure that applicants are employed and that employees

are treated during employment, without regard to their race, color, creed, sex, disability, age, or national origin. Such action shall include, but not be limited to, employment, upgrading, demotion or transfer, recruitment or recruitment advertising, layoff or termination; rates of pay or other forms of compensation; and selection for training, including apprenticeship. The Contractor also agrees to comply with any implementing requirements FTA may issue.

The contractor will also insert this provision in all its sub-contracts.

18. Notification of Federal Participation

This contract is funded in part with funding from the United States Department of Transportation Federal Transit Administration (FTA). Eighty percent of the funding of this project is from the FTA.

19. Subcontracting and Assignability

Contractor shall not assign, sublet, pledge or transfer its rights under this Agreement, in whole or in part, nor delegate or subcontract any of its duties or obligations under this Agreement nor grant any licenses or concessions hereunder, without the prior written approval of the senior staff member of the party having used the procurement to order buses. Such approval may be withheld at the sole discretion of the party having used the procurement to order buses. Contractor shall advise the party having used the procurement to order buses before entering into any subcontract in relation to this contract and shall not enter into any subcontract to which the party having used the procurement to order buses has made timely objection. All subcontracts shall be in writing and each subcontractor shall, to the extent of the work or services to be performed by the subcontractor, assume toward the contractor all of the obligations and responsibilities that the contractor, by this contract, assumes toward the party having used the procurement to order buses. As used in this contract, the term "contractor" shall mean the contractor and any of its subcontractors. Nothing in this contract shall be deemed to establish a contractual relationship between a subcontractor and the party having used the procurement to order buses.

20. Approved Equals

In all cases, products must be furnished as specified, but where brand names are used, consider the term "approved equal" to follow. The discretion to approve equal substitutions rests solely with MVRTD. It is the responsibility of the bidder to furnish sufficient technical detail to support its position that substitutions are equal.

Requests for approved equals, clarification of specifications and protest of specifications must be received by MVRTD c/o VEIC, in writing, as per the procurement schedule in Section I "General Terms". Any request for an approved equal or protest of the specifications must be fully supported with all necessary technical data, test results, or other pertinent information. The bidder must demonstrate the equality of his product to MVRTD in order that MVRTD may determine whether the supplier's product is or is not equal to that specified. Parties dissatisfied with the decision of MVRTD may utilize the appeal procedure set forth in MVRTD's appeals clause.

"Request for Approved Equal" form is included as Attachment 18.

21. Additional Contractor's Insurance Requirements

- a. The Contractor shall obtain, maintain, and pay the premiums for insurance policies of the types and in the limits of not less than the following:

1) (a) Worker's Compensation and (b) Employer's Liability Insurance, which shall cover all the Contractor's Employees engaged in the performance of the work.

Worker's compensation shall be provided for all employees of the company, including owners, even if under State law owners are exempt from such insurance requirements. However, owners who have received an approved To Exclude Corporate Officers from Workers' Compensation Coverage, Form 29 and who submit it with their proposal to MVRTD or the party having used the procurement to order buses are exempted from providing the coverage that the form approved. The party having used the procurement to order buses acknowledges that there are other methods for excluding owners from Workers' compensation, but has elected NOT to accept any other method.

2) Comprehensive General Liability Insurance Coverage with limits not less than required by the Umbrella Liability Insurance below and covering at least:

- (a) Operations – Premised Liability
- (b) Independent Contractor's Liability
- (c) Broad Form Contractor's Liability covering the Contractor's obligations
- (d) Personal Injury Liability including claims arising from employees of the Contractor
- (e) Broad Form Property Damage Liability
- (f) Product Liability Insurance (if providing goods or services)
- (g) Errors & Omissions Insurance - Design Liability
- (h) Comprehensive General Liability (including bodily injury and death)

3) Comprehensive Automobile Insurance including property and liability coverage for all owned, hired, and non-owned vehicles with limits not less than One Million Dollars (\$1,000,000) Combined single limit.

4) Policy limits required for each line of coverage listed above in 1, 2 and 3 are \$1,000,000. the party having used the procurement to order buses will accept underlying line coverage, underlying with excess, or underlying with umbrella so long that the total (including umbrella or excess) for each line of coverage totals at least \$1,000,000.

5) Property insurance on a replacement cost basis of any real property owned by contractor and used in connection with this contract.

6) Professional Error & Omission coverage with a minimum limit of \$1,000,000 and a maximum deductible of \$5,000.

7) Contractor shall also obtain and maintain other policies of insurance of the types and limits that Contractor deems sufficient for its own protection.

- b. All Such insurance as indicated above shall be provided by insurance companies having a Best's rating of not less than A:XII, as shown in the current issue of Best's Key Rating Guide, Property-Casualty.
- c. Proof that such insurance coverage exists shall be furnished to the party having used the procurement to order buses in the form of certificates from the insurance companies before the Contractor commences any portion of the contracted work.

The party having used the procurement to order buses shall be endorsed as an additional insured under such policies with the exceptions of Contractor's workers compensation policy and professional liability (if applicable).

Such certificates and/or endorsements shall provide that 15 days' notice in writing shall be given to the party having used the procurement to order buses prior to any change or

cancellation of underlying policies due to non-payment of premium, and 45 days notice in writing shall be given to the party having used the procurement to order buses prior to any change or cancellation of underlying policies due to non-renewal.

- d. The Contractor and all of its insurers shall waive all rights of recovery or subrogation against the party having used the procurement to order buses and its insurance companies.
- e. The Contractor shall be responsible for compliance with all safety rules and regulations of the Federal Occupational Safety and Health Act of 1970 and those of all applicable State Acts, Laws, or Regulations during the conduct of the Contractor's performance of this Contract. The Contractor shall indemnify, defend and hold the party having used the procurement to order buses harmless from any fines, penalties, and corrective measures that result from the acts of commission or omission of the Contractor, its subcontractors, if any, and the contractor's and/or subcontractor's agents, employees and assigns for their failure to comply with such safety rules and regulations.
- f. The party having used the procurement to order buses will give to the Contractor prompt notice in writing of the institution of any suit or proceeding and permit the Contractor to defend the same, and will give all needed information, assistance, and authority to enable the Contractor to do so. The Contractor shall similarly give the party having used the procurement to order buses immediate notice of any suit or action filed or prompt notice of any claim arising out of the performance of the Contract. The Contractor shall furnish immediately to the party having used the procurement to order buses copies of all pertinent papers received by the Contractor.
- g. The Contractor shall require its subcontractors, if any, to obtain an amount of insurance coverage which is deemed adequate by the Contractor.
- h. The party having used the procurement to order buses reserves the right to inspect, in person, prior to commencement of the work, all of the Contractor's insurance policies in regard to insurance required herein.

22. Award Based on Initial Proposals

Awards to proposers may be made, at MVRTD's sole discretion, without discussion of proposals with proposers. Proposals should be submitted initially on the most favorable terms possible, from a price and technical standpoint.

23. Metric System.

The contractor understands that the Federal government, the USDOT or the FTA may issue guidelines, policies, or regulations requiring metric measurements in this project as may be required by 15 USC 205a (The Metric Conversion Act of 1975) and or Executive order 12770. The party having used the procurement to order buses may, to the extent it deems practicable and feasible, agree to accept products and services with dimensions expressed in the metric system.

24. Air Pollution

The successful bidder agrees to submit certification to MVRTD that the air pollution regulations in the service area of the party having used the procurement to order buses will be met with the proposed vehicles along with other information required for the pre-award audit. Detailed tests results will accompany this certification to evidence that the air pollution criteria have been met. The party having used the procurement to order buses will retain this certification and evidence.

25. Compliance with the Americans with Disabilities Act

The vehicle(s) proposed must meet all applicable federal laws related to accessibility by persons with disabilities including those described in 49 CFR Part 38.

A certification, (Attachment 14) indicating that the federal requirements are fully met must be signed and submitted with the bid.

26. Liabilities against the Party Having Used the Procurement to Order Buses

The Contractor agrees to indemnify, defend and hold the party having used the procurement to order buses harmless from any and all claims and lawsuits by third parties (including, but not limited to, employees and agents of the party having used the procurement to order buses and the Contractor), including the payment of all damages, expenses, penalties, fines, costs, royalties, charges and attorneys' fees incurred by the party having used the procurement to order buses which arise out of, or relate to Contractor's performance of the work required under this contract, whether concerning personal injury (or death), damage to property, or any other type of loss or claim, whether these claims or lawsuits are based upon negligence, intentional misconduct, breach of warranty, strict liability in tort, any failure by the contractor to comply with any laws pertaining to the contract documents, the use of patent appliances, products or processes, use of copyrighted materials, or any breach by the contractor of any of its other duties, representations, covenants, or the agreements in the contract documents. The Contractor will defend all suits brought upon all such claims and lawsuits and will pay all costs and expenses incidental thereto, but the party having used the procurement to order buses shall have the right, at its option, to participate in the defense of any suit, without relieving the Contractor of any of its obligations hereunder.

27. Order of Precedence - Proposal

In the event of inconsistency between provisions of this solicitation prior to the parties entering into a contract, the inconsistency will be resolved by giving precedence in the following order: 1) the MVRTD project completion timeline for performance as set forth in the solicitation (if any); 2) solicitation instructions and technical specifications, if included; 3) MVRTD General Contract Provisions and MVRTD Special Contract Provisions, which are included in the solicitation documents; and 4) in the event of any inconsistencies between the technical specifications and a written request for approval that has been approved by MVRTD, the request for approval will have precedence.

28. Order of Precedence – Contract

In the event of inconsistency between various documents that constitute the contract, the inconsistency will be resolved by giving precedence in the following order: 1) any modifications approved by the party having used the procurement to order buses after the contract was signed; 2) any contract documents the party having used the procurement to order buses executes to award the contract (such as a purchase order, letter of contract award, or negotiated contract signed by both parties); 3) the Contractor's proposal including any approved equals or modifications approved by MVRTD; and 4) the solicitation.

29. Use of the Name of the Party Having Used the Procurement to Order Buses in Contractor Advertising or Public Relations

The Contractor will not allow the logo(s) of the party having used the procurement to order buses or any of said party's related copy to be published in the Contractor's advertisements or public relations programs without said party's written approval and then only upon submitting such material to said party for review. The Contractor will agree that published information on said party or its services will be factual and in no way imply that MVRTD and/or said party endorsed the Contractor's firm, service, or product.

30. Protest procedures.

Any bidder wishing to protest prior to or after the award of a contract must follow MVRTD's protest procedures contained below. Deadlines in protest procedures must be adhered to otherwise MVRTD will not consider the protest. In addition, the protest must include a statement that that it is a protest, otherwise it will not be considered a protest.

Protest Procedures

Protests concerning CCTA's purchasing policies, the contract requirements, the specifications, the bidding procedures, or the contract award, or any other request for explanation or clarification must be submitted in writing and must include the following information.¹

- a. The name and address of the protester.
- b. The name and telephone number of the protester's contact person having responsibility.
- c. A complete statement of the grounds of the protest with full documentation of the protester's claim.

a. Pre-award Protests

Pre-award protests must be received by MVRTD no less than ten (10) working days before the scheduled bid opening. MVRTD will respond to the protest in writing and render its final decision at least five (5) working days prior to bid opening. MVRTD will report such protests to the FTA regional office.

b. Post-award Protests

Post-award protests will be received no later than five (5) working days after notification of the award bid. MVRTD will have ten (10) working days after receipt of the formal protest package to evaluate, and issue a response, except in cases where the original bid has been awarded by the Board. In such cases, the decision to protest will be handled at the next regularly scheduled Board meeting, following completion of the staff review of the protests. MVRTD will report such protests to the FTA regional office.

c. Appeals to FTA

It is the responsibility of MVRTD to settle contract issues and disputes. MVRTD is committed to using good sound administrative practices and business judgments, as well as professional ethics. Reviews of protests by FTA will be limited to alleged failure by MVRTD to have followed proper protests procedures, or its failure to review a complaint or protest. Protesters dissatisfied with MVRTD's final decision may appeal to FTA regional or Headquarters Office within five (5) working days of the date the protester knew or should have known of the violation.²

31. Addenda Acknowledgement

The bidder must submit with the Bid an Addenda Acknowledgement Form acknowledging receipt of all bid addenda issued by MVRTD. Acknowledge receipt of addenda on Attachment 15.

32. Terms of Payment

The entity having used this procurement to order buses shall make payment to the Contractor within 15 working days after acceptance of each vehicle. The entity having used this procurement to order buses reserves the right to withhold full payment as outlined in the provisions contained within the section entitled Conditional Acceptance. The Contractor's invoice

¹ U.S. DOT FTA Circular 4220.1D § 7I

² U.S. DOT FTA Circular 4220.1D § 7k and 7I

for the vehicles, and/or spare parts, and/or equipment, and/or optional warranties will be submitted to the entity having used this procurement to order buses within 30 days prior to the scheduled delivery of the vehicles.

An invoice shall be submitted for each vehicle. Each invoice must include the following:

- Contract Number
- Serial Number of Vehicle
- Procuring Agency Fleet Number of Vehicle
- Serial Number of the Engine
- Serial Number of Transmission
- Cost of Optional Warranties
- Total Invoice Amount

The entity must have a Certificate of Origin from the Contractor at least fifteen (15) calendar days prior to shipment.

Documents for securing the vehicle title and registration in the State of Vermont shall be provided to the entity having used this procurement to order buses prior to release of payment for vehicles. The Contractor warrants that the title shall pass to the entity having used this procurement to order buses free and clear of all liens, mortgages and encumbrances, financing statements, security agreements, claims and demands of any character.

33. Bidders Checklist

Bidders must fill out the bidder's checklist in Attachment 16.

34. ITS Compliance

To the extent applicable, the Contractor agrees to conform to the National Intelligent Transportation Systems (ITS) Architecture and Standards as required by SAFETEA LU § 5307(c), 23 U.S.C. § 512 note, and comply with FTA Notice, "FTA National ITS Architecture Policy on Transit Projects" 66 Fed. Reg. 1455 et seq., January 8, 2001, and any subsequent further implementing directives, except to the extent FTA determines otherwise in writing.

35. ISO Certification

The manufacturer of the buses shall have a proven third-party certified quality control system in place and shall be ISO 9001:2000 certified at the facility that will produce the buses as bid.

Bidder must fill out Manufacturer's Certification (Attachment 17) certifying that they are ISO 9001 compliant.

Attachment 3

**BUY AMERICA CERTIFICATE OF COMPLIANCE WITH FTA REQUIREMENTS
FOR BUSES, OTHER ROLLING STOCK, OR ASSOCIATED EQUIPMENT**

Certificate of Compliance With Section 165(b)(3)

The bidder or offeror hereby certifies that it will comply with the requirements of section 165(b)(3), of the Surface Transportation Assistance Act of 1982, as amended, and the regulations of 49 USC 5323(j) and 49 CFR 661.11, as amended by Section 3011 of the FAST Act.

Date _____

Signature _____

Company Name _____

Title _____

Certificate for Non-Compliance with Section 165(b)(3)

The bidder or offeror hereby certifies that it cannot comply with the requirements of section 165(b)(3) of the Surface Transportation Assistance Act of 1982, as amended, but may qualify for an exception to the requirement consistent with section 165(b)(2) or (b)(4) of the Surface Transportation Assistance Act, as amended, and regulations in 49 USC 5323(j) and 49 CFR 661.7, as amended by Section 3011 of the FAST Act.

Date _____

Signature _____

Company _____

Name _____

Title _____

Attachment 4

BID BOND

KNOW ALL MEN BY THESE PRESENTS, that we, the undersigned, _____
_____ as PRINCIPAL, and _____ as Surety, are hereby held
and firmly bound unto Marble Valley Regional Transit District (MVRTD) as OWNER in the
penal sum of
_____ for the payment of which, well and truly to be made, we hereby
jointly and severally bind ourselves, successor and assigns.

Signed, this _____ day of _____, 20__.

The Condition of the above obligation is such that whereas the PRINCIPAL has submitted to
MVRTD a certain Bid, attached hereto and hereby made a part hereof to enter into a
contract in writing, for the

(Name of Project)

NOW, THEREFORE,

- (a) If said BID shall be rejected, or in the alternate,
- (b) If said BID shall be accepted and the PRINCIPAL shall execute and deliver a
contract in the Form of Contract attached hereto (properly completed in accordance
with said BID) and shall furnish a bond for his faithful performance of said contract,
and for the payment of all persons performing labor or furnishing materials in
connection therewith, and shall in all other respects perform the agreement created
by the acceptance of said BID, then this obligation shall be void, otherwise the same
shall remain in force and effect; it being expressly understood and agreed that the
liability of the Surety for any and all claims hereunder shall, in no event, exceed the
penal amount of this obligation herein stated.

Attachment 4 (continued)

BID BOND (continued)

The Surety, for value received, hereby stipulates and agrees that the obligations of said Surety and its bond shall be in no way impaired or affected by any extension of the time within which the OWNER may accept such Bid; and said Surety does hereby waive notice of any such extension.

IN WITNESS WHEREOF, the PRINCIPAL and the Surety have hereunto set their hands and seals, and such of them as are corporations have caused their corporate seals to be hereto affixed and these presents to be signed by their proper offices, the day and year first set forth above.

Principal

Surety

By: _____

IMPORTANT: Surety companies executing bonds must appear on the Treasury Department's most current list (Circular 570 as amended) and be authorized to transact in business in the State of Vermont where the project is located.

Attachment 8

CERTIFICATION OF COMPLIANCE WITH FTA'S BUS TESTING REQUIREMENTS

The undersigned [Contractor/Manufacturer] certifies that the vehicle offered in this procurement complies with 49 U.S.C. A 5323(c) and FTA's implementing regulation at 49 CFR Part 665.

The undersigned understands that misrepresenting the testing status of a vehicle acquired with Federal financial assistance may subject the undersigned to civil penalties as outlined in the Department of Transportation's regulation on Program Fraud Civil Remedies, 49 CFR Part 31. In addition, the undersigned understands that FTA may suspend or debar a manufacturer under the procedures in 49 CFR Part 29.

Date: _____

Signature: _____

Company Name: _____

Title: _____

Attachment 9

Pre-Award FMVSS Certification

As required by 49 CFR 663, _____

certifies that our _____ model bus, as proposed for delivery to MVRTD, complies with the relevant Federal Motor Vehicle Safety Standards issued by the National Highway Traffic Safety Administration in 49 CFR, Part 571.

Date _____

Signature _____

Company Name _____

Title _____

Attachment 10

Post Delivery FMVSS Certification

As required by 49 CFR 663, _____
certifies that our _____ model bus, as delivered to MVRTD
complies with the relevant Federal Motor Vehicle Safety Standards issued by the National highway
Traffic Safety Administration in 49 CFR, Part 571.

Date _____

Signature _____

Company Name _____

Title _____

Attachment 11

Lobbying Certification

The undersigned [Contractor] certifies, to the best of his or her knowledge and belief, that:

(1) No Federal appropriated funds have been paid or will be paid, by or on behalf of the undersigned, to any person for influencing or attempting to influence an officer or employee of an agency, a Member of Congress, an officer or employee of Congress, or an employee of a Member of Congress in connection with the awarding of any Federal contract, the making of any Federal grant, the making of any Federal loan, the entering into of any cooperative agreement, and the extension, continuation, renewal, amendment, or modification of any Federal contract, grant, loan, or cooperative agreement.

(2) If any funds other than Federal appropriated funds have been paid or will be paid to any person for making lobbying contacts to an officer or employee of any agency, a Member of Congress, an officer or employee of Congress, or an employee of a Member of Congress in connection with this Federal contract, grant, loan, or cooperative agreement, the undersigned shall complete and submit Standard Form-- LLL, "Disclosure Form to Report Lobbying," in accordance with its instructions [as amended by "Government wide Guidance for New Restrictions on Lobbying," 61 Fed. Reg. 1413 (1/19/96). Note: Language in paragraph (2) herein has been modified in accordance with Section 10 of the Lobbying Disclosure Act of 1995 (P.L. 104-65, to be codified at 2 U.S.C. 1601, et seq.)]

(3) The undersigned shall require that the language of this certification be included in the award documents for all subawards at all tiers (including subcontracts, subgrants, and contracts under grants, loans, and cooperative agreements) and that all subrecipients shall certify and disclose accordingly.

This certification is a material representation of fact upon which reliance was placed when this transaction was made or entered into. Submission of this certification is a prerequisite for making or entering into this transaction imposed by 31, U.S.C. § 1352 (as amended by the Lobbying Disclosure Act of 1995). Any person who fails to file the required certification shall be subject to a civil penalty of not less than \$10,000 and not more than \$100,000 for each such failure.

[Note: Pursuant to 31 U.S.C. § 1352(c)(1)-(2)(A), any person who makes a prohibited expenditure or fails to file or amend a required certification or disclosure form shall be subject to a civil penalty of not less than \$10,000 and not more than \$100,000 for each such expenditure or failure.]

The Contractor, _____, certifies or affirms the truthfulness and accuracy of each statement of its certification and disclosure, if any. In addition, the Contractor understands and agrees that the provisions of 31 U.S.C. A 3801, et seq., apply to this certification and disclosure, if any.

_____ Signature of Contractor's Authorized Official

_____ Name and Title of Contractor's Authorized Official

_____ Date

Attachment 13

**Certification Regarding Debarment, Suspension, and Other Responsibility Matters--
Covered Transactions**

This form shall be completed by the prospective prime contractors AND prospective subcontractors, whose contract amount MAY exceed \$25,000 over the life of the contract.

(1) The prospective lower tier participant (potential contractor or subcontractor) _____ certifies to the best of its knowledge and belief, that it and its principals:

- (a) Are not presently debarred, suspended, proposed for debarment, declared ineligible, or voluntarily excluded by any Federal department or agency;
- (b) Have not within a three-year period preceding this proposal been convicted of or had a civil judgment rendered against them for commission of fraud or a criminal offense in connection with obtaining, attempting to obtain, or performing a public (Federal, State or local) transaction or contract under a public transaction; violation of Federal or State antitrust statutes or commission of embezzlement, theft, forgery, bribery, falsification or destruction of records, making false statements, or receiving stolen property;
- (c) Are not presently indicted for or otherwise criminally or civilly charged by a governmental entity (Federal, State or local) with commission of any of the offenses enumerated in paragraph (1)(b) of this certification; and
- (d) Have not within a three-year period preceding this application/proposal had one or more public transactions (Federal, State or local) terminated for cause or default.

(2) Where the prospective lower tier participant is unable to certify to any of the statements in this certification, such prospective participant shall attach an explanation to this proposal.

The prospective lower tier participant (potential contractor or subcontractor) _____ certifies or affirms the truthfulness and accuracy of the contents of the statements submitted on or with this certification.

_____ Signature of Contractor's Authorized Official

_____ Name and Title of Contractor's Authorized Official

_____ Date

Attachment 14

Certification Regarding Compliance with the Americans with Disabilities Act for Revenue Vehicles

_____ certifies that all vehicles manufactured and delivered to MVRTD will be in full compliance with the Americans with Disabilities Act.

_____ Signature of Contractor's Authorized Official

_____ Name and Title of Contractor's Authorized Official

_____ Date

Attachment 15

Addenda Acknowledgement Form

Addenda received

Addendum No: _____ **Date Received:** _____

Addendum No: _____ **Date Received:** _____

Addendum No: _____ **Date Received:** _____

Addendum No: _____ **Date Received:** _____

Addendum No: _____ **Date Received:** _____

Addendum No: _____ **Date Received:** _____

Addendum No: _____ **Date Received:** _____

Addendum No: _____ **Date Received:** _____

_____ Signature of Contractor's Authorized Official

_____ Name and Title of Contractor's Authorized Official

_____ Date

Attachment 16

Bidders Checklist

This form must be completed and returned with the submission of bid documents. The bidder must use this checklist to help ensure all required certifications, affidavits, and documentation are provided. If the referenced attachment is not required, the bidder must right "N/A" in the check off space.

Description of Attached Documents	Bidder Check Off	MVRTD Check off
Attachment A (4.1 General Contract Provisions): Affidavit of Non-Collusion	_____	_____
Attachment B (4.1 General Contract Provisions): Firm Information for MVRTD's Bidders List	_____	_____
Attachments 1-2: [Intentionally Omitted]	_____	_____
Attachment 3: Buy America Certification for rolling stock and relate purchases.	_____	_____
Attachment 4: Bid Bond or Proposal Guarantee or Irrevocable letter of Credit	_____	_____
Attachments 5-7: [Intentionally Omitted]	_____	_____
Attachment 8: Compliance with FTA's Bus Testing Requirements	_____	_____
Altoona Bus Testing Report(s)	_____	_____
Attachment 9: Pre-Award FMVSS Certification	_____	_____
Attachment 10: Post Delivery FMVSS Certification	_____	_____
Attachment 11: Lobbying Certification	_____	_____
Attachment 12: [Intentionally Omitted]	_____	_____
Attachment 13: Debarment, Suspension, and Other Responsibility Matters	_____	_____
Attachment 14: Compliance with the Americans with Disabilities Act for Revenue Vehicles	_____	_____
Attachment 15: Addenda Acknowledgement Form	_____	_____
Attachment 16: Bidder's Checklist	_____	_____
Attachment 17: Manufacturer's Certification	_____	_____
Attachment 18: Approved Equals Request Form	_____	_____
DBE TVM Certificate of Compliance	_____	_____
TVM Printout from FTA Web Site for Current Year	_____	_____

_____ Signature of Contractor's Authorized Official

_____ Name and Title of Contractor's Authorized Official

_____ Date

Attachment 17

Manufacturer's Certification

The _____ hereby certifies that the offered has been designed, manufactured, assembled, tested, and found suitable for the intended purpose as specified in the Bid Documents including ISO 9001 certification (and any revision thereof).

_____ Signature of Contractor's Authorized Official

_____ Name and Title of Contractor's Authorized Official

_____ Date

Attachment 18

REQUEST FOR APPROVED EQUAL

This form must be used for requested clarifications, changes, substitutes or approval of items equal to items specified with a brand name, and must be submitted as far in advance of the Due Date as specified in the RFP.

Request #: _____	Offeror: _____
Solicitation Ref: _____	Page: _____ Section: _____
Questions/Clarification or Approved Equal: _____	
Purchasing Group: _____	

Approved (Initials/date) _____ Not Approved Initials/date _____

4.3 Other Federal Requirements | 2020

Full and Open Competition - In accordance with 49 U.S.C. § 5325(h) all procurement transactions shall be conducted in a manner that provides full and open competition.

Prohibition Against Exclusionary or Discriminatory Specifications - Apart from inconsistent requirements imposed by Federal statute or regulations, the contractor shall comply with the requirements of 49 USC 5323(h)(2) by refraining from using any FTA assistance to support procurements using exclusionary or discriminatory specifications.

Conformance with ITS National Architecture - Contractor shall conform, to the extent applicable, to the National Intelligent Transportation Standards architecture as required by SAFETEA-LU Section 5307(c), 23 U.S.C. Section 512 note and follow the provisions of FTA Notice, "FTA National Architecture Policy on Transit Projects," 66 Fed. Reg. 1455 et seq., January 8, 2001, and any other implementing directives FTA may issue at a later date, except to the extent FTA determines otherwise in writing.

Access Requirements for Persons with Disabilities - Contractor shall comply with 49 USC 5301(d), stating Federal policy that the elderly and persons with disabilities have the same rights as other persons to use mass transportation services and facilities and that special efforts shall be made in planning and designing those services and facilities to implement that policy. Contractor shall also comply with all applicable requirements of Sec. 504 of the Rehabilitation Act (1973), as amended, 29 USC 794, which prohibits discrimination on the basis of handicaps, and the Americans with Disabilities Act of 1990 (ADA), as amended, 42 USC 12101 et seq., which requires that accessible facilities and services be made available to persons with disabilities, including any subsequent amendments thereto.

Notification of Federal Participation - To the extent required by law, in the announcement of any third party contract award for goods and services (including construction services) having an aggregate value of \$500,000 or more, contractor shall specify the amount of Federal assistance to be used in financing that acquisition of goods and services and to express that amount of Federal assistance as a percentage of the total cost of the third party contract.

Interest of Members or Delegates to Congress - No members of, or delegates to, the US Congress shall be admitted to any share or part of this contract nor to any benefit arising therefrom.

Ineligible Contractors and Subcontractors - Any name appearing upon the Comptroller General's list of ineligible contractors for federally- assisted contracts shall be ineligible to act as a subcontractor for contractor pursuant to this contract. If contractor is on the Comptroller General's list of ineligible contractors for federally financed or assisted construction, the recipient shall cancel, terminate or suspend this contract.

Other Contract Requirements - To the extent not inconsistent with the foregoing Federal requirements, this contract shall also include those standard clauses attached hereto, and shall comply with the recipient's Procurement Guidelines, available upon request from the recipient.

Compliance With Federal Regulations - Any contract entered pursuant to this solicitation shall contain the following provisions: All USDOT- required contractual provisions, as set forth in FTA Circular 4220.1F, are incorporated by reference. Anything to the contrary herein notwithstanding, FTA mandated terms shall control in the event of a conflict with other provisions contained in this Agreement. Contractor shall not perform any act, fail to perform any act, or refuse to comply with any grantee request that would cause the recipient to be in violation of FTA terms and conditions. Contractor shall comply with all applicable FTA regulations, policies, procedures and directives, including, without limitation, those listed directly or incorporated by reference in the Master Agreement between the recipient and FTA, as may be amended or promulgated from time to time during the term of this contract. Contractor's failure to so comply shall constitute a material breach of this contract.

4.3 Other Federal Requirements | 2020

Real Property - Any contract entered into shall contain the following provisions: Contractor shall at all times comply with all applicable statutes and USDOT regulations, policies, procedures and directives governing the acquisition, use and disposal of real property, including, but not limited to, 49 CFR 18.31-18.34, 49 CFR 19.30-19.37, 49 CFR Part 24, 49 CFR 5326 as amended by Map-21, 49 CFR part 18 or 19, 49 USC 5334, applicable FTA Circular 5010, and FTA Master Agreement, as they may be amended or promulgated during the term of this contract. Contractor's failure to so comply shall constitute a material breach of this contract.

Access to Services for Persons with Limited English Proficiency - To the extent applicable and except to the extent that FTA determines otherwise in writing, the Recipient agrees to comply with the policies of Executive Order No. 13166, "Improving Access to Services for Persons with Limited English Proficiency," 42 U.S.C. § 2000d 1 note, and with the provisions of U.S. DOT Notice, "DOT Guidance to Recipients on Special Language Services to Limited English Proficient (LEP) Beneficiaries," 70 Fed. Reg. 74087, December 14, 2005.

Environmental Justice - Except as the Federal Government determines otherwise in writing, the Recipient agrees to promote environmental justice by following: (1) Executive Order No. 12898, "Federal Actions to Address Environmental Justice in Minority Populations and Low-Income Populations," February 11, 1994, 42 U.S.C. § 4321 note, as well as facilitating compliance with that Executive Order, and (2) DOT Order 5610.2, "Department of Transportation Actions To Address Environmental Justice in Minority Populations and Low-Income Populations," 62 Fed. Reg. 18377, April 15, 1997, and (3) The most recent and applicable edition of FTA Circular 4703.1, "Environmental Justice Policy Guidance for Federal Transit Administration Recipients," August 15, 2012, to the extent consistent with applicable Federal laws, regulations, and guidance.

Environmental Protections - Compliance is required with any applicable Federal laws imposing environmental and resource conservation requirements for the project. Some, but not all, of the major Federal laws that may affect the project include: the National Environmental Policy Act of 1969; the Clean Air Act; the Resource Conservation and Recovery Act; the comprehensive Environmental response, Compensation and Liability Act; as well as environmental provisions with Title 23 U.S.C., and 49 U.C. chapter 53. The U.S. EPA, FHWA and other federal agencies may issue other federal regulations and directives that may affect the project. Compliance is required with any applicable Federal laws and regulations in effect now or that become effective in the future.

Geographic Information and Related Spatial Data - (NOT APPLICABLE TO THE TRIBAL TRANSIT PROGRAM) Any project activities involving spatial data or geographic information systems activities financed with Federal assistance are required to be consistent with the National Spatial Data Infrastructure promulgated by the Federal Geographic Data Committee, except to the extent that FTA determines otherwise in writing.

Geographic Preference - All project activities must be advertised without geographic preference, (except in A/E under certain circumstances, preference for hiring veterans on transit construction projects and geographic-based hiring preferences as proposes to be amended in 2 CFR Part 1201).

Federal Single Audit Requirements - For State Administered Federally Aid Funded Projects Only Non Federal entities that expend \$750,000 or more in a year in Federal awards from all sources are required to comply with the Federal Single Audit Act provisions contained in U.S. Office of Management and Budget (OMB) Circular No. A 133, "Audits of States, Local Governments, and Non Profit Organizations" (replaced with 2 CFR Part 200, "Uniform Administrative Requirements, Cost Principles, and Audit Requirements for Federal Awards" effective December 26, 2014 as applicable). Non Federal entities that expend Federal awards from a single source may provide a program specific audit, as defined in the Circular. Non Federal entities that expend less than the amount above in a year in Federal awards from all sources are exempt from Federal audit requirements for that year, except as noted in Sec. 215 (a) of OMB Circular A-133 Subpart B--Audits, records must be available for review or audit by appropriate officials of the cognizant Federal agency the New York State Department of Transportation, the New York State Comptrollers Office and the U.S.

4.3 Other Federal Requirements | 2020

Governmental Accountability Office (GAO). Non Federal entities are required to submit a copy of all audits, as described above, within 30 days of issuance of audit report, but no later than 9 months after the end of the entity's fiscal year, to the New York State Department of Transportation, Contract Audit Bureau, 50 Wolf Road, Albany, NY 12232. Unless a time extension has been granted by the cognizant Federal Agency and has been filed with the New York State Department of Transportation's Contract Audit Bureau, failure to comply with the requirements of OMB Circular A-133 may result in suspension or termination of Federal award payments. Catalog of Federal Domestic Assistance (CFDA) Identification Number The municipal project sponsor is required to identify in its accounts all Federal awards received and expended, and the Federal programs under which they were received. Federal program and award identification shall include, as applicable, the CFDA title and number, award number and year, name of the Federal agency, and name of the pass through entity.

Veterans Preference - As provided by 49 U.S.C. 5325(k), to the extent practicable, the Recipient agrees and assures that each of its Subrecipients:

(1) Will give a hiring preference to veterans, as defined in 5 U.S.C. § 2108, who have the skills and abilities required to perform construction work required under a third party contract in connection with a Capital Project supported with federal assistance appropriated or made available for 49 U.S.C. chapter 53, and (2) Will not require an employer to give a preference to any veteran over any equally qualified applicant who is a member of any racial or ethnic minority, female, an individual with a disability, or a former employee.

Safe Operation of Motor Vehicles

a. Seat Belt Use. The Recipient agrees to implement Executive Order No. 13043, "Increasing Seat Belt Use in the United States," April 16, 1997, 23 U.S.C. § 402 note, (62 Fed. Reg. 19217), by: (1) Adopting and promoting on-the-job seat belt use policies and programs for its employees and other personnel that operate company-owned vehicles, company-rented vehicles, or personally operated vehicles, and (2) Including a "Seat Belt Use" provision in each third party agreement related to the Award. b. Distracted Driving, Including Text Messaging While Driving. The Recipient agrees to comply with: (1) Executive Order No. 13513, "Federal Leadership on Reducing Text Messaging While Driving," October 1, 2009, 23 U.S.C. § 402 note, (74 Fed. Reg. 51225), (2) U.S. DOT Order 3902.10, "Text Messaging While Driving," December 30, 2009, and (3) The following U.S. DOT Special Provision pertaining to Distracted Driving: (a) Safety. The Recipient agrees to adopt and enforce workplace safety policies to decrease crashes caused by distracted drivers, including policies to ban text messaging while using an electronic device supplied by an employer, and driving a vehicle the driver owns or rents, a vehicle Recipient owns, leases, or rents, or a privately-owned vehicle when on official business in connection with the Award, or when performing any work for or on behalf of the Award, (b) Recipient Size. The Recipient agrees to conduct workplace safety initiatives in a manner commensurate with its size, such as establishing new rules and programs to prohibit text messaging while driving, re-evaluating the existing programs to prohibit text messaging while driving, and providing education, awareness, and other outreach to employees about the safety risks associated with texting while driving, and (c) Extension of Provision. The Recipient agrees to include the preceding Special Provision of section 34.b(3)(a) – (b) of this Master Agreement in its third party agreements, and encourage its Third Party Participants to comply with this Special Provision, and include this Special Provision in each third party subagreement at each tier supported with federal assistance.

Catalog of Federal Domestic Assistance (CFDA) Identification Number - The municipal project sponsor is required to identify in its accounts all Federal awards received and expended, and the Federal programs under which they were received. Federal program and award identification shall include, as applicable, the CFDA title and number, award number and year, name of the Federal agency, and name of the pass through entity.

The CFDA number for the Federal Transit Administration - Nonurbanized Area Formula (Section 5311) is 20.509. A Recipient covered by the Single Audit Act Amendments of 1996 and

4.3 Other Federal Requirements | 2020

OMB Circular A-133, "Audits of States, Local Governments, and Non-Profit Organizations," (replaced with 2 CFR Part 200, "Uniform Administrative Requirements, Cost Principles, and Audit Requirements for Federal Awards" effective December 26, 2014 as applicable) agrees to separately identify the expenditures for Federal awards under the Recovery Act on the Schedule of Expenditures of Federal Awards (SEFA) and the Data Collection Form (SF-SAC) required by OMB Circular A-133. The Recipient agrees to accomplish this by identifying expenditures for Federal awards made under Recovery Act separately on the SEFA, and as separate rows under Item 9 of Part III on the SF-SAC by CFDA number, and inclusion of the prefix "ARRA" in identifying the name of the Federal program on the SEFA and as the first characters in Item 9d of Part III on the SF-SAC.

Organizational Conflicts of Interest - The Recipient agrees that it will not enter into a procurement that involves a real or apparent organizational conflict of interest described as follows: (1) When It Occurs. An organizational conflict of interest occurs when the Project work, without appropriate restrictions on certain future activities, results in an unfair competitive advantage: (a) To that Third Party Participant or another Third Party Participant performing the Project work, and (b) That impairs that Third Party Participant's objectivity in performing the Project work, or (2) Other. An organizational conflict of interest may involve other situations resulting in fundamentally unfair competitive conditions, (3) Disclosure Requirements.

Consistent with FTA policies, the Recipient must disclose to FTA, and each of its Subrecipients must disclose to the Recipient: (a) Any instances of organizational conflict of interest, or (b) Violations of federal criminal law, involving fraud, bribery, or gratuity violations potentially affecting the federal award, and (4) Failure to Disclose. Failure to make required disclosures can result in remedies for noncompliance, including debarment or suspension.

**ATTACHMENT C: STANDARD STATE PROVISIONS
FOR CONTRACTS AND GRANTS
REVISED DECEMBER 15, 2017**

1. False Claims Act: The Party acknowledges that it is subject to the Vermont False Claims Act as set forth in 32 V.S.A. § 630 *et seq.* If the Party violates the Vermont False Claims Act it shall be liable to the State for civil penalties, treble damages and the costs of the investigation and prosecution of such violation, including attorney's fees, except as the same may be reduced by a court of competent jurisdiction. The Party's liability to the State under the False Claims Act shall not be limited notwithstanding any agreement of the State to otherwise limit Party's liability.

2. Whistleblower Protections: The Party shall not discriminate or retaliate against one of its employees or agents for disclosing information concerning a violation of law, fraud, waste, abuse of authority or acts threatening health or safety, including but not limited to allegations concerning the False Claims Act. Further, the Party shall not require such employees or agents to forego monetary awards as a result of such disclosures, nor should they be required to report misconduct to the Party or its agents prior to reporting to any governmental entity and/or the public.

3. Location of State Data: No State data received, obtained, or generated by the Party in connection with performance under this Agreement shall be processed, transmitted, stored, or transferred by any means outside the continental United States, except with the express written permission of the State.

4. Fair Employment Practices and Americans with Disabilities Act: Party agrees to comply with the requirement of 21 V.S.A. Chapter 5, Subchapter 6, relating to fair employment practices, to the full extent applicable. Party shall also ensure, to the full extent required by the Americans with Disabilities Act of 1990, as amended, that qualified individuals with disabilities receive equitable access to the services, programs, and activities provided by the Party under this Agreement.

5. Taxes Due to the State:

- A. Party understands and acknowledges responsibility, if applicable, for compliance with State tax laws, including income tax withholding for employees performing services within the State, payment of use tax on property used within the State, corporate and/or personal income tax on income earned within the State.
- B. Party certifies under the pains and penalties of perjury that, as of the date this Agreement is signed, the Party is in good standing with respect to, or in full compliance with, a plan to pay any and all taxes due the State of Vermont.
- C. Party understands that final payment under this Agreement may be withheld if the Commissioner of Taxes determines that the Party is not in good standing with respect to or in full compliance with a plan to pay any and all taxes due to the State of Vermont.
- D. Party also understands the State may set off taxes (and related penalties, interest and fees) due to the State of Vermont, but only if the Party has failed to make an appeal within the time allowed by law, or an appeal has been taken and finally determined and the Party has no further legal recourse to contest the amounts due.

6. Child Support: (Only applicable if the Party is a natural person, not a corporation or partnership.) Party states that, as of the date this Agreement is signed, he/she:

- A. is not under any obligation to pay child support; or
- B. is under such an obligation and is in good standing with respect to that obligation; or
- C. has agreed to a payment plan with the Vermont Office of Child Support Services and is in full compliance with that plan.

Party makes this statement with regard to support owed to any and all children residing in Vermont. In addition, if the Party is a resident of Vermont, Party makes this statement with regard to support owed to any and all children residing in any other state or territory of the United States.

7. No Gifts or Gratuities: Party shall not give title or possession of anything of substantial value (including property, currency, travel and/or education programs) to any officer or employee of the State during the term of this Agreement.

8. Certification Regarding Debarment: Party certifies under pains and penalties of perjury that, as of the date that this Agreement is signed, neither Party nor Party's principals (officers, directors, owners, or partners) are presently debarred, suspended, proposed for debarment, declared ineligible or excluded from participation in Federal programs, or programs supported in whole or in part by Federal funds.

Party further certifies under pains and penalties of perjury that, as of the date that this Agreement is signed, Party is not presently debarred, suspended, nor named on the State's debarment list at: <http://bgs.vermont.gov/purchasing/debarment>

9. State Facilities: If the State makes space available to the Party in any State facility during the term of this Agreement for purposes of the Party's performance under this Agreement, the Party shall only use the space in accordance with all policies and procedures governing access to and use of State facilities which shall be made available upon request. State facilities will be made available to Party on an "AS IS, WHERE IS" basis, with no warranties whatsoever.

10. Certification Regarding Use of State Funds: If Party is an employer and this Agreement is a State-funded grant in excess of \$1,001, Party certifies that none of these State funds will be used to interfere with or restrain the exercise of Party's employee's rights with respect to unionization.

(End of Standard Provisions)

Appendix G: Sample Data Collection Plan

Overview

The Vermont Department of Environmental Conservation (DEC) has launched an electric school and transit bus pilot program for the State of Vermont, funded by the Volkswagen Environmental Mitigation Trust (EMT). The pilot, administered by VEIC, will evaluate the feasibility and cost-effectiveness of electric school and transit bus operation in the state. To enable a thorough assessment of all aspects of electric bus deployment during this pilot, a variety of data will be required to track key metrics:

- Vehicle performance, including driver experiences operating the buses
- Operational costs, including maintenance, repair, and fuel costs
- Energy use
- Emissions reductions

To support this evaluation, each Project Partner will be expected to collect and report to VEIC information on their experiences deploying the electric buses. This Data Collection Plan details the specific data to be collected and methods by which data will be collected. The data will be collected for a full 12-month period of deployment. Data collection will be multi-faceted with parallel data collection methods employed to ensure continuity and completeness of data. When sufficient data has been collected, the most accurate, reliable, and efficient data will be prioritized for analysis; all data available will continue to be collected for the duration of the evaluation. After the initial 12-month deployment, partial data reporting to the State shall continue for as long as the buses are in use.

Data Ownership and Stewardship

Data collected will be turned over to the State of Vermont and may be subject to the State of Vermont Access to Public Records Act. Prior to and during the evaluation period, VEIC will aid in the set-up, collection, and maintenance of the data and any associated equipment necessary for the collection of that data.

Equipment installed at a site will be owned by the Project Partner upon the completion of installation on the condition that access to collected data will continue to be provided to the State or a designated third-party for the useful life of the buses. Upon the close of the 12-month evaluation period, the Project Partner will be responsible for maintenance and account management of the sub-metering hardware and any other data collection equipment. VEIC will provide the Project Partner with instructions and an overview of the user-interface to support maintenance and account management of sub-metering hardware or other data collection equipment.

During the evaluation period, remotely accessible data will be collected from various sources. With written permission granted, VEIC will collect advanced metering infrastructure (AMI) data from the Efficiency Vermont data warehouse. Electric vehicle supply equipment (EVSE) software and telematics data will be queried from the online dashboards provided by the vendors. Weather data will be collected from the National Oceanic and Atmospheric Administration (NOAA) resources targeted to the relevant geographic locations for each project partner.

All data provided to or collected by VEIC will be held on VEIC servers in a manner that prevents the co-mingling of this project's data with any other project data that VEIC may be holding. The pilot's data shall be backed up to a remote server at least nightly. VEIC shall maintain security on the data that is at a level at least equal to that of VEIC's own company data. All transference of data to the State or to/from the Project Partners shall be implemented via an encrypted drop-box. Directions for accessing and using this system shall be provided to the Project Partners and State of Vermont staff.

Data Collection

This Data Collection Plan details four primary approaches or manners through which Project Partners will collect and report data:

- Daily data collection through drivers' logs
- Periodic maintenance check-ins
- Automatic data collection for the initial 12 months
- Ongoing data collection for life of the vehicles

VEIC will work with Project Partners to identify staff responsible for data collection as well as provide training and oversight needed to ensure established protocols are being followed.

Data Collection Timeframes

With the first buses having been delivered at Franklin West Supervisory Union (FWSU) and Champlain Valley School District (CVSD) in the middle to end of August, data collection will begin with the school year for these project partners. For ease of reporting and allowing a few days to work out the bugs, the start date for data collection and report out for both schools is September 1, 2021. Pilot data will be collected at these sites through the end of August 2022.

Barre Unified Union School District (BUUSD), working with Student Transportation of America (STA), received their buses at the end of November 2021. After experiencing minor delays with getting their buses inspected and registered, we anticipate deployment will begin in January 2022 with full data collection for the period of February 2022 through January 2023.

Lastly, the Marble Valley Regional Transit District (MVRTD) received their two transit buses in January 2022. It is expected that their buses will be inspected and registered for deployment in

February, indicating that the 12-month deployment and data collection period will be for the period of February 2022 through January 2023.

Daily Data Collection: Drivers' Logs

For the duration of the 12-month deployment period, bus drivers will be required to complete a daily log. Certain datapoints such as road conditions, vehicle handling, or unusual route adjustments are best captured via human feedback and are critical to understanding how well suited these buses are for Vermont conditions. This data will be used strictly to aid in evaluating the buses and will allow for qualitative feedback to be consolidated into an anonymized format. The first-hand accounts from the bus drivers will NOT be used to identify drivers individually or to evaluate them in any way.

The logs will detail the following information:

- Odometer reading
- Routes driven¹
- State of charge at the beginning of day
- State of charge at the end of day
- Weather related road conditions
- Any issues/feedback about the bus
- Heater fuel - gallons filled

A template drivers' log is included as [Attachment 1](#). These logs are designed to be very similar to logs already in use at most facilities and may be incorporated into normal operations logs so as to simplify reporting for drivers and increase compliance with data gathering. The logs will be printed and kept on each bus with a clipboard and pen. The completed logs will be collected and transmitted (scanned and emailed, or entered into existing databases where available and accessed directly) at least monthly to VEIC.

Maintenance Logs

For the duration of the 12-month deployment period, Project Partners will also be required to keep their own maintenance logs to capture the following information:

- Maintenance required
- Labor hours spent on repairs
- Cost of repairs
- Duration of and reason for periods the buses are out of service

¹ Detailed route information will be obtained in advance, and the drivers' logs will simply identify which routes they drove. An option will be provided for reporting travel not on normal routes.

This information will be reported to VEIC during regular project check-ins. However, if a bus is taken out of service, that information must be reported to VEIC immediately.

Automatic Data Collection

For each EVSE installed, a true-power sub-meter will be installed on site to capture power usage. These sub-meters will be of utility-grade accuracy and will allow for both remote data access and viewing as well as local communication via BACNet, Modbus, or other commonly used communications protocol. Data viewing and export will be made available to Project Partners, though change-access will be restricted until the end of the evaluation period. Meters will be able to store a year's worth of data should communications go down, and all data will be backed up to VEIC servers weekly. Those VEIC servers, in-turn, are cached nightly to redundant fail-over servers located in separate facilities locally and nationally. Communications hardware will be deployed as needed to make site data remotely accessible, taking advantage of Project Partner networking wherever possible to enhance reliability. Cellular networking will be employed where hardline connections are not feasible.

The sub-meter mentioned above will verify the power draw and time of use for the charging equipment. All the selected bus manufacturers will also provide some level of telematics software onboard that allows for the capture and communication of parameters internal to the vehicle's systems, such as fault codes, mileage, state of charge, etc. Data collection options utilized will depend on the exact make and model of buses and EVSE selected by each Project Partner.

- At FWSU, the two Nuve Level 2 chargers selected are networked and power draw data will be referenced both as a redundant data source and the sub-meter data can be used to test the accuracy and reliability of such EVSE reported data. This will inform whether independent sub-metering is suggested for future installations or if EVSE-logged data alone is deemed adequate feedback for fleet managers. It is not expected that the other schools' EVSE will be able to provide the same informational output. The Blue Bird buses selected by FWSU will have telematics, but remote access is not yet available and Blue Bird access support is unlikely. VEIC will work with Blue Bird to try to gain access for period download and evaluation.
- At BUUSD, two ABB DC chargers were selected. These have some cellular network capabilities, but no useful data is likely to be accessible. The Lion Electric buses chosen come with telematics that provide daily summaries of miles traveled, state-of-charge, and kWh consumed. These data are directly available to VEIC at a daily frequency.
- Similarly, for CVSD, two ABB DC chargers were selected. These have some cellular network capabilities, but no useful data is likely to be accessible. The Lion Electric buses

chosen come with telematics that provide daily summaries of miles traveled, state-of-charge, and kWh consumed. These data are directly available to VEIC at a daily frequency.

- MVRTD's EVSE will include higher power ABB DC chargers, but it is unknown if any data from these will be directly available. However, a managed charging contractor, OpConnect, has been hired to help maintain, manage, and control these chargers. OpConnect's software comes with monitoring and logging features and VEIC will be granted access to these. Similar to FWSU, this data will be evaluated in comparison to the sub-meter and AMI data sources to validate its accuracy and future potential. Additionally, the OpConnect managed charging software will be reviewed and documented for fit, issues, and potential at other sites. MVRTD's Gillig transit buses come with full telematics that include data on all of the parameters mentioned above and more. Use of this data source will follow a similar course as that laid out above for the Lion buses.

A third automated data source that will be collected is from the electric utility. Fifteen-minute power data from the AMI will be gathered by leveraging VEIC's role as implementers of the Efficiency Vermont contract. Efficiency Vermont has an AMI data warehouse and toolset which will allow for very efficient capture and analysis of that data. Permission to access the data this way has been granted by the Project Partners and the Efficiency Vermont data steward via signed agreement, which includes permission to share this data with the Agency of Natural Resources at the close of the pilot project. At all sites, utility AMI data will be referenced as a check on the sub-metering data.

Data automatically collected from meters and third-party platforms (i.e. National Oceanic and Atmospheric Administration, Efficiency Vermont, and where possible the EVSE and/or bus telematics) will include:

- Daily kWh used
- Max power draw and load-profile
- Times and duration that vehicle is charging from charging station
- Ambient weather conditions
- Additional telematics parameters where available

NOAA data will be taken from 15-minute interval datasets curated by VEIC for those stations geographically closest to the project partner sites. MVRTD's data will come from the Rutland Southern Vermont Regional Airport (RUT); FWSU's data from the Franklin County State Airport (KFSO); CVSD's weather data will come from Burlington International Airport (BTV); and BUUSD's data from the Edward F. Knapp State Airport (KMPV).

Ongoing Data Collection

After the initial 12-month deployment, Project Partners will be required to continue partial data reporting to the State for as long as the buses are in use. Data collection will be primarily focused on records keeping by the Project Partner that would typically be a part of their regular operations and tracking. Project Partners will be required to track and report the following data annually:

- Odometer reading
- Capacity of battery
- Specific repairs needed in the last year
- Total cost for maintenance and repairs incurred in the last year
- Notification of any major damages or loss

Annually, on a date determined at the completion of the initial 12-month deployment, Project Partners will submit this information to:

Leigh Martin
Department of Environmental Conservation
Vermont Agency of Natural Resources

Additionally, Project Partners will be required to maintain network access to the EVSE and/or sub-meter data such that the automatic data collection described above continues for as long as the buses are in use.

Reporting

Using the primary data described above, VEIC will provide the methodology used and apply engineering calculations along with nationally recognized emissions calculation tools to report the following metrics to the State monthly and in summary at the end of the pilot for each bus deployed for the duration of the 12-month deployment period:

- NOx reductions
- GHG reductions
- PM reductions
- Average daily mileage for days the bus is in service
- Effective average range
- Daily average kWh used
- Vehicle efficiency (miles/kWh)
- Estimated charging/fuel cost
- Auxiliary heater fuel use
- Estimated fossil fuel savings - volume

- Estimated fossil fuel savings - cost
- Average charging load profile
- Actual charging schedules
- Assessment of 'vampire' loads
- Maintenance costs
- Number of days vehicles are in (and out of) service

Project Partners will **not** be required to support the analysis or reporting of these metrics.

Attachment 1: Drivers' Log Template

School District Name

Bus # **XX**

Driver's Log

Route "A": <i>Route Description</i>	Route "B": <i>Route Description</i>	Route "C": <i>Route Description</i>	Route "O": <i>Other (enter in notes field)</i>
-------------------------------------	-------------------------------------	-------------------------------------	--

	<u>Date</u>	<u>Time</u>	<u>Odometer</u>	<u>% Battery</u>	<u>Heater Fuel (gals.)</u>	<u>Driver Initials</u>	<u>Route (see above)</u>	<u>Road Conditions</u>	<u>Issue/Observations/Notes</u>
<u>Depart</u>								<input type="checkbox"/> Wet <input type="checkbox"/> Mud <input type="checkbox"/> Slush <input type="checkbox"/> Snow	
<u>Return</u>								<input type="checkbox"/> Ice <input type="checkbox"/> Dry	
<u>Depart</u>								<input type="checkbox"/> Wet <input type="checkbox"/> Mud <input type="checkbox"/> Slush <input type="checkbox"/> Snow	
<u>Return</u>								<input type="checkbox"/> Ice <input type="checkbox"/> Dry	
<u>Depart</u>								<input type="checkbox"/> Wet <input type="checkbox"/> Mud <input type="checkbox"/> Slush <input type="checkbox"/> Snow	
<u>Return</u>								<input type="checkbox"/> Ice <input type="checkbox"/> Dry	
<u>Depart</u>								<input type="checkbox"/> Wet <input type="checkbox"/> Mud <input type="checkbox"/> Slush <input type="checkbox"/> Snow	
<u>Return</u>								<input type="checkbox"/> Ice <input type="checkbox"/> Dry	
<u>Depart</u>								<input type="checkbox"/> Wet <input type="checkbox"/> Mud <input type="checkbox"/> Slush <input type="checkbox"/> Snow	
<u>Return</u>								<input type="checkbox"/> Ice <input type="checkbox"/> Dry	
<u>Depart</u>								<input type="checkbox"/> Wet <input type="checkbox"/> Mud <input type="checkbox"/> Slush <input type="checkbox"/> Snow	
<u>Return</u>								<input type="checkbox"/> Ice <input type="checkbox"/> Dry	
<u>Depart</u>								<input type="checkbox"/> Wet <input type="checkbox"/> Mud <input type="checkbox"/> Slush <input type="checkbox"/> Snow	
<u>Return</u>								<input type="checkbox"/> Ice <input type="checkbox"/> Dry	
<u>Depart</u>								<input type="checkbox"/> Wet <input type="checkbox"/> Mud <input type="checkbox"/> Slush <input type="checkbox"/> Snow	
<u>Return</u>								<input type="checkbox"/> Ice <input type="checkbox"/> Dry	
<u>Depart</u>								<input type="checkbox"/> Wet <input type="checkbox"/> Mud <input type="checkbox"/> Slush <input type="checkbox"/> Snow	
<u>Return</u>								<input type="checkbox"/> Ice <input type="checkbox"/> Dry	
<u>Depart</u>								<input type="checkbox"/> Wet <input type="checkbox"/> Mud <input type="checkbox"/> Slush <input type="checkbox"/> Snow	
<u>Return</u>								<input type="checkbox"/> Ice <input type="checkbox"/> Dry	

Appendix H: Summary of Media Reports

A press release announcing the project was posted to VEIC and DEC's websites on June 12, 2019. The press release was picked up by:

- [School Transportation News on June 12](#), 2019.
- [School Bus Fleet on June 17](#), 2019.
- [VT Digger on June 20](#), 2019.

An RFQ was released on the [Vermont Business Registry](#) on July 5, 2019.

WPTZ included Jennifer Wallace-Brodeur and Emily Boedecker in a [story](#) about how Vermont is impacted by large lawsuit settlements on July 25, 2019.

An FAQ was completed and posted to both [ANR's VW EMT site](#) as well as to the [Vermont Business Registry](#) in July 2019.

The Essex Reporter featured a [story](#) highlighting the VT Electric Bus Pilot Program on September 26, 2019. The RFP was completed and posted to both [ANR's VW EMT site](#) as well as to the [Vermont Business Registry](#).

VEIC and DEC were interviewed by the [Energy News Network for an article](#) published on November 15, 2019.

The press event announcing the Project Partners held on December 19, 2019, received coverage including:

- [Eagle Times](#) on December 19, 2019
- [Barre Montpelier Times Argus](#) on December 19, 2019
- [My Champlain Valley](#) on December 19, 2019
- [Rutland Herald](#) on December 19, 2019
- [Champlain Valley School District](#) on December 20, 2019
- [Associated Press](#) on December 23, 2019
- [Saint Albans Messenger](#) on December 23, 2019
- [Shelburne News](#) on December 26, 2019

On January 27, 2020, [WCAX ran a story](#) on Vermont testing electric transit buses to reduce our carbon footprint. Marble Valley Regional Transit District was featured and Ken Putnam, ED at MVRTD, and Devon Neary, transportation planner for the Rutland Regional Planning Commission, were both featured discussing their involvement in the VW eBus Pilot.

In late January 2020, Don Keelan wrote an op-ed that was picked up by [True North Reports](#) and [Bennington Banner](#). On February 4, [VT Digger](#) also picked up the story which prompted a discussion between VEIC and ANR on whether or not to comment and correct the inaccuracies presented. ANR decided to not respond as to not give the story any more traction.

FWSU posted a [blog update](#) on January 4, 2021, highlighting the recent EVSE installation work and project progress.

VEIC coordinated with ANR to issue a [press release](#) on January 28, 2021, announcing the vendors that had been selected by the Project Partners. The release was picked up by: [Mountain Times](#); [VTDigger](#); and [Vermont Business Magazine](#).

In August, 2021, CVSD did a small amount of media outreach when their buses were delivered, which resulted in this [story](#) posted on August 26. CVSD also shared a [blog post](#) for their internal newsletter.

In October 2021, there was significant media coverage of the bus event in Fairfax:

- The World: [Vermont Students Head Back to School on Electric Buses](#)
- VTDigger.org: [Electric school buses roll out in pilot project in three Vermont districts](#)
- WVNY-TV (Colchester, VT): [Three Vermont school districts now rolling with electric bus pilot program](#)
- Times Argus: [Vermont pilot program tests electric school buses](#)
- WPTZ-TV (South Burlington, VT): [Vermont introduces all-electric buses as part of pilot program](#)
- WCAX-TV (Burlington, VT): [Electric school buses to hit the road in Vt. districts](#)
- St. Albans Daily Messenger: [This electric bus will transport BFA-Fairfax kids to school](#)
- Vermont Business Magazine: [Vermont students head back to school on electric buses](#)

In April 2022, a press release was issued by the Governor's office on April 18, 2022, and several news media outlets picked the story up:

- The Office of Governor Phil Scott (Montpelier, VT): [Volkswagen Environmental Trust Fund Delivers Rutland County Two New Electric Transit Buses](#)
- Mountain Times (Killington, VT): [Rutland County's MVRTD gets two electric buses](#)
- Vermont Business Magazine: [Rutland County gets two electric transit buses via the VW Environmental Mitigation Trust Fund](#)
- The Center Square: [Vermont public transportation receives pair of electric buses](#)
- WCAX: [Marble Valley Regional Transit District puts 2 electric buses on the road](#)

In September 2022, WCAX covered the VW eBus Pilot buses at CVSD as well as South Burlington's new buses. In broadcast, they interview the two fleet coordinators, as well as GMP and the Agency of Natural Resources: WCAX-TV (Burlington, VT): [**Some Vermont schools roll out electric school buses.**](#)